

SN54LVT16501, SN74LVT16501 3.3-V ABT 18-BIT UNIVERSAL BUS TRANSCEIVERS WITH 3-STATE OUTPUTS

SCBS147G – MAY 1992 – REVISED NOVEMBER 1996

- State-of-the-Art Advanced BiCMOS Technology (ABT) Design for 3.3-V Operation and Low-Static Power Dissipation
- Members of the Texas Instruments *Widebus™* Family
- Support Mixed-Mode Signal Operation (5-V Input and Output Voltages With 3.3-V V_{CC})
- Support Unregulated Battery Operation Down to 2.7 V
- *UBT™* (Universal Bus Transceiver) Combines D-Type Latches and D-Type Flip-Flops for Operation in Transparent, Latched, or Clocked Mode
- Typical V_{OLP} (Output Ground Bounce) < 0.8 V at $V_{CC} = 3.3$ V, $T_A = 25^\circ\text{C}$
- ESD Protection Exceeds 2000 V Per MIL-STD-883, Method 3015; Exceeds 200 V Using Machine Model ($C = 200$ pF, $R = 0$)
- Latch-Up Performance Exceeds 500 mA Per JEDEC Standard JESD-17
- Bus Hold on Data Inputs Eliminates the Need for External Pullup/Pulldown Resistors
- Support Live Insertion
- Distributed V_{CC} and GND Pin Configuration Minimizes High-Speed Switching Noise
- Flow-Through Architecture Optimizes PCB Layout
- Package Options Include Plastic 300-mil Shrink Small-Outline (DL) and Thin Shrink Small-Outline (DGG) Packages and 380-mil Fine-Pitch Ceramic Flat (WD) Package Using 25-mil Center-to-Center Spacings

SN54LVT16501 . . . WD PACKAGE
SN74LVT16501 . . . DGG OR DL PACKAGE
(TOP VIEW)

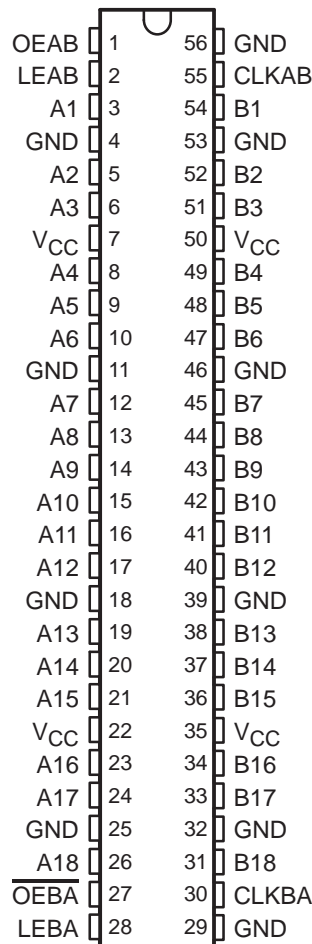

description

The 'LVT16501 are 18-bit universal bus transceivers designed for low-voltage (3.3-V) V_{CC} operation, but with the capability to provide a TTL interface to a 5-V system environment.

Data flow in each direction is controlled by output-enable (OEAB and \overline{OEBA}), latch-enable (LEAB and LEBA), and clock (CLKAB and CLKBA) inputs. For A-to-B data flow, the devices operate in the transparent mode when LEAB is high. When LEAB is low, the A data is latched if CLKAB is held at a high or low logic level. If LEAB is low, the A-bus data is stored in the latch/flip-flop on the low-to-high transition of CLKAB. When OEAB is high, the outputs are active. When OEAB is low, the outputs are in the high-impedance state.



Please be aware that an important notice concerning availability, standard warranty, and use in critical applications of Texas Instruments semiconductor products and disclaimers thereto appears at the end of this data sheet.

Widebus and UBT are trademarks of Texas Instruments Incorporated.

PRODUCTION DATA information is current as of publication date. Products conform to specifications per the terms of Texas Instruments standard warranty. Production processing does not necessarily include testing of all parameters.

 **TEXAS
INSTRUMENTS**

POST OFFICE BOX 655303 • DALLAS, TEXAS 75265

Copyright © 1996, Texas Instruments Incorporated

SN54LVT16501, SN74LVT16501

3.3-V ABT 18-BIT UNIVERSAL BUS TRANSCEIVERS

WITH 3-STATE OUTPUTS

SCBS147G – MAY 1992 – REVISED NOVEMBER 1996

description (continued)

Data flow for B to A is similar to that of A to B but uses \overline{OEBA} , LEBA, and CLKBA. The output enables are complementary (OEAB is active high and \overline{OEBA} is active low).

Active bus-hold circuitry is provided to hold unused or floating data inputs at a valid logic level.

To ensure the high-impedance state during power up or power down, \overline{OE} should be tied to V_{CC} through a pullup resistor. The minimum value of the resistor is determined by the current-sinking capability of the driver. OE should be tied to GND through a pulldown resistor; the minimum value of the resistor is determined by the current-sourcing capability of the driver.

The SN74LVT16501 is available in TI's shrink small-outline (DL) and thin shrink small-outline (DGG) packages, which provide twice the input/output (I/O) pin count and functionality of standard small-outline packages in the same printed circuit board area.

The SN54LVT16501 is characterized for operation over the full military temperature range of -55°C to 125°C . The SN74LVT16501 is characterized for operation from -40°C to 85°C .

FUNCTION TABLE†

INPUTS				OUTPUT
OEAB	LEAB	CLKAB	A	B
L	X	X	X	Z
H	H	X	L	L
H	H	X	H	H
H	L	↑	L	L
H	L	↑	H	H
H	L	H	X	B_0^{\ddagger}
H	L	L	X	B_0^{\S}

† A-to-B data flow is shown; B-to-A flow is similar but uses \overline{OEBA} , LEBA, and CLKBA.

‡ Output level before the indicated steady-state input conditions were established, provided that CLKAB was high before LEAB went low

§ Output level before the indicated steady-state input conditions were established



SN54LVT16501, SN74LVT16501 3.3-V ABT 18-BIT UNIVERSAL BUS TRANSCEIVERS WITH 3-STATE OUTPUTS

SCBS147G – MAY 1992 – REVISED NOVEMBER 1996

logic symbol†

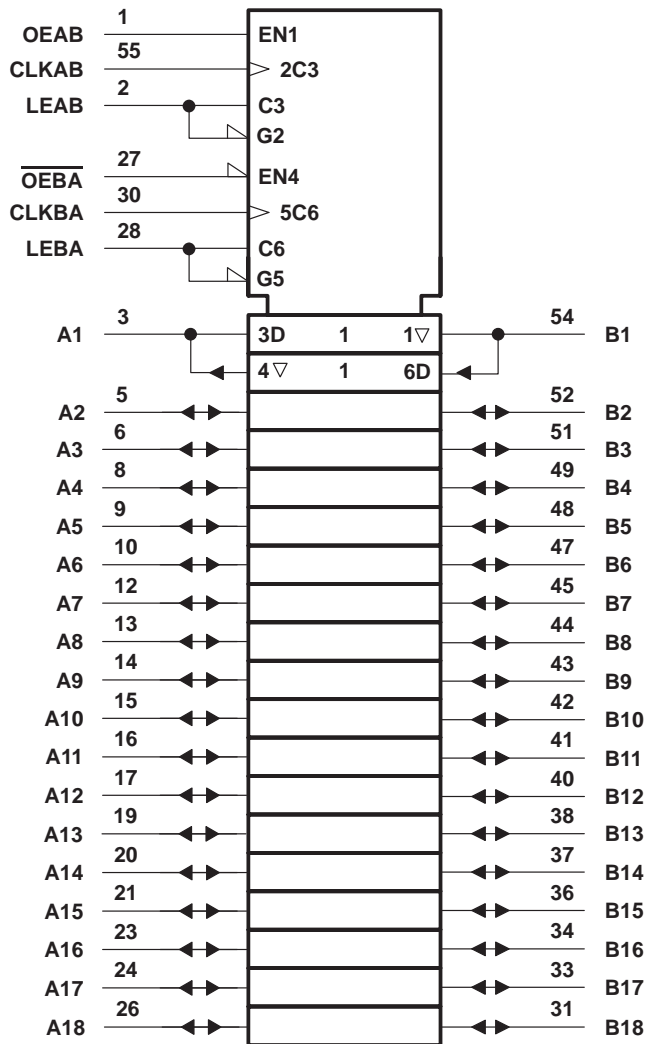

† This symbol is in accordance with ANSI/IEEE Std 91-1984 and IEC Publication 617-12.

SN54LVT16501, SN74LVT16501 3.3-V ABT 18-BIT UNIVERSAL BUS TRANSCEIVERS WITH 3-STATE OUTPUTS

SCBS147G – MAY 1992 – REVISED NOVEMBER 1996

logic diagram (positive logic)

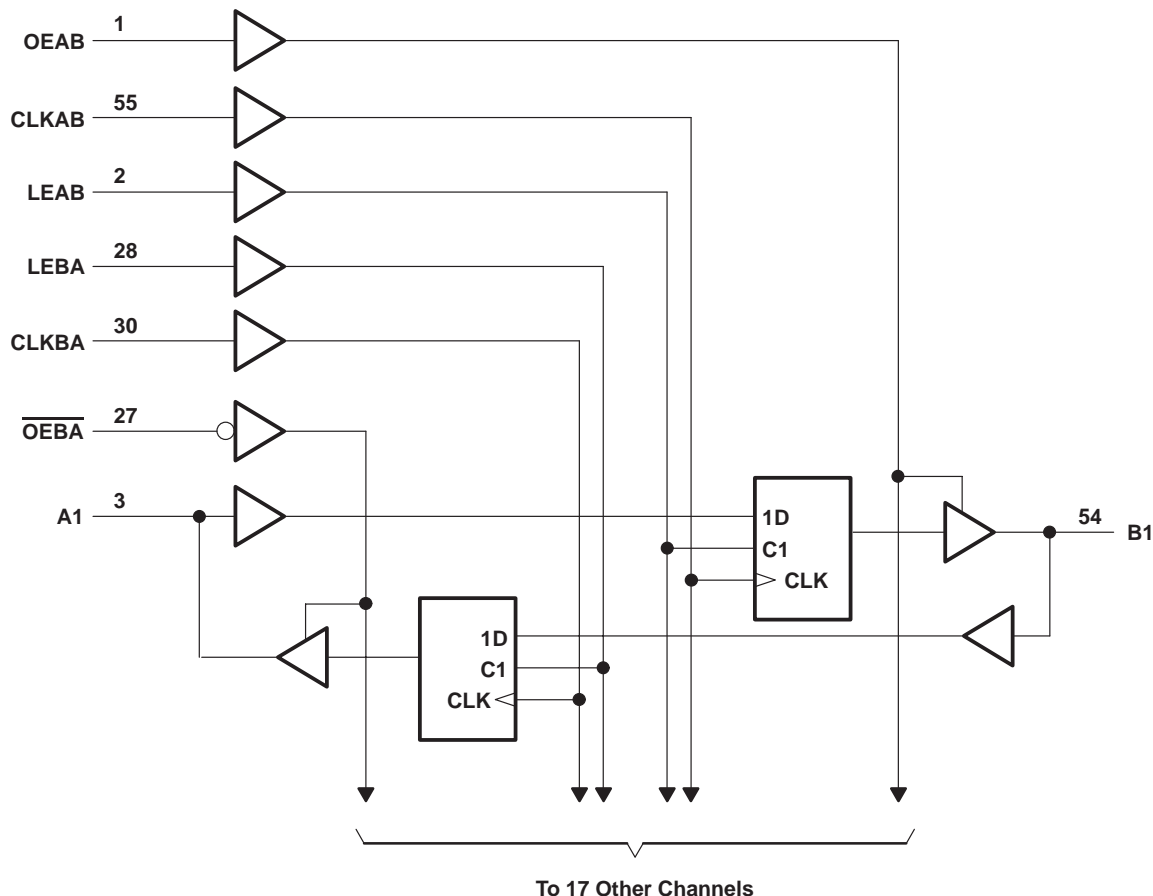

absolute maximum ratings over operating free-air temperature range (unless otherwise noted)[†]

Supply voltage range, V_{CC}	-0.5 V to 4.6 V
Input voltage range, V_I (see Note 1)	-0.5 V to 7 V
Voltage range applied to any output in the high state or power-off state, V_O (see Note 1)	-0.5 V to 7 V
Current into any output in the low state, I_O : SN54LVT16501	96 mA
SN74LVT16501	128 mA
Current into any output in the high state, I_O (see Note 2): SN54LVT16501	48 mA
SN74LVT16501	64 mA
Input clamp current, I_{IK} ($V_I < 0$)	-50 mA
Output clamp current, I_{OK} ($V_O < 0$)	-50 mA
Maximum power dissipation at $T_A = 55^\circ\text{C}$ (in still air) (see Note 3): DGG package	1 W
DL package	1.4 W
Storage temperature range, T_{stg}	-65°C to 150°C

[†] Stresses beyond those listed under "absolute maximum ratings" may cause permanent damage to the device. These are stress ratings only, and functional operation of the device at these or any other conditions beyond those indicated under "recommended operating conditions" is not implied. Exposure to absolute-maximum-rated conditions for extended periods may affect device reliability.

- NOTES: 1. The input and output negative-voltage ratings may be exceeded if the input and output clamp-current ratings are observed.
 2. This current flows only when the output is in the high state and $V_O > V_{CC}$.
 3. The maximum package power dissipation is calculated using a junction temperature of 150°C and a board trace length of 750 mils. For more information, refer to the *Package Thermal Considerations* application note in the *ABT Advanced BiCMOS Technology Data Book*.



SN54LVT16501, SN74LVT16501
3.3-V ABT 18-BIT UNIVERSAL BUS TRANSCEIVERS
WITH 3-STATE OUTPUTS

SCBS147G – MAY 1992 – REVISED NOVEMBER 1996

recommended operating conditions (see Note 4)

		SN54LVT16501		SN74LVT16501		UNIT
		MIN	MAX	MIN	MAX	
V_{CC}	Supply voltage	2.7	3.6	2.7	3.6	V
V_{IH}	High-level input voltage	2		2		V
V_{IL}	Low-level input voltage		0.8		0.8	V
V_I	Input voltage		5.5		5.5	V
I_{OH}	High-level output current		-24		-32	mA
I_{OL}	Low-level output current		48		64	mA
$\Delta t/\Delta v$	Input transition rise or fall rate	Outputs enabled		10	10	ns/V
T_A	Operating free-air temperature	-55	125	-40	85	°C

NOTE 4: Unused control inputs must be held high or low to prevent them from floating.

SN54LVT16501, SN74LVT16501
3.3-V ABT 18-BIT UNIVERSAL BUS TRANSCEIVERS
WITH 3-STATE OUTPUTS

SCBS147G – MAY 1992 – REVISED NOVEMBER 1996

electrical characteristics over recommended operating free-air temperature range (unless otherwise noted)

PARAMETER		TEST CONDITIONS		SN54LVT16501			SN74LVT16501			UNIT	
				MIN	TYP†	MAX	MIN	TYP†	MAX		
V _{IK}		V _{CC} = 2.7 V, I _I = -18 mA		-1.2			-1.2			V	
V _{OH}		V _{CC} = 2.7 V to 3.6 V, I _{OH} = -100 μA		V _{CC} -0.2			V _{CC} -0.2			V	
		V _{CC} = 2.7 V, I _{OH} = -8 mA		2.4			2.4				
		V _{CC} = 3 V		I _{OH} = -24 mA			2				
				I _{OH} = -32 mA			2				
V _{OL}		V _{CC} = 2.7 V		I _{OL} = 100 μA		0.2			0.2		
				I _{OL} = 24 mA		0.5			0.5		
		V _{CC} = 3 V		I _{OL} = 16 mA		0.4			0.4		
				I _{OL} = 32 mA		0.5			0.5		
				I _{OL} = 48 mA		0.55					
				I _{OL} = 64 mA					0.55		
I _I		Control pins		V _{CC} = 3.6 V, V _I = V _{CC} or GND		±1			±1		
				V _{CC} = 0 or 3.6 V, V _I = 5.5 V		10			10		
A or B ports‡		V _{CC} = 3.6 V		V _I = 5.5 V		120			20		
				V _I = V _{CC}		1			1		
				V _I = 0		-5			-5		
I _{off}		V _{CC} = 0, V _I or V _O = 0 to 4.5 V					±100			μA	
I _I (hold)		A or B ports		V _{CC} = 3 V, V _I = 0.8 V		75			75		
				V _I = 2 V		-75			-75		
I _{OZH}		V _{CC} = 3.6 V, V _O = 3 V					1			μA	
I _{OZL}		V _{CC} = 3.6 V, V _O = 0.5 V					-1			μA	
I _{CC}		V _{CC} = 3.6 V, V _I = V _{CC} or GND, I _O = 0,		Outputs high		0.12			0.12		
				Outputs low		5			5		
				Outputs disabled		0.12			0.12		
ΔI _{CC} §		V _{CC} = 3 V to 3.6 V, One input at V _{CC} - 0.6 V, Other inputs at V _{CC} or GND		0.2			0.2			mA	
C _i		V _I = 3 V or 0		3.5			3.5			pF	
C _{io}		V _O = 3 V or 0		12			12			pF	

† All typical values are at V_{CC} = 3.3 V, T_A = 25°C.

‡ Unused pins at V_{CC} or GND

§ This is the increase in supply current for each input that is at the specified TTL voltage level rather than V_{CC} or GND.



SN54LVT16501, SN74LVT16501
3.3-V ABT 18-BIT UNIVERSAL BUS TRANSCEIVERS
WITH 3-STATE OUTPUTS

SCBS147G – MAY 1992 – REVISED NOVEMBER 1996

timing requirements over recommended operating free-air temperature range (unless otherwise noted) (see Figure 1)

		SN54LVT16501				SN74LVT16501				UNIT
		$V_{CC} = 3.3\text{ V} \pm 0.3\text{ V}$		$V_{CC} = 2.7\text{ V}$		$V_{CC} = 3.3\text{ V} \pm 0.3\text{ V}$		$V_{CC} = 2.7\text{ V}$		
		MIN	MAX	MIN	MAX	MIN	MAX	MIN	MAX	
f_{clock}	Clock frequency	0	150	0	125	0	150	0	125	MHz
t_w	Pulse duration	LE high	3.3	3.3	3.3	3.3	3.3	3.3	3.3	ns
		CLK high or low	3.3	3.3	3.3	3.3	3.3	3.3	3.3	
t_{su}	Setup time	A before CLKAB \uparrow	1.6	2.1	1.6	2.1	1.6	2.1	1.6	ns
		B before CLKBA \uparrow	1.6	2.1	1.6	2.1	1.6	2.1	1.6	
		A or B before LE \downarrow , $\overline{\text{CLK}}$ high	3.1	2.7	2.6	1.9	2.6	1.9	2.6	
		A or B before LE \downarrow , $\overline{\text{CLK}}$ low	2.6	2.0	2	1.3	2.6	1.9	2.6	
t_h	Hold time	A or B after CLK \uparrow	2	2.1	2	2.1	2	2.1	2	ns
		A or B after LE \downarrow	1.3	1.2	0.9	1.2	1.3	1.2	1.3	

switching characteristics over recommended operating free-air temperature range, $C_L = 50\text{ pF}$ (unless otherwise noted) (see Figure 1)

PARAMETER	FROM (INPUT)	TO (OUTPUT)	SN54LVT16501				SN74LVT16501				UNIT	
			$V_{CC} = 3.3\text{ V} \pm 0.3\text{ V}$		$V_{CC} = 2.7\text{ V}$		$V_{CC} = 3.3\text{ V} \pm 0.3\text{ V}$			$V_{CC} = 2.7\text{ V}$		
			MIN	MAX	MIN	MAX	MIN	TYP \dagger	MAX	MIN		MAX
f_{max}			150		125			150		125	MHz	
t_{PLH}	B or A	A or B	1.7	5.4		6.8	1.7	3	5.4		6.8	ns
t_{PHL}			1.6	6		7.8	1.6	3.2	5.9		7.7	
t_{PLH}	LEBA or LEAB	A or B	2.3	7.3		9	2.3	4	7		8.5	ns
t_{PHL}			2.7	8.2		9.8	2.7	4.3	7.9		9.7	
t_{PLH}	CLKBA or CLKAB	A or B	2.5	8.3		9.7	2.5	4.1	7.9		9.2	ns
t_{PHL}			3.5	9.4		10.7	3.5	5.4	8.9		10.4	
t_{PZH}	$\overline{\text{OEBA}}$ or OEAB	A or B	1.2	5.1		6.1	1.2	3	5		5.9	ns
t_{PZL}			1.5	5.9		7	1.5	3	5.8		6.9	
t_{PHZ}	$\overline{\text{OEBA}}$ or OEAB	A or B	2.7	7.5		8.5	2.7	4.6	7.4		8.3	ns
t_{PLZ}			2.8	6.8		7.5	2.8	4.7	6.7		7.2	

\dagger All typical values are at $V_{CC} = 3.3\text{ V}$, $T_A = 25^\circ\text{C}$.

SN54LVT16501, SN74LVT16501 3.3-V ABT 18-BIT UNIVERSAL BUS TRANSCEIVERS WITH 3-STATE OUTPUTS

SCBS147G – MAY 1992 – REVISED NOVEMBER 1996

PARAMETER MEASUREMENT INFORMATION

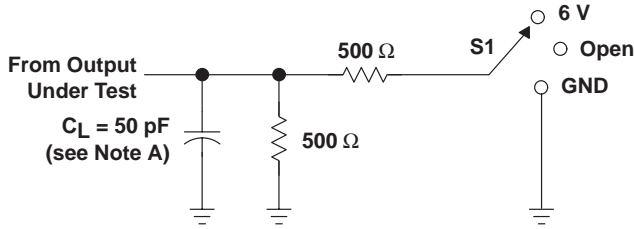

LOAD CIRCUIT

TEST	S1
t_{PLH}/t_{PHL}	Open
t_{PLZ}/t_{PZL}	6 V
t_{PHZ}/t_{PZH}	GND

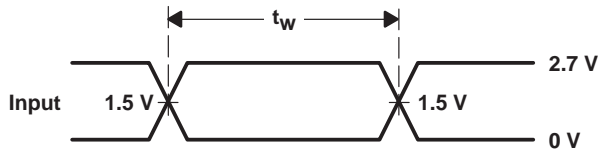

VOLTAGE WAVEFORMS
PULSE DURATION

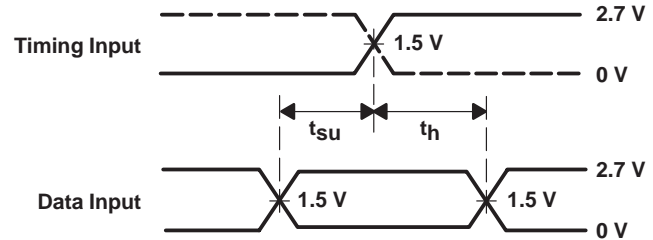

VOLTAGE WAVEFORMS
SETUP AND HOLD TIMES

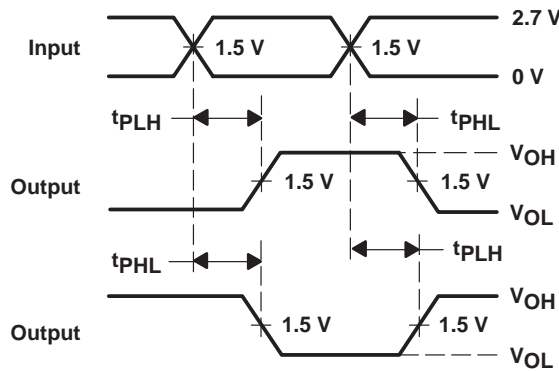

VOLTAGE WAVEFORMS
PROPAGATION DELAY TIMES
INVERTING AND NONINVERTING OUTPUTS

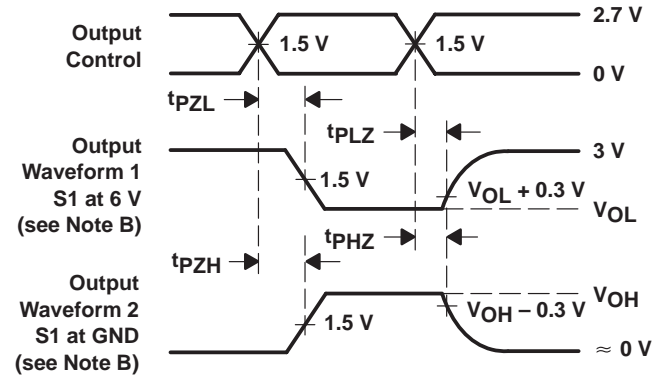

VOLTAGE WAVEFORMS
ENABLE AND DISABLE TIMES
LOW- AND HIGH-LEVEL ENABLING

- NOTES:
- C_L includes probe and jig capacitance.
 - Waveform 1 is for an output with internal conditions such that the output is low except when disabled by the output control. Waveform 2 is for an output with internal conditions such that the output is high except when disabled by the output control.
 - All input pulses are supplied by generators having the following characteristics: $PRR \leq 10 \text{ MHz}$, $Z_O = 50 \Omega$, $t_r \leq 2.5 \text{ ns}$, $t_f \leq 2.5 \text{ ns}$.
 - The outputs are measured one at a time with one transition per measurement.

Figure 1. Load Circuit and Voltage Waveforms

IMPORTANT NOTICE

Texas Instruments and its subsidiaries (TI) reserve the right to make changes to their products or to discontinue any product or service without notice, and advise customers to obtain the latest version of relevant information to verify, before placing orders, that information being relied on is current and complete. All products are sold subject to the terms and conditions of sale supplied at the time of order acknowledgement, including those pertaining to warranty, patent infringement, and limitation of liability.

TI warrants performance of its semiconductor products to the specifications applicable at the time of sale in accordance with TI's standard warranty. Testing and other quality control techniques are utilized to the extent TI deems necessary to support this warranty. Specific testing of all parameters of each device is not necessarily performed, except those mandated by government requirements.

CERTAIN APPLICATIONS USING SEMICONDUCTOR PRODUCTS MAY INVOLVE POTENTIAL RISKS OF DEATH, PERSONAL INJURY, OR SEVERE PROPERTY OR ENVIRONMENTAL DAMAGE ("CRITICAL APPLICATIONS"). TI SEMICONDUCTOR PRODUCTS ARE NOT DESIGNED, AUTHORIZED, OR WARRANTED TO BE SUITABLE FOR USE IN LIFE-SUPPORT DEVICES OR SYSTEMS OR OTHER CRITICAL APPLICATIONS. INCLUSION OF TI PRODUCTS IN SUCH APPLICATIONS IS UNDERSTOOD TO BE FULLY AT THE CUSTOMER'S RISK.

In order to minimize risks associated with the customer's applications, adequate design and operating safeguards must be provided by the customer to minimize inherent or procedural hazards.

TI assumes no liability for applications assistance or customer product design. TI does not warrant or represent that any license, either express or implied, is granted under any patent right, copyright, mask work right, or other intellectual property right of TI covering or relating to any combination, machine, or process in which such semiconductor products or services might be or are used. TI's publication of information regarding any third party's products or services does not constitute TI's approval, warranty or endorsement thereof.