

SN74LVCH32373A

32-BIT TRANSPARENT D-TYPE LATCH WITH 3-STATE OUTPUTS

SCAS618D – OCTOBER 1998 – REVISED AUGUST 2003

- Member of the Texas Instruments Widebus+™ Family
- Operates From 1.65 V to 3.6 V
- Inputs Accept Voltages to 5.5 V
- Max t_{pd} of 4.2 ns at 3.3 V
- Typical V_{OLP} (Output Ground Bounce) <0.8 V at $V_{CC} = 3.3$ V, $T_A = 25^\circ\text{C}$
- Typical V_{OHV} (Output V_{OH} Undershoot) >2 V at $V_{CC} = 3.3$ V, $T_A = 25^\circ\text{C}$
- I_{off} Supports Partial-Power-Down Mode Operation
- Supports Mixed-Mode Signal Operation (5-V Input and Output Voltages With 3.3-V V_{CC})
- Bus Hold on Data Inputs Eliminates the Need for External Pullup/Pulldown Resistors
- Latch-Up Performance Exceeds 250 mA Per JESD 17
- ESD Protection Exceeds JESD 22
 - 2000-V Human-Body Model (A114-A)
 - 200-V Machine Model (A115-A)

description/ordering information

This 32-bit transparent D-type latch is designed for 1.65-V to 3.6-V V_{CC} operation.

The SN74LVCH32373A is particularly suitable for implementing buffer registers, I/O ports, bidirectional bus drivers, and working registers. It can be used as four 8-bit latches, two 16-bit latches, or one 32-bit latch. When the latch-enable (LE) input is high, the Q outputs follow the data (D) inputs. When LE is taken low, the Q outputs are latched at the levels set up at the D inputs.

A buffered output-enable (\overline{OE}) input can be used to place the eight outputs in either a normal logic state (high or low logic levels) or the high-impedance state. In the high-impedance state, the outputs neither load nor drive the bus lines significantly. The high-impedance state and increased drive provide the capability to drive bus lines without interface or pullup components.

\overline{OE} does not affect internal operations of the latch. Old data can be retained or new data can be entered while the outputs are in the high-impedance state.

Inputs can be driven from either 3.3-V or 5-V devices. This feature allows the use of these devices as translators in a mixed 3.3-V/5-V system environment.

This device is fully specified for partial-power-down applications using I_{off} . The I_{off} circuitry disables the outputs, preventing damaging current backflow through the device when it is powered down.

To ensure the high-impedance state during power up or power down, \overline{OE} should be tied to V_{CC} through a pullup resistor; the minimum value of the resistor is determined by the current-sinking capability of the driver.

Active bus-hold circuitry holds unused or undriven inputs at a valid logic state. Use of pullup or pulldown resistors with the bus-hold circuitry is not recommended.

ORDERING INFORMATION

T _A	PACKAGE†	ORDERABLE PART NUMBER	TOP-SIDE MARKING
–40°C to 85°C	LFPGA – GKE Tape and reel	SN74LVCH32373AGKER	CH373A

† Package drawings, standard packing quantities, thermal data, symbolization, and PCB design guidelines are available at www.ti.com/sc/package.



Please be aware that an important notice concerning availability, standard warranty, and use in critical applications of Texas Instruments semiconductor products and disclaimers thereto appears at the end of this data sheet.

Widebus+ is a trademark of Texas Instruments.

PRODUCTION DATA information is current as of publication date. Products conform to specifications per the terms of Texas Instruments standard warranty. Production processing does not necessarily include testing of all parameters.



POST OFFICE BOX 655303 • DALLAS, TEXAS 75265

Copyright © 2003, Texas Instruments Incorporated

SN74LVCH32373A

32-BIT TRANSPARENT D-TYPE LATCH

WITH 3-STATE OUTPUTS

SCAS618D – OCTOBER 1998 – REVISED AUGUST 2003

GKE PACKAGE
(TOP VIEW)

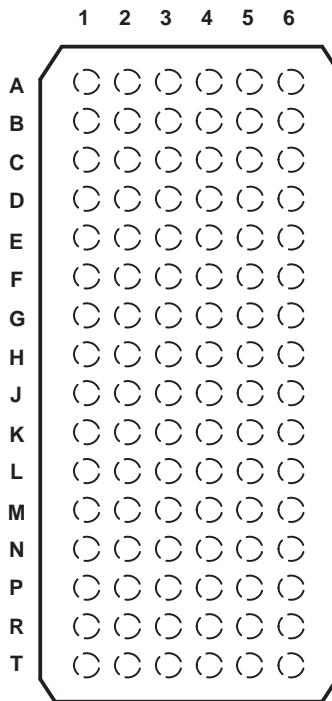

terminal assignments

	1	2	3	4	5	6
A	1Q2	1Q1	$\overline{1OE}$	1LE	1D1	1D2
B	1Q4	1Q3	GND	GND	1D3	1D4
C	1Q6	1Q5	V _{CC}	V _{CC}	1D5	1D6
D	1Q8	1Q7	GND	GND	1D7	1D8
E	2Q2	2Q1	GND	GND	2D1	2D2
F	2Q4	2Q3	V _{CC}	V _{CC}	2D3	2D4
G	2Q6	2Q5	GND	GND	2D5	2D6
H	2Q7	2Q8	$\overline{2OE}$	2LE	2D8	2D7
J	3Q2	3Q1	$\overline{3OE}$	3LE	3D1	3D2
K	3Q4	3Q3	GND	GND	3D3	3D4
L	3Q6	3Q5	V _{CC}	V _{CC}	3D5	3D6
M	3Q8	3Q7	GND	GND	3D7	3D8
N	4Q2	4Q1	GND	GND	4D1	4D2
P	4Q4	4Q3	V _{CC}	V _{CC}	4D3	4D4
R	4Q6	4Q5	GND	GND	4D5	4D6
T	4Q7	4Q8	$\overline{4OE}$	4LE	4D8	4D7

FUNCTION TABLE

INPUTS			OUTPUT Q
\overline{OE}	LE	D	
L	H	H	H
L	H	L	L
L	L	X	Q ₀
H	X	X	Z

SN74LVCH32373A 32-BIT TRANSPARENT D-TYPE LATCH WITH 3-STATE OUTPUTS

SCAS618D – OCTOBER 1998 – REVISED AUGUST 2003

logic diagram (positive logic)

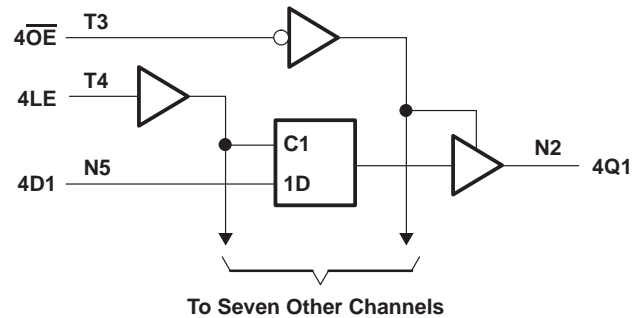
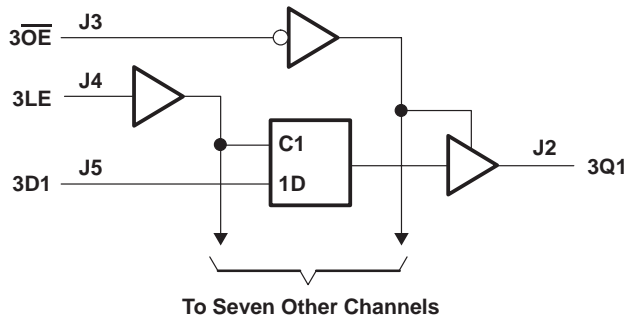
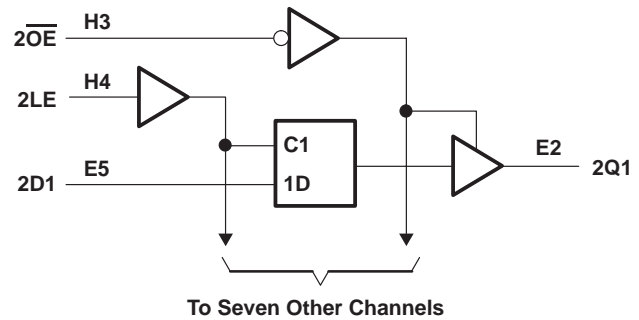
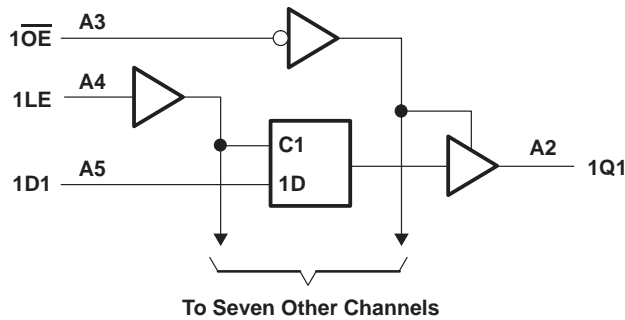

absolute maximum ratings over operating free-air temperature range (unless otherwise noted)†

Supply voltage range, V_{CC}	-0.5 V to 6.5 V
Input voltage range, V_I (see Note 1)	-0.5 V to 6.5 V
Voltage range applied to any output in the high-impedance or power-off state, V_O (see Note 1)	-0.5 V to 6.5 V
Voltage range applied to any output in the high or low state, V_O (see Notes 1 and 2)	-0.5 V to $V_{CC} + 0.5$ V
Input clamp current, I_{IK} ($V_I < 0$)	-50 mA
Output clamp current, I_{OK} ($V_O < 0$)	-50 mA
Continuous output current, I_O	± 50 mA
Continuous current through each V_{CC} or GND	± 100 mA
Package thermal impedance, θ_{JA} (see Note 3)	40°C/W
Storage temperature range, T_{stg}	-65°C to 150°C

† Stresses beyond those listed under "absolute maximum ratings" may cause permanent damage to the device. These are stress ratings only, and functional operation of the device at these or any other conditions beyond those indicated under "recommended operating conditions" is not implied. Exposure to absolute-maximum-rated conditions for extended periods may affect device reliability.

- NOTES: 1. The input negative-voltage and output voltage ratings may be exceeded if the input and output current ratings are observed.
 2. The value of V_{CC} is provided in the recommended operating conditions table.
 3. The package thermal impedance is calculated in accordance with JESD 51-7.

SN74LVCH32373A
32-BIT TRANSPARENT D-TYPE LATCH
WITH 3-STATE OUTPUTS

SCAS618D – OCTOBER 1998 – REVISED AUGUST 2003

recommended operating conditions (see Note 4)

		MIN	MAX	UNIT	
V _{CC}	Supply voltage	Operating	1.65	3.6	V
		Data retention only	1.5		
V _{IH}	High-level input voltage	V _{CC} = 1.65 V to 1.95 V	0.65 × V _{CC}		V
		V _{CC} = 2.3 V to 2.7 V	1.7		
		V _{CC} = 2.7 V to 3.6 V	2		
V _{IL}	Low-level input voltage	V _{CC} = 1.65 V to 1.95 V	0.35 × V _{CC}		V
		V _{CC} = 2.3 V to 2.7 V	0.7		
		V _{CC} = 2.7 V to 3.6 V	0.8		
V _I	Input voltage	0	5.5	V	
V _O	Output voltage	High or low state	0	V _{CC}	V
		3-state	0	5.5	
I _{OH}	High-level output current	V _{CC} = 1.65 V	-4		mA
		V _{CC} = 2.3 V	-8		
		V _{CC} = 2.7 V	-12		
		V _{CC} = 3 V	-24		
I _{OL}	Low-level output current	V _{CC} = 1.65 V	4		mA
		V _{CC} = 2.3 V	8		
		V _{CC} = 2.7 V	12		
		V _{CC} = 3 V	24		
Δt/Δv	Input transition rise or fall rate		10	ns/V	
T _A	Operating free-air temperature	-40	85	°C	

NOTE 4: All unused inputs of the device must be held at V_{CC} or GND to ensure proper device operation. Refer to the TI application report, *Implications of Slow or Floating CMOS Inputs*, literature number SCBA004.



SN74LVCH32373A

32-BIT TRANSPARENT D-TYPE LATCH WITH 3-STATE OUTPUTS

SCAS618D – OCTOBER 1998 – REVISED AUGUST 2003

electrical characteristics over recommended operating free-air temperature range (unless otherwise noted)

PARAMETER	TEST CONDITIONS	V _{CC}	MIN	TYP†	MAX	UNIT
V _{OH}	I _{OH} = -100 μA	1.65 V to 3.6 V	V _{CC} -0.2			V
	I _{OH} = -4 mA	1.65 V	1.2			
	I _{OH} = -8 mA	2.3 V	1.7			
	I _{OH} = -12 mA	2.7 V	2.2			
		3 V	2.4			
	I _{OH} = -24 mA	3 V	2.2			
V _{OL}	I _{OL} = 100 μA	1.65 V to 3.6 V			0.2	V
	I _{OL} = 4 mA	1.65 V			0.45	
	I _{OL} = 8 mA	2.3 V			0.7	
	I _{OL} = 12 mA	2.7 V			0.4	
	I _{OL} = 24 mA	3 V			0.55	
I _I	V _I = 0 to 5.5 V	3.6 V			±5	μA
I _I (hold)	V _I = 0.58 V	1.65 V			25	μA
	V _I = 1.07 V				-25	
	V _I = 0.7 V	2.3 V			45	
	V _I = 1.7 V				-45	
	V _I = 0.8 V	3 V			75	
	V _I = 2 V				-75	
	V _I = 0 to 3.6 V‡	3.6 V			±500	
I _{off}	V _I or V _O = 5.5 V	0			±10	μA
I _{OZ}	V _O = 0 to 5.5 V	3.6 V			±10	μA
I _{CC}	V _I = V _{CC} or GND	3.6 V			40	μA
	3.6 V ≤ V _I ≤ 5.5 V§		I _O = 0		40	
ΔI _{CC}	One input at V _{CC} - 0.6 V, Other inputs at V _{CC} or GND	2.7 V to 3.6 V			500	μA
C _i	V _I = V _{CC} or GND	3.3 V			5	pF
C _o	V _O = V _{CC} or GND	3.3 V			6.5	pF

† All typical values are at V_{CC} = 3.3 V, T_A = 25°C.

‡ This is the bus-hold maximum dynamic current. It is the minimum overdrive current required to switch the input from one state to another.

§ This applies in the disabled state only.

timing requirements over recommended operating free-air temperature range (unless otherwise noted) (see Figure 1)

		V _{CC} = 1.8 V ± 0.15 V		V _{CC} = 2.5 V ± 0.2 V		V _{CC} = 2.7 V		V _{CC} = 3.3 V ± 0.3 V		UNIT
		MIN	MAX	MIN	MAX	MIN	MAX	MIN	MAX	
t _w	Pulse duration, LE high	¶		¶		3.3		3.3		ns
t _{su}	Setup time, data before LE↓	¶		¶		1.7		1.7		ns
t _h	Hold time, data after LE↓	¶		¶		1.2		1.2		ns

¶ This information was not available at the time of publication.



SN74LVCH32373A
32-BIT TRANSPARENT D-TYPE LATCH
WITH 3-STATE OUTPUTS

SCAS618D – OCTOBER 1998 – REVISED AUGUST 2003

switching characteristics over recommended operating free-air temperature range (unless otherwise noted) (see Figure 1)

PARAMETER	FROM (INPUT)	TO (OUTPUT)	V _{CC} = 1.8 V ± 0.15 V		V _{CC} = 2.5 V ± 0.2 V		V _{CC} = 2.7 V		V _{CC} = 3.3 V ± 0.3 V		UNIT
			MIN	MAX	MIN	MAX	MIN	MAX	MIN	MAX	
t _{pd}	D	Q	†	†	†	†	4.9		1.6	4.2	ns
	LE		†	†	†	†	5.3		2.1	4.6	
t _{en}	\overline{OE}	Q	†	†	†	†	5.7		1.3	4.7	ns
t _{dis}	\overline{OE}	Q	†	†	†	†	6.3		2.5	5.9	ns

† This information was not available at the time of publication.

operating characteristics, T_A = 25°C

PARAMETER		TEST CONDITIONS	V _{CC} = 1.8 V	V _{CC} = 2.5 V	V _{CC} = 3.3 V	UNIT
			TYP	TYP	TYP	
C _{pd}	Power dissipation capacitance per latch	Outputs enabled	†	†	39	pF
		Outputs disabled	†	†	6	

† This information was not available at the time of publication.



PARAMETER MEASUREMENT INFORMATION

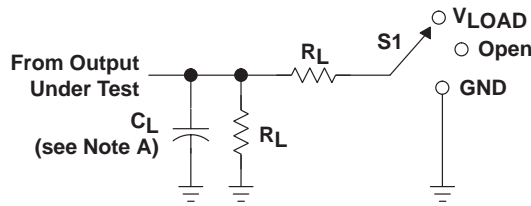

LOAD CIRCUIT

TEST	S1
t_{PLH}/t_{PHL}	Open
t_{PLZ}/t_{PZL}	V_{LOAD}
t_{PHZ}/t_{PZH}	GND

V_{CC}	INPUTS		V_M	V_{LOAD}	C_L	R_L	V_{Δ}
	V_I	t_r/t_f					
$1.8\text{ V} \pm 0.15\text{ V}$	V_{CC}	$\leq 2\text{ ns}$	$V_{CC}/2$	$2 \times V_{CC}$	30 pF	1 k Ω	0.15 V
$2.5\text{ V} \pm 0.2\text{ V}$	V_{CC}	$\leq 2\text{ ns}$	$V_{CC}/2$	$2 \times V_{CC}$	30 pF	500 Ω	0.15 V
2.7 V	2.7 V	$\leq 2.5\text{ ns}$	1.5 V	6 V	50 pF	500 Ω	0.3 V
$3.3\text{ V} \pm 0.3\text{ V}$	2.7 V	$\leq 2.5\text{ ns}$	1.5 V	6 V	50 pF	500 Ω	0.3 V

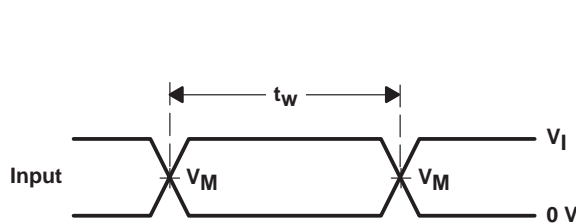

VOLTAGE WAVEFORMS
PULSE DURATION

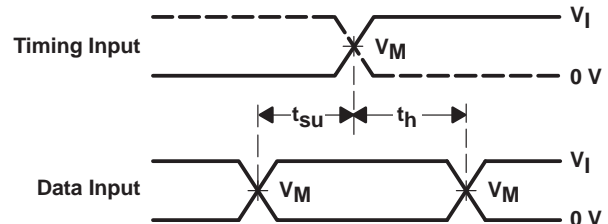

VOLTAGE WAVEFORMS
SETUP AND HOLD TIMES

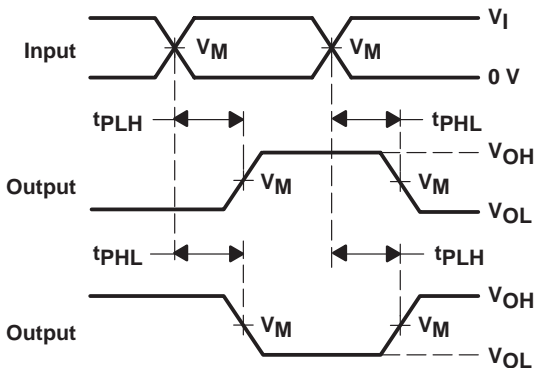

VOLTAGE WAVEFORMS
PROPAGATION DELAY TIMES
INVERTING AND NONINVERTING OUTPUTS

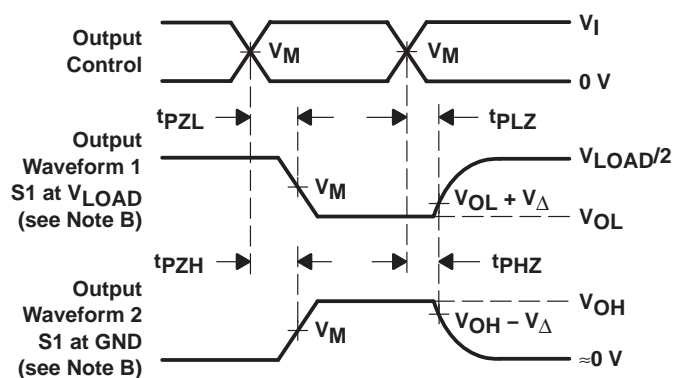

VOLTAGE WAVEFORMS
ENABLE AND DISABLE TIMES
LOW- AND HIGH-LEVEL ENABLING

- NOTES:
- A. C_L includes probe and jig capacitance.
 - B. Waveform 1 is for an output with internal conditions such that the output is low except when disabled by the output control. Waveform 2 is for an output with internal conditions such that the output is high except when disabled by the output control.
 - C. All input pulses are supplied by generators having the following characteristics: $PRR \leq 10\text{ MHz}$, $Z_O = 50\ \Omega$.
 - D. The outputs are measured one at a time with one transition per measurement.
 - E. t_{PLZ} and t_{PHZ} are the same as t_{dis} .
 - F. t_{PZL} and t_{PZH} are the same as t_{en} .
 - G. t_{PLH} and t_{PHL} are the same as t_{pd} .
 - H. All parameters and waveforms are not applicable to all devices.

Figure 1. Load Circuit and Voltage Waveforms

GKE (R-PBGA-N96)

PLASTIC BALL GRID ARRAY

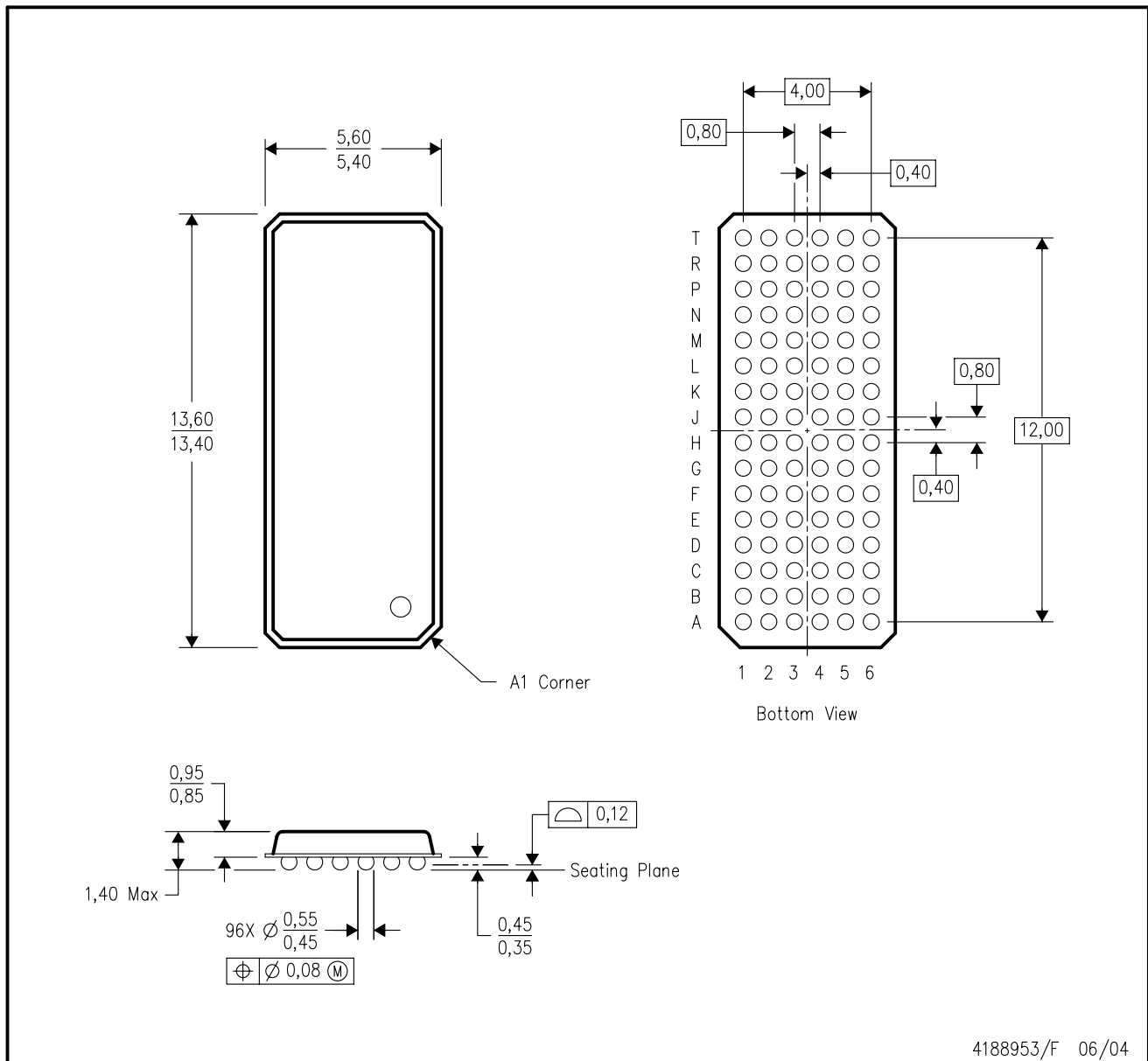

- NOTES:
- A. All linear dimensions are in millimeters.
 - B. This drawing is subject to change without notice.
 - C. Falls within JEDEC MO-205 variation CC.
 - D. This package is tin-lead (SnPb). Refer to the 96 ZKE package (drawing 4204493) for lead-free.

ZKE (R-PBGA-N96)

PLASTIC BALL GRID ARRAY

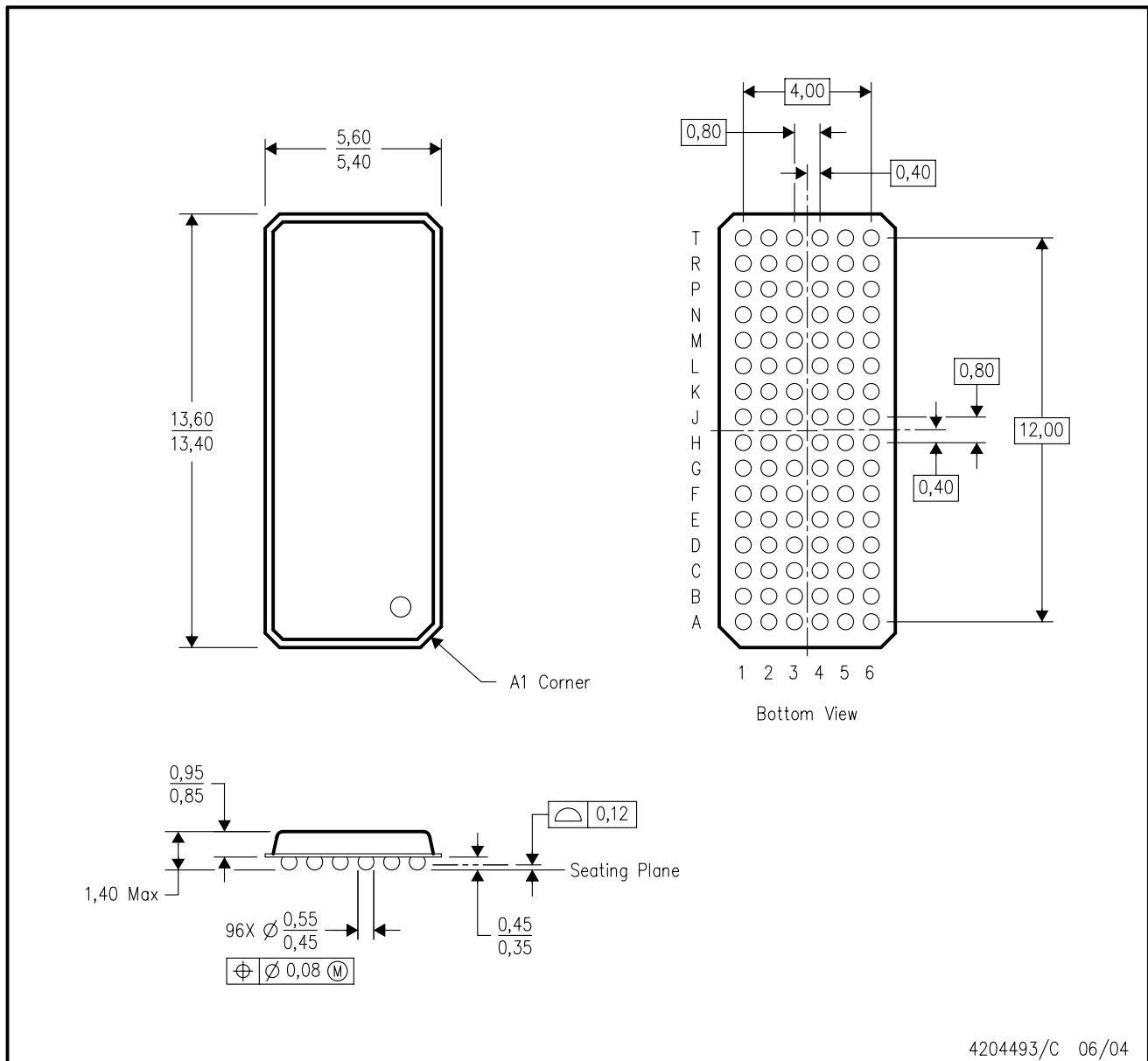

- NOTES:
- A. All linear dimensions are in millimeters.
 - B. This drawing is subject to change without notice.
 - C. Falls within JEDEC MO-205 variation CC.
 - D. This package is lead-free. Refer to the 96 GKE package (drawing 4188953) for tin-lead (SnPb).

IMPORTANT NOTICE

Texas Instruments Incorporated and its subsidiaries (TI) reserve the right to make corrections, modifications, enhancements, improvements, and other changes to its products and services at any time and to discontinue any product or service without notice. Customers should obtain the latest relevant information before placing orders and should verify that such information is current and complete. All products are sold subject to TI's terms and conditions of sale supplied at the time of order acknowledgment.

TI warrants performance of its hardware products to the specifications applicable at the time of sale in accordance with TI's standard warranty. Testing and other quality control techniques are used to the extent TI deems necessary to support this warranty. Except where mandated by government requirements, testing of all parameters of each product is not necessarily performed.

TI assumes no liability for applications assistance or customer product design. Customers are responsible for their products and applications using TI components. To minimize the risks associated with customer products and applications, customers should provide adequate design and operating safeguards.

TI does not warrant or represent that any license, either express or implied, is granted under any TI patent right, copyright, mask work right, or other TI intellectual property right relating to any combination, machine, or process in which TI products or services are used. Information published by TI regarding third-party products or services does not constitute a license from TI to use such products or services or a warranty or endorsement thereof. Use of such information may require a license from a third party under the patents or other intellectual property of the third party, or a license from TI under the patents or other intellectual property of TI.

Reproduction of information in TI data books or data sheets is permissible only if reproduction is without alteration and is accompanied by all associated warranties, conditions, limitations, and notices. Reproduction of this information with alteration is an unfair and deceptive business practice. TI is not responsible or liable for such altered documentation.

Resale of TI products or services with statements different from or beyond the parameters stated by TI for that product or service voids all express and any implied warranties for the associated TI product or service and is an unfair and deceptive business practice. TI is not responsible or liable for any such statements.

Following are URLs where you can obtain information on other Texas Instruments products and application solutions:

Products		Applications	
Amplifiers	amplifier.ti.com	Audio	www.ti.com/audio
Data Converters	dataconverter.ti.com	Automotive	www.ti.com/automotive
DSP	dsp.ti.com	Broadband	www.ti.com/broadband
Interface	interface.ti.com	Digital Control	www.ti.com/digitalcontrol
Logic	logic.ti.com	Military	www.ti.com/military
Power Mgmt	power.ti.com	Optical Networking	www.ti.com/opticalnetwork
Microcontrollers	microcontroller.ti.com	Security	www.ti.com/security
		Telephony	www.ti.com/telephony
		Video & Imaging	www.ti.com/video
		Wireless	www.ti.com/wireless

Mailing Address: Texas Instruments
Post Office Box 655303 Dallas, Texas 75265