

SYNCHRONOUS SWITCHMODE, LI-ION AND LI-POL CHARGE MANAGEMENT IC WITH INTEGRATED POWERFETS (bqSWITCHER™)

FEATURES

- Ideal For High-Efficient Charger Designs For Single-, Two- or Three-Cell Li-Ion and Li-Pol Battery Packs
- Integrated Synchronous Fixed-Frequency PWM Controller Operating at 1.1 MHz with 0 to 100% Duty Cycle
- Integrated PowerFETs For Up To 2-A Charge Rate
- High-Accuracy Voltage and Current Regulation
- Available In Both Standalone (Built-In Charge Management and Control) and System-Controlled (Under System Command) Versions
- Status Outputs For LED or Host Processor Interface Indicates Charge-In-Progress, Charge Completion, Fault and AC-Adapter Present Conditions
- 20-V Input Voltage Rating
- High-Side Current Sensing
- Optional Battery Temperature Monitoring
- Automatic Sleep Mode for Low Power Consumption
- System-Controlled Version Can Be Used In NiMH and NiCd Applications
- Uses Ceramic Capacitors
- Reverse Leakage Protection Prevents Battery Drainage
- Thermal Shutdown and Protection
- Built-In Battery Detection

DESCRIPTION

The bqSWITCHER™ series are highly integrated Li-Ion and Li-Pol switch-mode charge management devices targeted at a wide range of portable applications. The bqSWITCHER™ series offer integrated synchronous PWM controller and PowerFETs, high-accuracy current and voltage regulation, charge preconditioning, charge status, and charge termination, in a small thermally enhanced QFN package. The system controlled version provides additional inputs for full charge management under system control.

The bqSWITCHER charges the battery in three phases: conditioning, constant current, and constant voltage. Charge is terminated based on user-selectable minimum current level. A programmable charge timer provides a safety backup safety for charge termination. The bqSWITCHER automatically re-starts the charge cycle if the battery voltage falls below an internal threshold. The bqSWITCHER automatically enters sleep mode when V_{CC} supply is removed.

APPLICATIONS

- Handheld Products
- Portable Media Players
- Industrial and Medical Equipment
- Portable Equipment



Please be aware that an important notice concerning availability, standard warranty, and use in critical applications of Texas Instruments semiconductor products and disclaimers thereto appears at the end of this data sheet.

bqSWITCHER™ is a trademark of Texas Instruments Incorporated.

PRODUCTION DATA information is current as of publication date. Products conform to specifications per the terms of Texas Instruments standard warranty. Production processing does not necessarily include testing of all parameters.

ABSOLUTE MAXIMUM RATINGS⁽³⁾

			UNIT
Supply voltage range, (with respect to V_{SS})	IN, VCC	20	V
Input voltage range, (with respect to V_{SS} and PGND)	STAT1, STAT2, \overline{PG} , \overline{CE} , CELLS, SNS, BAT	-0.3 to 20	
	OUT	-0.7 to 20	
	CMODE, TS, TTC	7	
	VTSB	3.6	
	ISET1, ISET2	3.3	
Voltage difference between SNS and BAT inputs ($V_{SNS} - V_{BAT}$)		± 1	
Output sink/source current	STAT1, STAT2, \overline{PG}	10	mA
Output current	OUT	2.2	A
Operating free-air temperature range, T_A		-40 to 85	°C
Junction temperature range, T_J		-40 to 125	
Storage temperature, T_{Stg}		-65 to 150	
Lead temperature 1,6 mm (1/16 inch) from case for 10 seconds		300	

(3) Stresses beyond those listed under “absolute maximum ratings” may cause permanent damage to the device. These are stress ratings only, and functional operation of the device at these or any other conditions beyond those indicated under “recommended operating conditions” is not implied. Exposure to absolute-maximum-rated conditions for extended periods may affect device reliability.

RECOMMENDED OPERATING CONDITIONS

	MIN	NOM	MAX	UNIT
Supply voltage, V_{CC}	3.5		16.0	V
Operating junction temperature range, T_J	-40		125	°C

ELECTRICAL CHARACTERISTICS

$T_J = 0^\circ\text{C}$ to 125°C and recommended supply voltage range (unless otherwise stated)

PARAMETER	TEST CONDITIONS	MIN	TYP	MAX	UNIT
INPUT CURRENTS					
$I_{VCC(VCC)}$ V_{CC} supply current	$V_{CC} > V_{CC(min)}$, PWM switching		10		mA
	$V_{CC} > V_{CC(min)}$, PWM NOT switching			5	
	$V_{CC} > V_{CC(min)}$, $\overline{CE} = \text{HIGH}$				315
$I_{CC(SLP)}$ Sleep current	$0^\circ\text{C} \leq T_J \leq 65^\circ\text{C}$, $V_{I(BAT)} = 4.2\text{ V}$ $V_{CC} < V_{I(SLP)}$ or $V_{CC} > V_{I(SLP)}$ but not in charge			3.5	μA
	$0^\circ\text{C} \leq T_J \leq 65^\circ\text{C}$, $V_{I(BAT)} = 8.2\text{ V}$ $V_{CC} < V_{I(SLP)}$ or $V_{CC} > V_{I(SLP)}$ but not in charge			5.5	
	$0^\circ\text{C} \leq T_J \leq 65^\circ\text{C}$, $V_{I(BAT)} = 12.6\text{ V}$ $V_{CC} < V_{I(SLP)}$ or $V_{CC} > V_{I(SLP)}$ but not in charge			7.7	
VOLTAGE REGULATION					
V_{OREG} Output voltage	CELLS = Low		4.20		V
	CELLS = High		8.40		
Voltage regulation accuracy	$T_A = 25^\circ\text{C}$		-0.5%	0.5%	
			-1%	1%	

ELECTRICAL CHARACTERISTICS (continued)

T_J = 0°C to 125°C and recommended supply voltage range (unless otherwise stated)

PARAMETER		TEST CONDITIONS	MIN	TYP	MAX	UNIT
CURRENT REGULATION						
I _{O(OUT)}	Output current range	V _{LOWV} ≤ V _{I(BAT)} ≤ V _{OREG} , V(VCC) - V _{I(BAT)} > V(DO-MAX)	150		2000	mA
	Current regulation accuracy	V(VCC) ≥ V _{CC(min)} , V _{LOWV} ≤ V _{I(BAT)} ≤ V _{OREG} , V(VCC) ≥ V _{I(BAT)} + V(DO-MAX), Over output current range. Does not include error induced by the tolerance of resistor, R _{SET} , on the ISETx pin, or the sense resistor, R(SNS)	-10%		10%	
V _{IREG}	Current regulation differential threshold voltage range	V _{I(SNS)} - V _{I(BAT)} , V(VCC) ≥ V _{I(BAT)} + V(DO-MAX), V _{LOWV} ≤ V _{I(BAT)} ≤ V _{OREG}	100		200	mV
V(ISET1)	Output current set voltage	V(VCC) ≥ V _{CC(min)} , V _{LOWV} ≤ V _{I(BAT)} ≤ V _{O(REG)} , V(VCC) ≥ V _{I(BAT)} + V(DO-MAX)		1		V
K(ISET1)	Output current set factor	V(VCC) ≥ V _{CC(min)} , V _{LOWV} ≤ V _{I(BAT)} ≤ V _{O(REG)} , V(VCC) ≥ V _{I(BAT)} + V(DO-MAX)		1000		V/A
PRE-CHARGE AND SHORT-CIRCUIT CURRENT REGULATION						
V _{LOWV}	Precharge to fast-charge transition voltage threshold, BAT		68.0%	71.4%	75.0%	V _{O(REG)}
t	Deglitch time for precharge to fast charge transition	Rising voltage; t _{RISE} , t _{FALL} = 100 ns, 2 mV overdrive	20	30	40	ms
I _{OPRECHG}	Precharge range	V _{I(BAT)} < V _{LOWV} , t < t _{PRECHG}	15		200	mA
V(ISET2)	Precharge set voltage, ISET2	V _{I(BAT)} < V _{LOWV} , t < t _{PRECHG}		100		mV
K(ISET2)	Precharge current set factor			1000		V/A
	Precharge current regulation accuracy	0 V ≤ V _{I(BAT)} < V _{LOWV} , 10 mV ≤ [V _{I(SNS)} - V _{I(BAT)}] ≤ 100 mV	-20%		20%	
V _{SHORT}	Short-circuit voltage threshold, BAT	V _{I(BAT)} falling	1.95	2.00	2.05	V/cell
I _{SHORT}	Short-circuit current	V _{I(BAT)} ≤ V _{SHORT}	35		65	mA
CHARGE TERMINATION (CURRENT TAPER) DETECTION						
I _{TERM}	Charge current termination detection range	V _{I(BAT)} < V _{RCH}	15		200	mA
V _{TERM}	Charge termination detection set voltage, ISET2	V _{I(BAT)} < V _{RCH}		100		mV
K(ISET2)	Termination current set factor			1000		V/A
	Charger termination accuracy	V _{I(BAT)} < V _{RCH} , 10 mV ≤ [V _{I(SNS)} - V _{I(BAT)}] ≤ 100 mV	-20%		20%	
t	Deglitch time for charge termination	Both rising and falling, t _{RISE} , t _{FALL} = 100 ns 2 mV overdrive	20	30	40	ms
TEMPERATURE COMPARATOR AND VTSB BIAS REGULATOR						
V _{LTF}	Cold temperature threshold, TS		72.8	73.5	74.2	% V _{O(VTSB)}
V _{HTF}	Hot temperature threshold, TS		33.7	34.4	35.1	
V _{TCO}	Cutoff temperature threshold, TS		28.7	29.3	29.9	
	LTF hysteresis		0.5	1.0	1.5	
t	Deglitch time for temperature fault, TS	Both rising and falling, t _{RISE} , t _{FALL} = 100 ns 2 mV overdrive	20	30	40	ms
V _{O(VTSB)}	Output voltage	V _{CC} > 4.5 V, I(VTSB) = 10 mA C _{O(VTSB)} = 0.1 μF		3.15		V
V _{O(VTSB)}	Voltage regulation accuracy	V _{CC} > 4.5 V, I(VTSB) = 10 mA C _{O(VTSB)} = 0.1 μF	-10%		10%	

ELECTRICAL CHARACTERISTICS (continued)

T_J = 0°C to 125°C and recommended supply voltage range (unless otherwise stated)

PARAMETER		TEST CONDITIONS	MIN	TYP	MAX	UNIT
BATTERY RECHARGE THRESHOLD						
V _{RCH}	Recharge threshold voltage	Below V _{OREG}	75	100	125	mV/cell
t	Deglintch time	V _{I(BAT)} < decreasing below threshold, t _{FALL} = 100 ns 10 mV overdrive	20	30	40	ms
STAT1, STAT2 AND PG OUTPUTS						
V _{OL(STATx)}	Low-level output saturation voltage, STAT _x	I _O = 5 mA			0.5	V
V _{OL(PG)}	Low-level output saturation voltage, PG	I _O = 10 mA			0.1	
CE CMODE, CELLS INPUTS						
V _{IL}	Low-level input voltage	I _{IL} = 5 μA	0.0		0.4	V
V _{IH}	High-level input voltage	I _{IH} = 20 μA	1.3		V _{CC}	
TTC INPUT						
t _{PRECHG}	Precharge timer		1440	1800	2160	s
t _{CHARGE}	Programmable charge timer range	t(CHG) = C(TTC) × K(TTC)	25		480	minutes
	Charge timer accuracy		-10%		10%	
K _{PROG}	Timer multiplier			155		s/nF
C _{PROG}	Charge time capacitor range		0.001		0.22	μF
V _{TTC_EN}	TTC enable threshold voltage	V(TTC) rising		200		mV
SLEEP COMPARATOR						
V _{SLP-ENT}	Sleep-mode entry threshold	2.3 V ≤ V _{I(OUT)} ≤ V _{OREG}	V _{CC} ≤ V _{I(OUT)} +5 mV		V _{CC} ≤ V _{I(OUT)} +75mV	V
		V _{I(OUT)} = 12.6 V, R _{IN} = 1 kΩ (1)	V _{CC} ≤ V _{I(OUT)} -4 mV		V _{CC} ≤ V _{I(OUT)} +73mV	
V _{SLP-EXIT}	Sleep-mode exit hysteresis,	2.3 V ≤ V _{I(OUT)} ≤ V _{OREG}	40		160	mV
t	Deglintch time for sleep mode	V _{CC} decreasing below threshold, t _{FALL} = 100 ns, 10 mV overdrive, PMOS turns off		5		μs
		V _{CC} increasing below threshold, t _{FALL} = 100 ns, 10 mV overdrive, STATx pins turn off	20	30	40	ms
UVLO						
V _{OVLO-ON}	Turn-on threshold voltage	Rising	3.15	3.30	3.50	V
	Turn-on hysteresis	Falling	120	150		mV
PWM						
	Internal P-channel MOSFET on-resistance	7 V ≤ V _{CC} ≤ V _{CC(max)}			400	mΩ
		4.5 V ≤ V _{CC} ≤ 7 V			500	
	Internal N-channel MOSFET on-resistance	7 V ≤ V _{CC} ≤ V _{CC(max)}			130	
		4.5 V ≤ V _{CC} ≤ 7 V			150	
f _{OSC}	Oscillator frequency			1.1		MHz
	Frequency accuracy		9%		9%	
D _{MAX}	Maximum duty cycle		100%			
D _{MIN}	Minimum duty cycle				0%	

(1) For bq24105 and bq24115 only. R_{IN} is connected between IN and PGND pins and needed to ensure sleep entry.

**bq24100, bq24103, bq24105
bq24113, bq24115**

SLUS606 – JUNE 2004

ELECTRICAL CHARACTERISTICS NIL

T_J = 0°C to 125°C and recommended supply voltage range (unless otherwise stated)

PARAMETER		TEST CONDITIONS	MIN	TYP	MAX	UNIT
BATTERY DETECTION						
I _{DETECT}	Battery detection current during time-out fault	V _{I(BAT)} < V _{O(REG)}		2		mA
I _{DISCHRG1}	Discharge current	V _{SHORT} < V _{I(BAT)} < V _{O(REG)}		400		μA
t _{DISCHRG1}	Discharge time	V _{SHORT} < V _{I(BAT)} < V _{O(REG)}		1		s
I _{WAKE}	Wake current	V _{SHORT} < V _{I(BAT)} < V _{O(REG)}		2		mA
t _{WAKE}	Wake time	V _{SHORT} < V _{I(BAT)} < V _{O(REG)}		0.5		s
I _{DISCHRG2}	Termination discharge current	Begins after termination detected, V _{I(BAT)} ≤ V _{O(REG)}		400		μA
t _{DISCHRG2}	Termination time			262		ms
	Required output ceramic capacitor from BAT to V _{SS}		4.7	10	47	μF
PROTECTION						
V _{OVP}	OVP threshold voltage	Threshold over V _{O(REG)} to turn-off P-channel MOSFET, STAT1 and STAT2 during charge or termination states	110	117	121	V _{O(REG)}
	Cycle-by-cycle current limit		2.6	3.6	4.5	A
	N-channel MOSFET current turn-off threshold voltage		50		400	mA
V _{SHORT}	Short-circuit voltage threshold, BAT	V _{I(BAT)} falling	1.95	2.00	2.05	V/cell
I _{SHORT}	Short-circuit current	V _{I(BAT)} ≤ V _{SHORT}	35		65	mA
TSHTDWN	Thermal trip			165		°C
	Thermal hysteresis			10		

**RHL PACKAGE
(BOTTOM VIEW)**

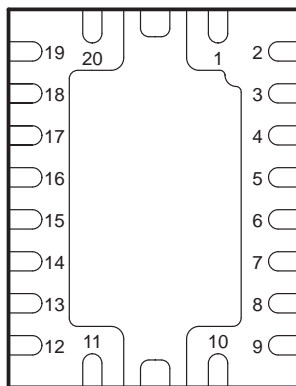

TERMINAL FUNCTIONS

NAME	TERMINAL NO.					I/O	Description
	bq24100	bq24103	bq24105	bq24113	bq24115		
BAT	14	14	14	14	14	I	Battery voltage sense input. Bypass it with a capacitor close to the pin.
$\overline{\text{CE}}$	16	16	16	16	16	I	Charger enable input. This active low input is used to suspend charge and place the device in the low-power sleep mode. Do not pull up this input to VTSB.
CELLS		13		13		I	Available on parts with fix output voltage. Ground or float for single cell operation (4.2 V). For two cells operation (8.4 V) pull up this pin with a resistor to V _{CC} .
CMODE				7	7	I	Charge mode selection: low for precharge as set by ISET2 pin and high for fast charge as set by ISET1.
FB			13		13	I	Output voltage analog feedback adjustment. Connect the output of a resistive voltage divider powered from the battery terminals to this node to adjust the output battery voltage regulation.
IN	3,4	3,4	3,4	3,4	3,4	I	Charger input voltage.
ISET1	8	8	8	8	8	I/O	Charger current set point 1 (fast charge). Use a resistor to ground to set this value.
ISET2	9	9	9	9	9	I/O	Charge current set point 2 (precharge and termination), set by a resistor connected to ground. A high-level CMODE signal forces this condition, but if the battery voltage reaches the regulation set point, bqSWITCHER changes to voltage regulation regardless of CMODE input.
N/C	13			19	19	–	No connection. This pin must be left floating in the application.
OUT	1	1	1	1	1	O	Charge current output inductor connection.
	20	20	20	20	20	O	
$\overline{\text{PG}}$	5	5	5	5	5	O	Powergood status output (open drain). The transistor turns on when a valid V _{CC} is detected. It is turned-off in the sleep mode. $\overline{\text{PG}}$ can be used to drive a LED or communicate with a host processor.
PGND	17,18			17,18	17, 18		Power ground input
SNS	15	15	15	15	15	I	Charge current sense input. Battery current is sensed via the voltage drop developed on this pin by an external sense resistor in series with the battery pack.
STAT1	2	2	2	2	2	O	Charge status 1 (open drain output). When the transistor turns on indicates charge in process. When it is off and in conjunction with the condition of STAT2 indicates various charger conditions (See Figure 6)
STAT2	19	19	19			O	Charge status 2 (open drain output). When the transistor turns on indicates charge is done. When it is off and in conjunction with the condition of STAT1 indicates various charger conditions (See Figure 6)
TS	12	12	12	12	12	I	Temperature sense input. This input monitors its voltage against an internal threshold to determine if charging is allowed. Use an NTC thermistor and a voltage divider powered from VTSB to develop this voltage.
TTC	7	7	7			I	Timer and termination control. Connect a capacitor from this node to GND to set the bqSWITCHER timer. When this input is low the timer and termination detection are disabled.

**bq24100, bq24103, bq24105
bq24113, bq24115**

SLUS606 – JUNE 2004

NAME	TERMINAL					I/O	Description
	NO.						
	bq24100	bq24103	bq24105	bq24113	bq24115		
VCC	6	6	6	6	6	I	Analog device input
VSS	10	10	10	10	10		Analog ground input
VTSB	11	11	11	11	11	O	TS internal bias regulator voltage. Connect capacitor (with a value between a 0.1 μ F and 1- μ F between this output and VSS.
Exposed Thermal Pad	Pad	Pad	Pad	Pad	Pad		There is an internal electrical connection between the exposed thermal pad and VSS. The exposed thermal pad must be connected to the same potential as the VSS pin on the printed circuit board, Do not use the thermal pad as the primary ground input for the V _{CC} . VSS pin must be connected to ground all the times.

FUNCTIONAL BLOCK DIAGRAM

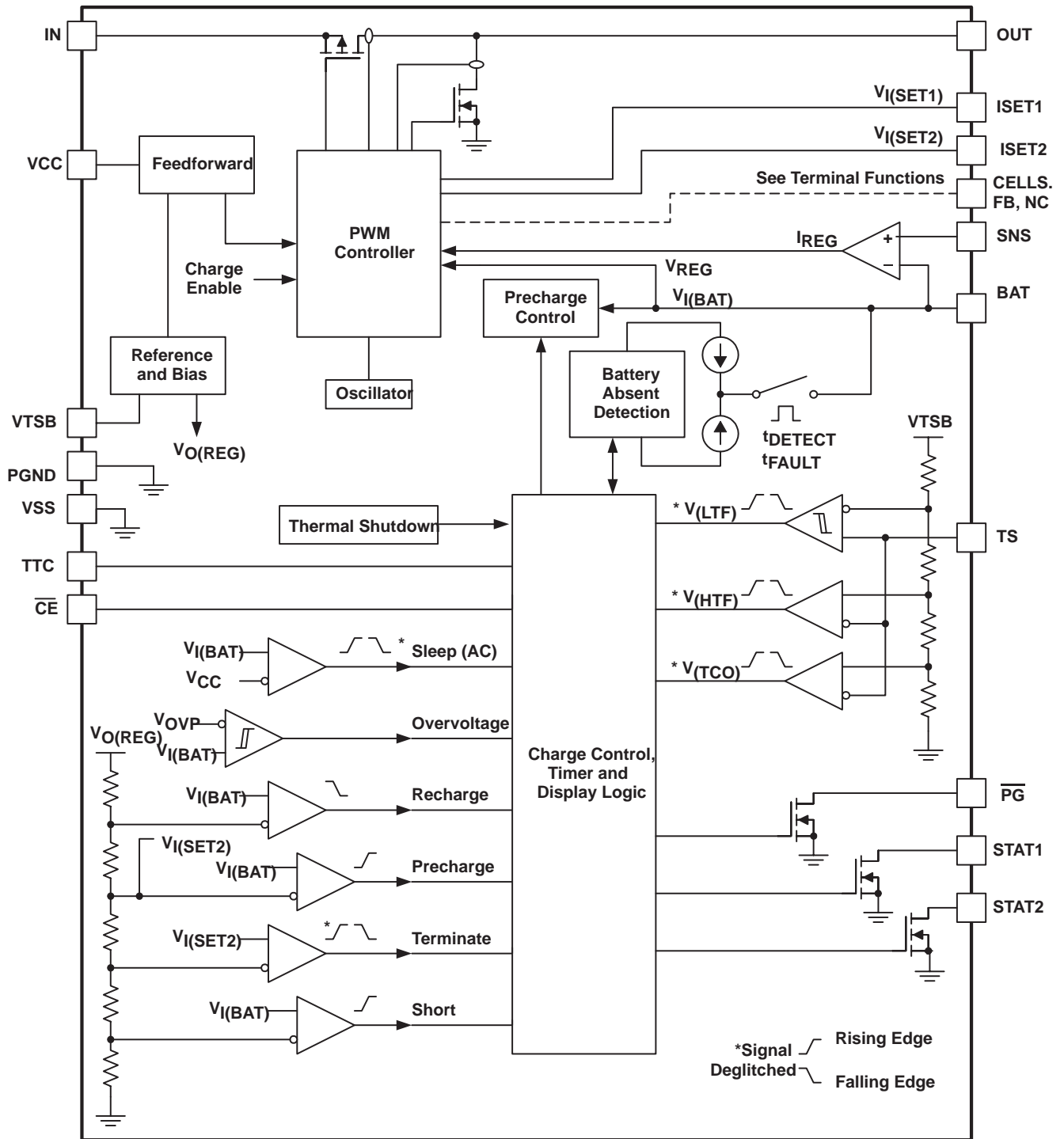

UDG-04034

TYPICAL CHARACTERISTICS

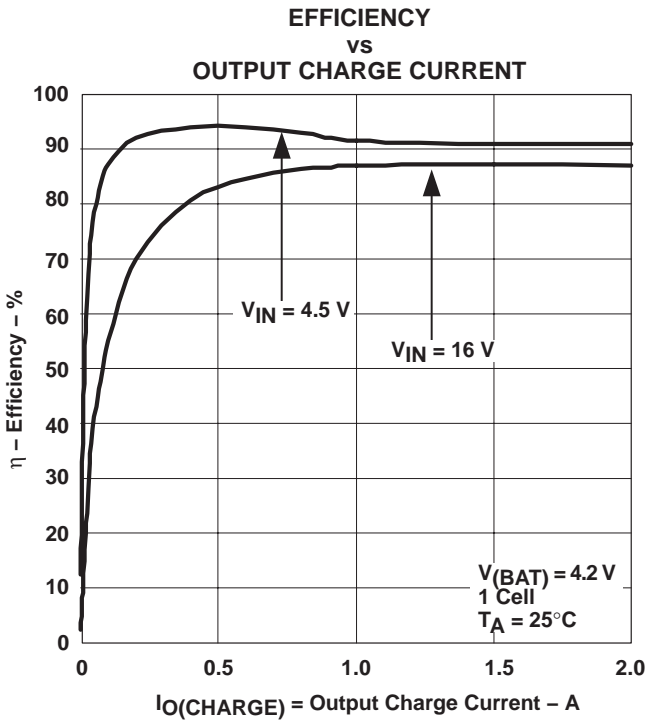

Figure 1

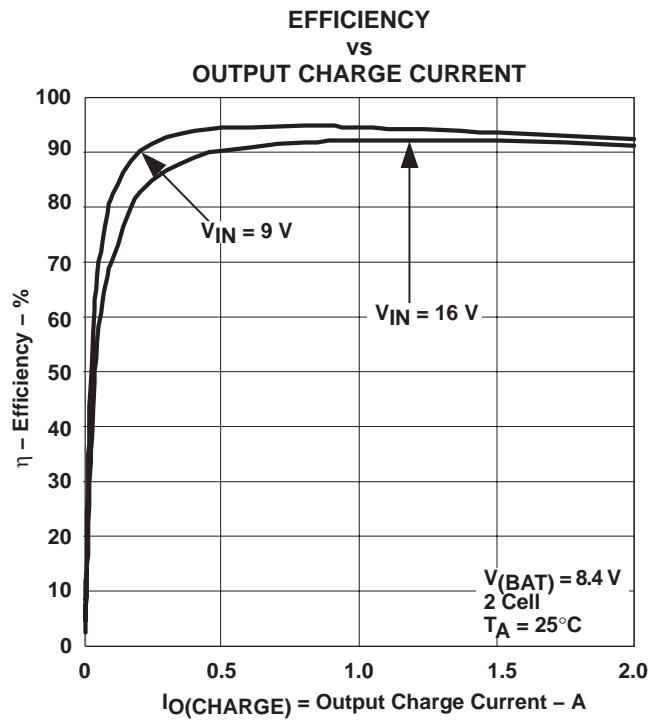
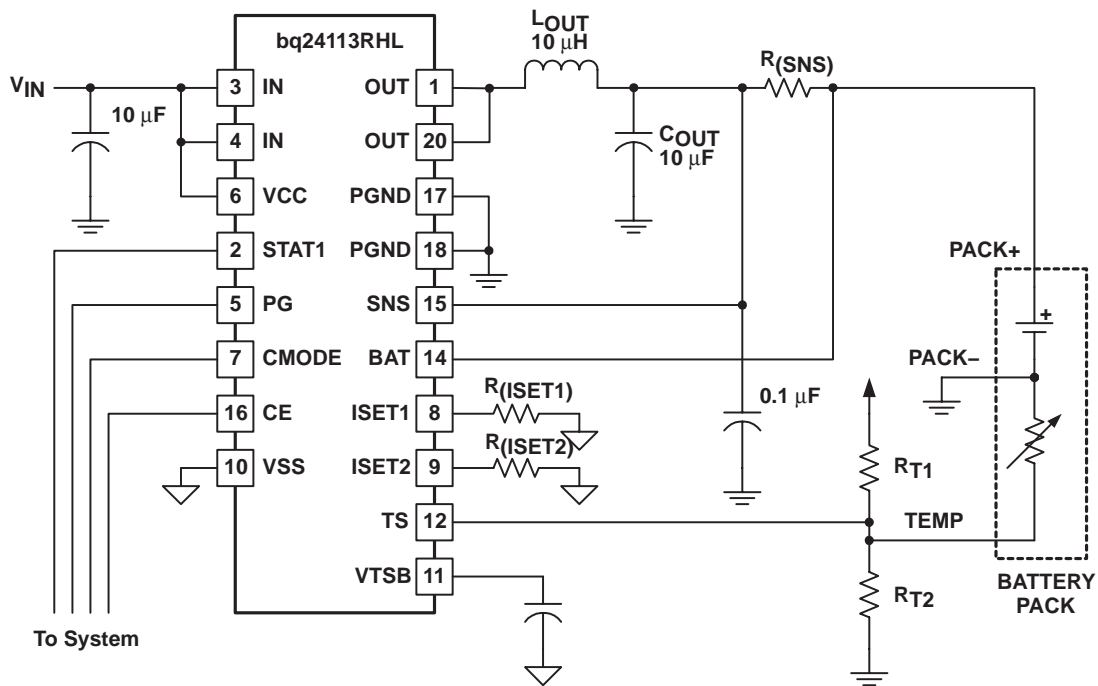

Figure 2



UDG-04035

Figure 3. Typical Application Circuit (System-Controlled Version)

APPLICATION INFORMATION

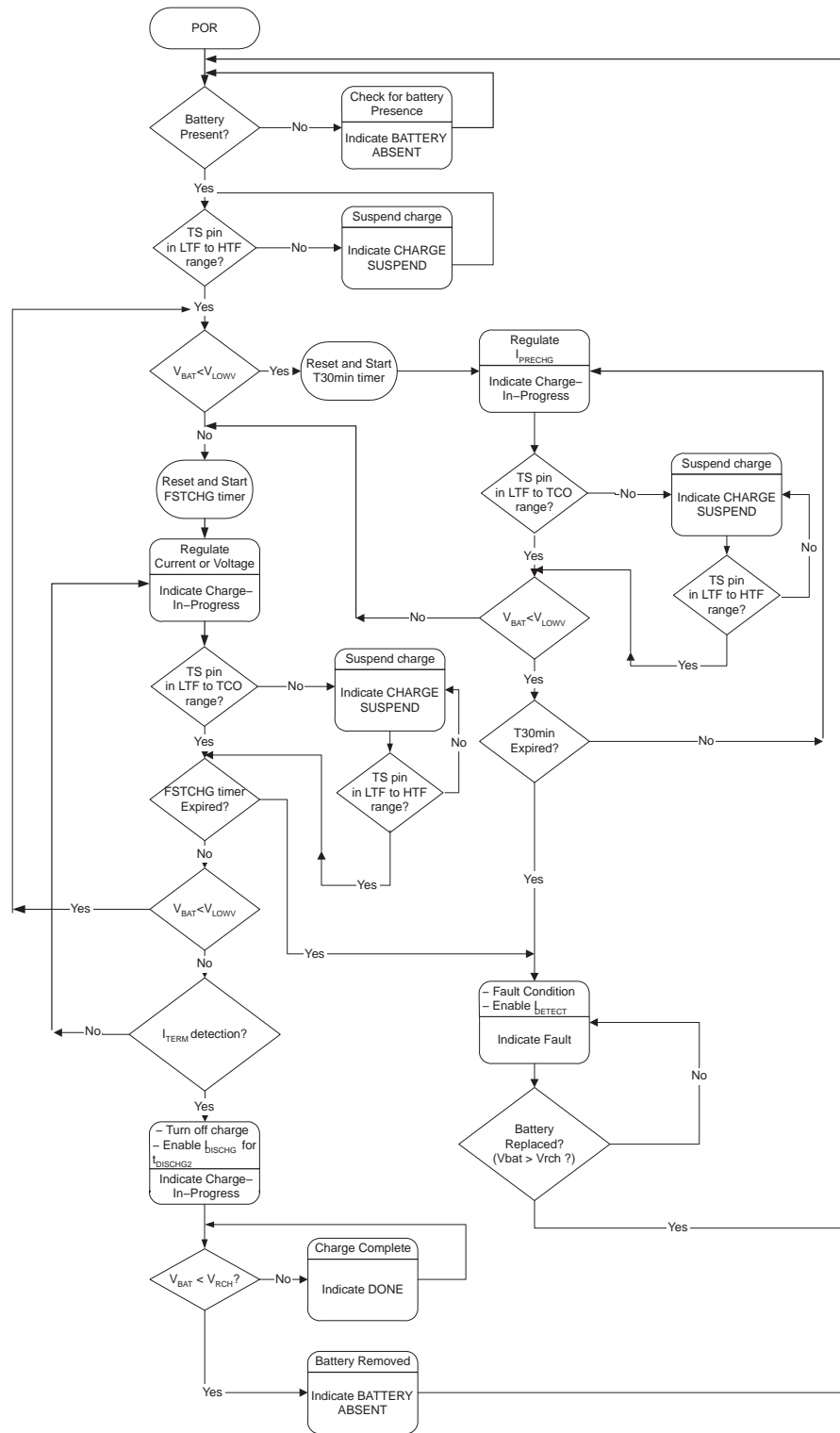

Figure 4. Standalone Version Operational Flow Chart

APPLICATION INFORMATION

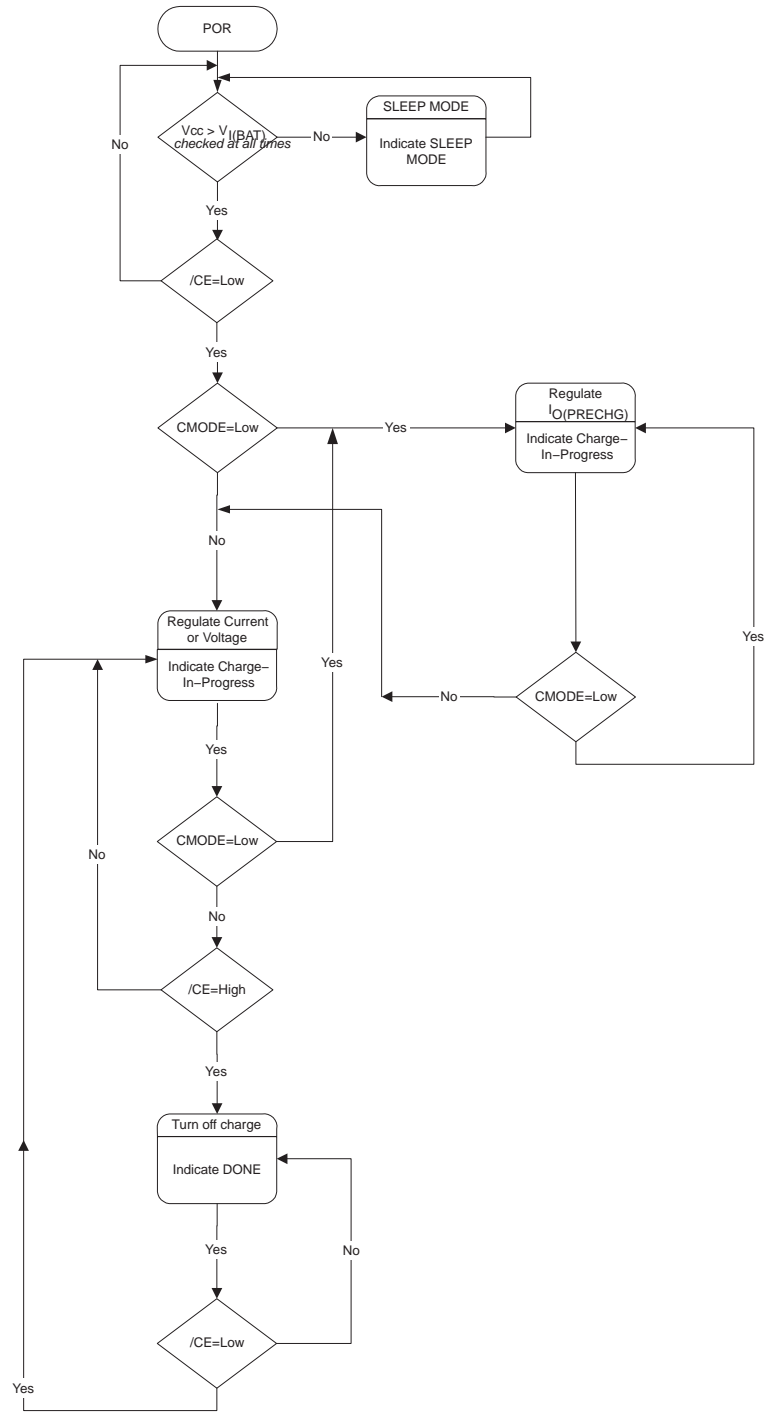
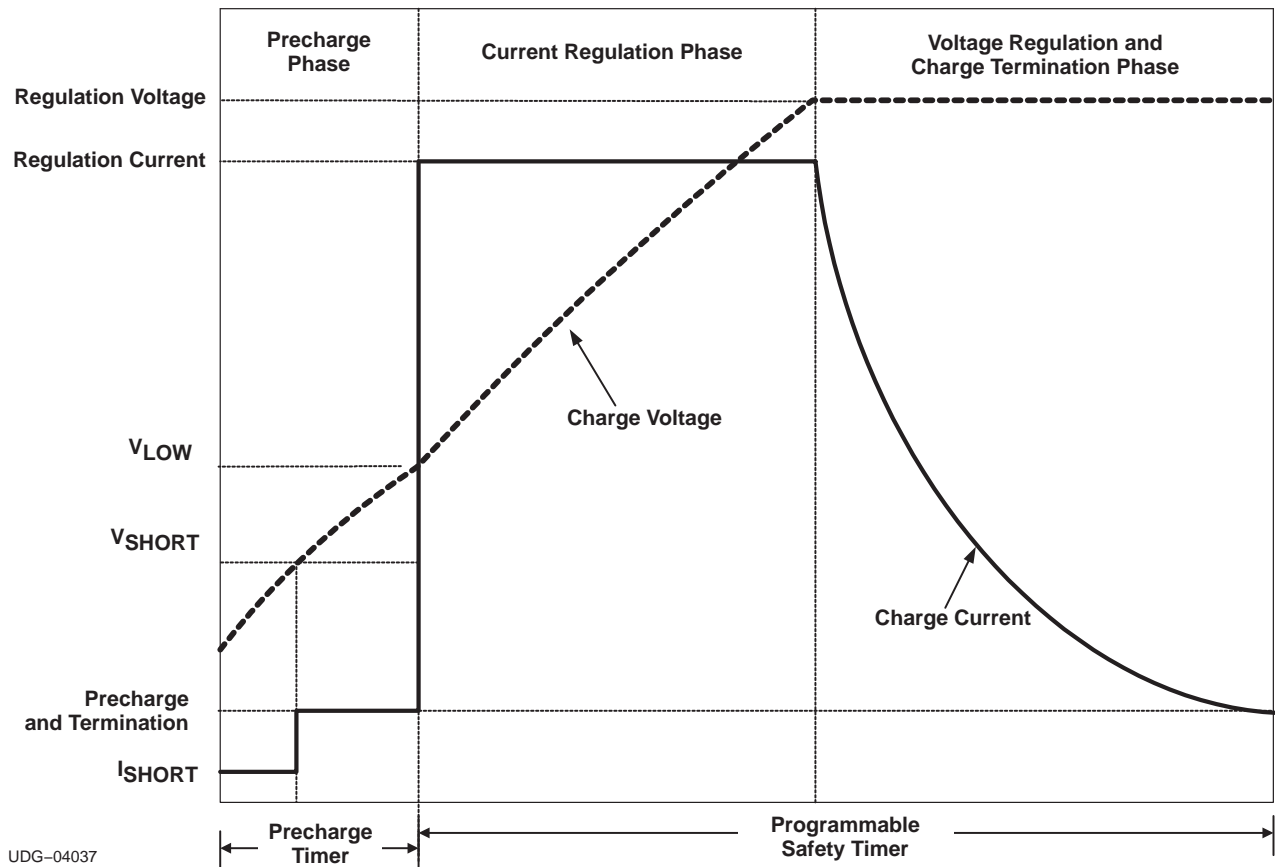

Figure 5. System Controlled Operational Flow Chart

APPLICATION INFORMATION

FUNCTIONAL DESCRIPTION FOR STANDALONE VERSION (bq2410x)

The bqSWITCHER™ supports a precision Li-Ion or Li-Pol charging system for single-, two- or three-cell applications. See Figures 4 and 5 for an operational flow charts and Figure 6 for a typical charge profile.



UDG-04037

Figure 6. Typical Charging Profile

Temperature Qualification

The bqSWITCHER continuously monitors battery temperature by measuring the voltage between the TS pin and VSS. A negative temperature coefficient thermistor (NTC) and an external voltage divider typically develop this voltage. The bqSWITCHER compares this voltage against its internal thresholds to determine if charging is allowed. To initiate a charge cycle, the battery temperature must be within the V_(LTF)-to-V_(HTF) thresholds. If battery temperature is outside of this range, the bqSWITCHER suspends charge and waits until the battery temperature is within the V_(LTF)-to-V_(HTF) range. During the charge cycle (both pre-charge and fast charge) the battery temperature must be within the V_(LTF)-to-V_(TCO) thresholds. If battery temperature is outside of this range, the bqSWITCHER suspends charge and waits until the battery temperature is within the V_(LTF)-to-V_(HTF) range. The bqSWITCHER suspends charge by turning off the PWM and holding the timer value (i.e. timers are not reset during a suspend condition). Note that the bias for the external resistor divider is provided from the VTSB output. Applying a constant voltage between the V_(LTF)-to-V_(HTF) thresholds to TS pin disables the temperature-sensing feature.

APPLICATION INFORMATION

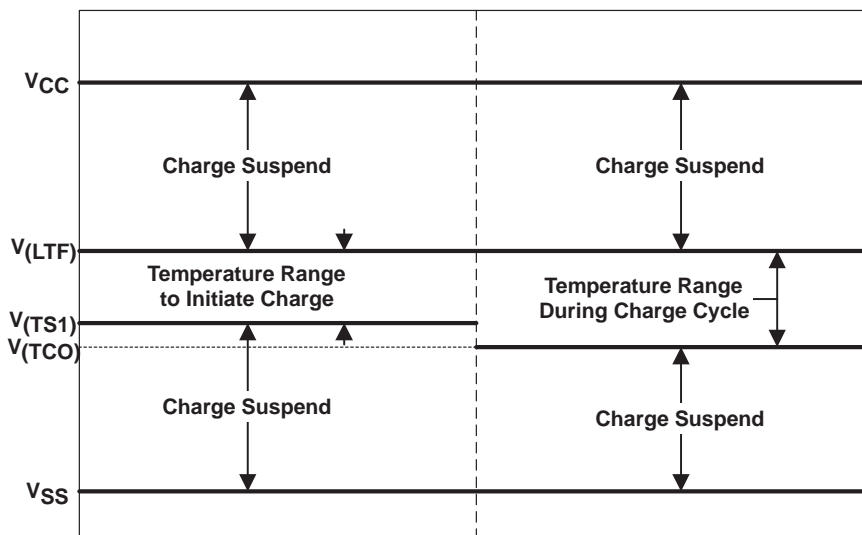

Figure 7. TS Pin Thresholds

Battery Preconditioning (Precharge)

Upon power-up, if the battery voltage is below the V_{LOWV} threshold, the bqSWITCHER applies a pre-charge current, I_{PRECHG}, to the battery. This feature revives deeply discharged cells. The bqSWITCHER activates a safety timer, t_{PRECHG}, during the conditioning phase. If V_{LOWV} threshold is not reached within the timer period, the bqSWITCHER turns off the charger and enunciates FAULT on the STATx pins. In the case of a FAULT condition, the bqSWITCHER reduces the current to I_{DETECT}. I_{DETECT} is used to detect a battery replacement condition. Fault condition is cleared by POR or battery replacement.

The magnitude of the pre-charge current, I_{O(PRECHG)}, is determined by the value of programming resistor, R_(ISET2), connected to the ISET2 pin.

$$I_{O(PRECHG)} = \frac{K_{(ISET2)} \times V_{(ISET2)}}{(R_{(ISET2)} \times R_{(SNS)})} \tag{1}$$

where

- R_{SNS} is the external current sense resistor
- V_(ISET2) is the output of the ISET2 pin
- K_(ISET2) is the output current set factor
- V_(ISET2) and K_(ISET2) are specified in the Electrical Characteristics table.

Battery Charge Current

The battery charge current, I_{O(CHARGE)}, is established by setting the external sense resistor, R_(SNS), and the resistor, R_(ISET1), connected to the ISET1 pin.

In order to set the current, first R_(SNS) should be chosen based on the regulation threshold V_{I_{REG}}, across this resistor.

$$R_{(SNS)} = \frac{V_{I_{REG}}}{I_{OCHARGE}} \tag{2}$$

APPLICATION INFORMATION

The value of $R_{(ISET1)}$ is then calculated based on the following equation:

$$I_{OPRECHG} = \frac{K_{(ISET1)} \times V_{(ISET1)}}{(R_{ISET1} \times R_{(SNS)})} \quad (3)$$

where

- $V_{(ISET1)}$ is the output of the ISET1 pin
- $K_{(ISET1)}$ is the output current set factor
- $V_{(ISET1)}$ and $K_{(ISET1)}$ are shown in the Electrical Characteristics table.

The following provide a more detailed design procedure and example for this parameter:

1. Select the charge current.

Example design:

- $I_{OCHARGE} = 2 \text{ A}$
- $I_{OPRECHG} = 200\text{mA}$

2. Select the sense resistor value. Ensure the power rating of the sense resistor is not exceeded

Example:

- Select $R_{(SNS)} = 0.050 \Omega$

$$V_{(SNS)} = R_{(SNS)} \times I_{OCHARGE} = 0.050 \Omega \times 2 \text{ A} = 0.1 \text{ V} \quad (4)$$

$$P_{(SNS)} = R_{(SNS)} \times (I_{OCHARGE})^2 = (0.050 \Omega \times 2 \text{ A})^2 = 0.2 \text{ W} \quad (5)$$

- Select 0805 or 1206 size rated at 0.25 W

3. Determine $R_{(ISET1)}$.

- $V_{(ISET1)} = 1 \text{ V}$
- $K_{(ISET1)} = 1000 \text{ V/A}$

$$R_{(ISET1)} = \frac{K_{(ISET1)} \times V_{(ISET1)}}{R_{(SNS)} \times I_{OCHARGE}} = \frac{1000 \text{ V/A} \times 0.1 \text{ V}}{0.050 \Omega \times 2 \text{ A}} = 10 \text{ k}\Omega \quad (6)$$

4. Determine $R_{(ISET2)}$

- $V_{(ISET2)} = 0.1 \text{ V}$
- $K_{(ISET2)} = 1000\text{V/A}$

$$R_{(ISET2)} = \frac{K_{(ISET2)} \times V_{(ISET2)}}{R_{(SNS)} \times I_{OPRECHG}} = \frac{1000 \text{ V/A} \times 0.1 \text{ V}}{0.050 \Omega \times 2 \text{ A}} = 10 \text{ k}\Omega \quad (7)$$

APPLICATION INFORMATION

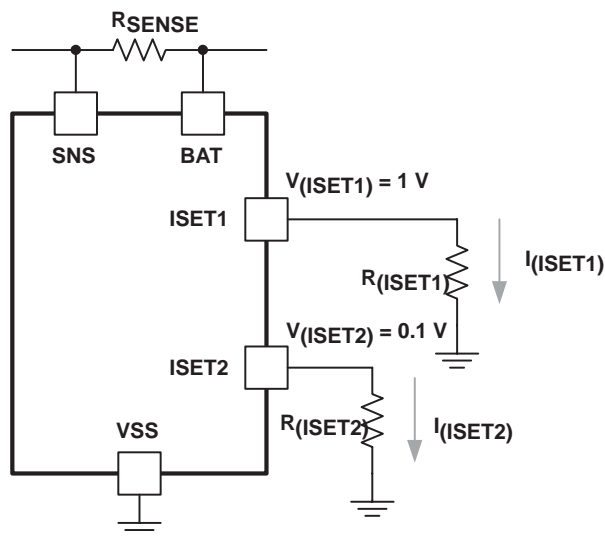

UDG-04036

Figure 8. Program Charge Current with R(ISET1) and R(ISET2)

Battery Voltage Regulation

The voltage regulation feedback occurs through the BAT pin. This input is tied directly to the positive side of the battery pack. The bqSWITCHER monitors the battery-pack voltage between the BAT and VSS pins. The bqSWITCHER is offered in two fixed-voltage versions; 4.2 V and 8.4 V as selected by the CELLS input. A low or floating input on the CELLS selects single cell (4.2 V) while a high-input selects two-cell mode.

For device options that include adjustable output voltage, the voltage regulation feedback is through the FB pin. A resistor divider is used from the battery output voltage to GND. BAT remains connected directly to the battery output voltage for current sensing with respect to SNS.

Charge Termination And Recharge

The bqSWITCHER monitors the charging current during the voltage regulation phase. Once the termination threshold, I_{TERM}, is detected the bqSWITCHER terminates charge. The termination current level is selected by the value of programming resistor, R(ISET2), connected to the ISET2 pin.

$$I_{TERM} = \frac{K_{(ISET2)} \times V_{TERM}}{(R_{(ISET2)} \times R_{(SNS)})} \tag{8}$$

where

- R_(SNS) is the external current sense resistor
- V_{TERM} is the output of the ISET2 pin
- K_(ISET2) is the output current set factor
- V_{TERM} and K_(ISET2) are specified in the Electrical Characteristics table

APPLICATION INFORMATION

As a safety backup, the bqSWITCHER also provides a programmable charge timer. The charge time is programmed by the value of resistor and capacitor connected to the TTC pin and by the following formula:

$$t_{\text{CHARGE}} = C_{(\text{TTC})} \times K_{(\text{TTC})} \quad (9)$$

where

- $C_{(\text{TTC})}$ is the capacitor connected to the TTC pin
- $K_{(\text{TTC})}$ is the multiplier

Charge timer can be disabled or reset by floating the TTC pin.

A new charge cycle is initiated when one of the following conditions are detected:

- The battery voltage falls below the V_{RCH} threshold
- Power-on reset (POR), if battery voltage is below the V_{RCH} threshold
- $\overline{\text{CE}}$ toggle
- TTC pin as described below

In order to disable the charge termination and safety timer, the user can pull the TTC input below the $V_{\text{TTC_EN}}$ threshold. Going above this threshold enables the termination and safety timer features and also reset the timer.

Sleep Mode

The bqSWITCHER enters the low-power sleep mode if the VCC pin is removed from the circuit. This feature prevents draining the battery during the absence of VCC.

Charge Status Outputs

The open-drain STAT1 and STAT2 outputs indicate various charger operations as shown in the following table. These status pins can be used to drive LEDs or communicate to the host processor. Note that OFF indicates the open-drain transistor is turned off.

Table 1. Status Pins Summary

Charge State	STAT1	STAT2
Battery absent ⁽¹⁾	OFF	OFF
Charge-in-progress	ON	OFF
Charge complete	OFF	ON
Charge suspend, timer fault, overvoltage or sleep mode	OFF	OFF

⁽¹⁾ Device is in battery-detection mode.

$\overline{\text{PG}}$ Output

The open-drain $\overline{\text{PG}}$ (powergood) indicates when the AC adapter (i.e. V_{CC}) is present. The output turns ON when sleep-mode exit threshold, $V_{\text{SLP_EXIT}}$, is detected. This output is turned off in the sleep mode. The $\overline{\text{PG}}$ pin can be used to drive an LED or communicate to the host processor.

$\overline{\text{CE}}$ Input (Charge Enable)

The $\overline{\text{CE}}$ digital input is used to disable or enable the charge process. A low-level signal on this pin enables the charge and a high-level signal disables the charge. A high-to-low transition on this pin also resets all timers and fault conditions. Note that the $\overline{\text{CE}}$ pin cannot be pulled up to VTSB voltage. This may create power-up issues.

APPLICATION INFORMATION

Battery Absent Detection

For applications with removable battery packs, bqSWITCHER provides a battery absent detection scheme to reliably detect insertion and/or removal of battery packs.

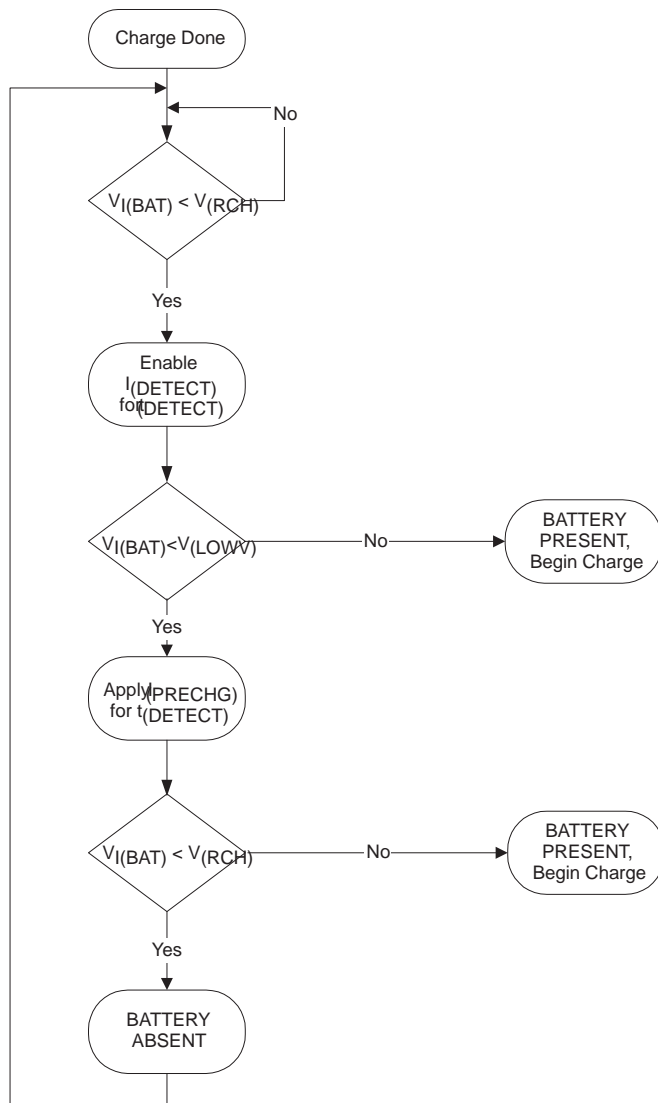

Figure 9. Battery Absent Detection

The voltage at the BAT pin is held above the battery recharge threshold, V_{RCH} , by the charged battery following fast charging. When the voltage at the BAT pin falls to the recharge threshold, either by a load on the battery or due to battery removal, the bqSWITCHER begins a battery absent detection test. This test involves enabling a detection current, I_{DETECT} , for a period of t_{DETECT} and checking to see if the battery voltage is below the pre-charge threshold, V_{LOWV} . Following this, the precharge current, $I_{OPRECHG}$ is applied for a period of t_{DETECT} and the battery voltage checked again to be above the recharge threshold. The purpose of this current is to attempt to close a battery pack with an open protector, if one is connected to the bqSWITCHER.

APPLICATION INFORMATION

Passing both of the discharge and charging tests indicates a battery absent fault at the STAT pins. Failure of either test starts a new charge cycle. For the absent battery condition the voltage on the BAT pin rises and falls between the V_{LOWV} and V_{OREG} thresholds indefinitely. (see Figure 7)

Timer Fault Recovery

As shown in Figure 5, bqSWITCHER provides a recovery method to deal with timer fault conditions. The following summarizes this method.

Condition #1

Charge voltage above recharge threshold (V_{RCH}) and timeout fault occurs.

Recovery method: bqSWITCHER waits for the battery voltage to fall below the recharge threshold. This could happen as a result of a load on the battery, self-discharge or battery removal. Once the battery falls below the recharge threshold, the bqSWITCHER clears the fault and enters the battery absent detection routine. A POR or \overline{CE} or \overline{TTE} toggle also clears the fault.

Condition #2

Charge voltage below recharge threshold (V_{RCH}) and timeout fault occurs

Recovery method: Under this scenario, the bqSWITCHER applies the I_{FAULT} current. This small current is used to detect a battery removal condition and remains on as long as the battery voltage stays below the recharge threshold. If the battery voltage goes above the recharge threshold, then the bqSWITCHER disables the I_{FAULT} current and executes the recovery method described for condition #1. Once the battery falls below the recharge threshold, the bqSWITCHER clears the fault and enters the battery absent detection routine. A POR or \overline{CE} toggle also clears the fault.

Output Overvoltage Protection (Applies To All Versions)

The bqSWITCHER provides a built-in overvoltage protection to protect the detect and other components against damages if the battery voltage gets too high, as when the battery is suddenly removed. When an overvoltage condition is detected, this feature turns off the PWM and STATx pins.

FUNCTIONAL DESCRIPTION FOR SYSTEM-CONTROLLED VERSION (bq2411x)

For applications requiring charge management under the host system control, the bqSWITCHER (bq2411x) offers a number of control functions. The following section describes these functions.

Precharge And Fast Charge Control

A low-level signal on the CMODE pin forces the bqSWITCHER to charge at the precharge rate set on the ISET2 pin. A high-level signal forces charge at fast charge rate as set by the ISET1 pin. If the battery reaches the voltage regulation level, V_{OREG} , the bqSWITCHER transitions to voltage regulation phase regardless of the status of the CMODE input.

Charge Termination And Safety Timers

The charge timers and termination are disabled in the system-controlled versions of the bqSWITCHER. The host system can use the \overline{CE} input to enable or disable charge. When an overvoltage condition is detected, the charger process stops, all power FETs are turned off.

APPLICATION INFORMATION

Inductor, Capacitor and Sense Resistor Selection Guidelines

The bqSWITCHER provides internal loop compensation. With this scheme, best stability occurs when LC resonant frequency, f_0 is approximately 16 kHz. Equation (10) can be used to calculate the value of the output inductor and capacitor. Table 2 provides a summary of typical component values for various charge rates.

$$f_0 = \frac{1}{2\pi \times \sqrt{L_{OUT} \times C_{OUT}}} \tag{10}$$

Table 2. Output Components Summary

CHARGE CURRENT	0.5 A	1 A	2 A
Output inductor, L_{OUT}	22 μ H	10 μ H	4.7 μ H
Output capacitor, C_{OUT}	4.7 μ F	10 μ F	22 μ F (or 2 \times 10 μ H) ceramic
Sense resistor, $R_{(SNS)}$	0.20 Ω	0.10 Ω	0.05 Ω

MECHANICAL DATA

RHL (R-PQFP-N20)

PLASTIC QUAD FLATPACK

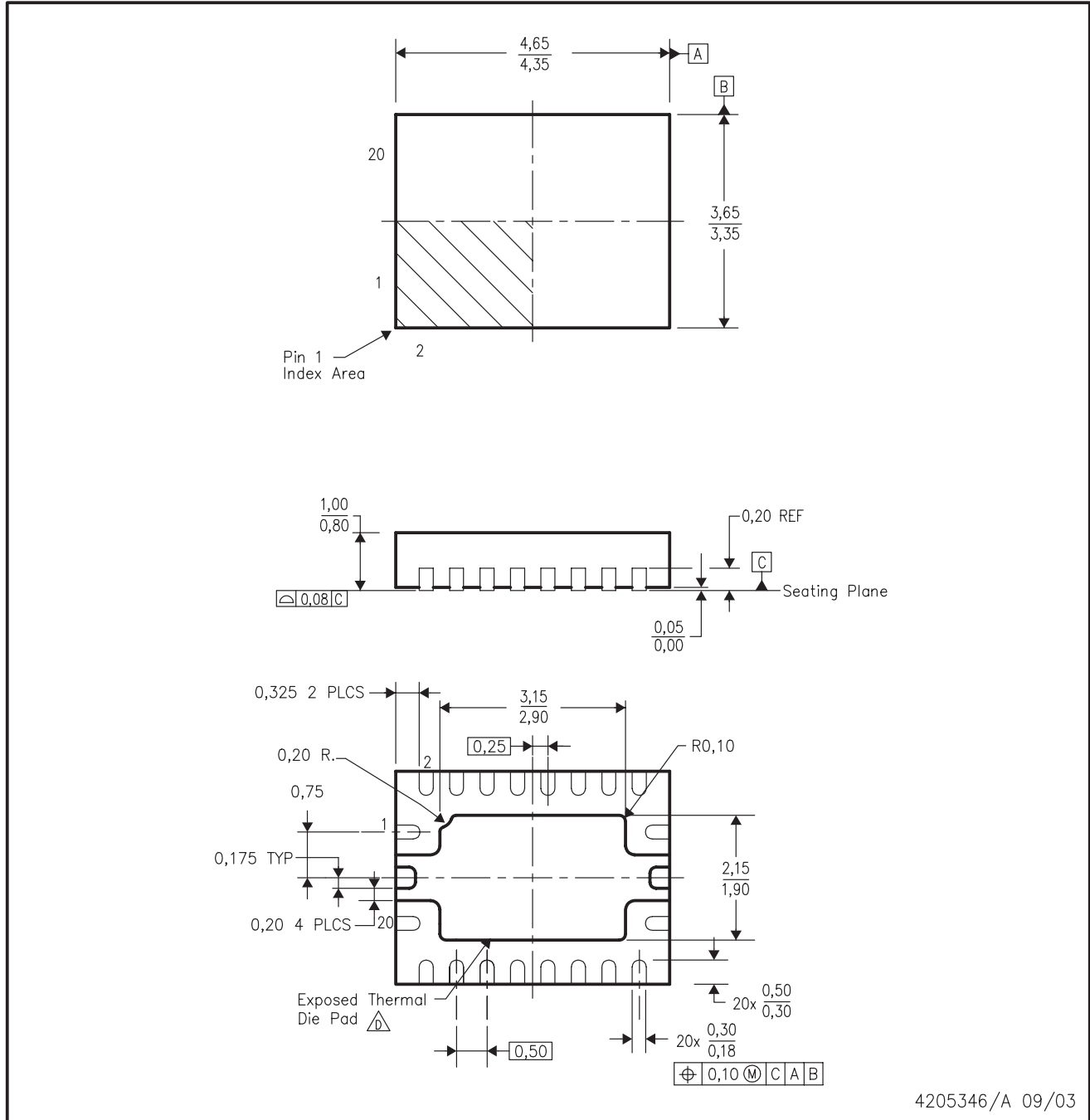

- NOTES:
- A. All linear dimensions are in millimeters.
 - B. This drawing is subject to change without notice.
 - C. QFN (Quad Flatpack No-Lead) Package configuration.
 - \triangle The Package thermal performance may be enhanced by bonding the thermal die pad to an external thermal plane. This pad is electrically and thermally connected to the backside of the die and possibly selected ground leads.

RHL (R-PQFP-N20)

PLASTIC QUAD FLATPACK

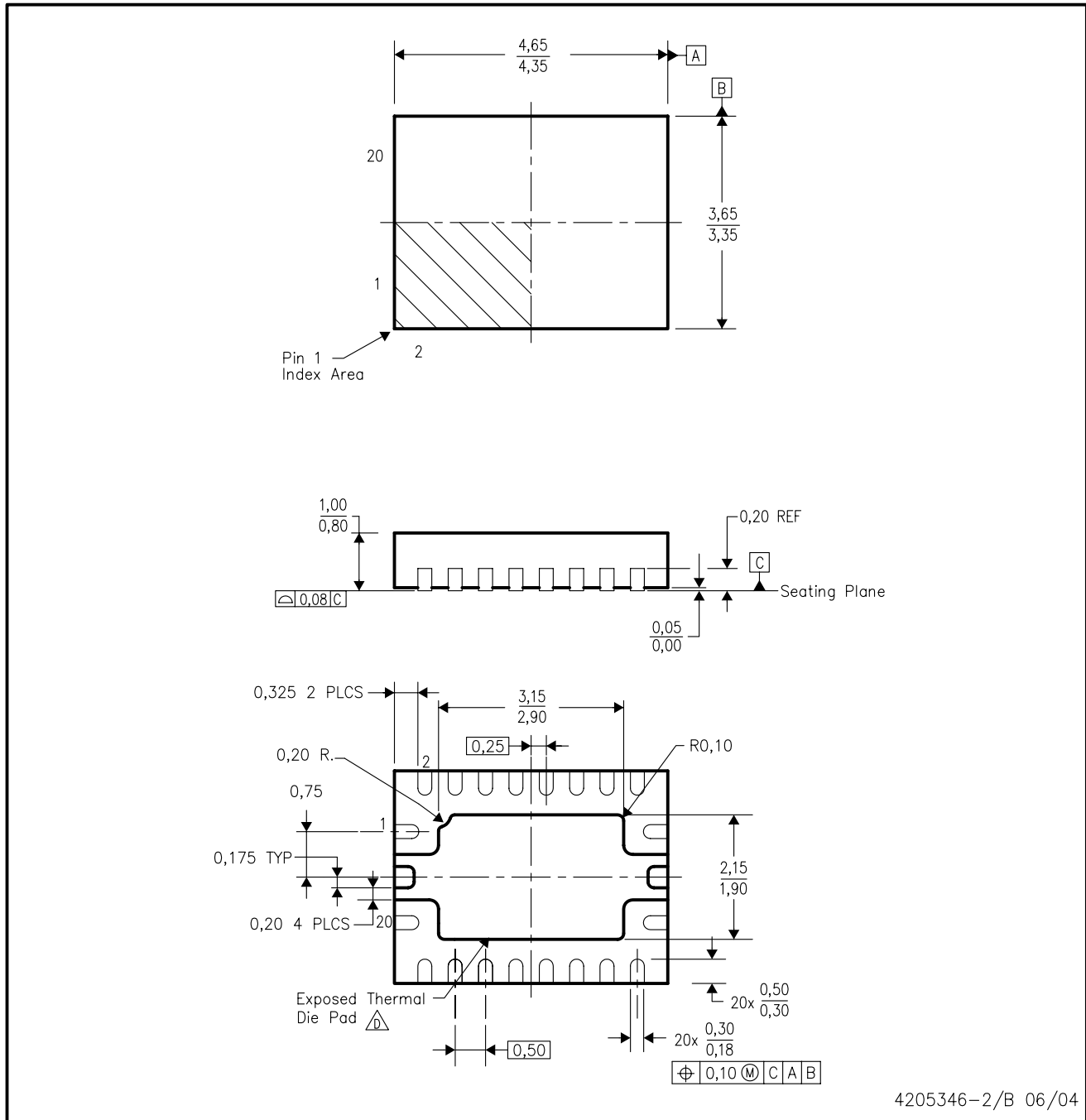

- NOTES:
- A. All linear dimensions are in millimeters.
 - B. This drawing is subject to change without notice.
 - C. QFN (Quad Flatpack No-Lead) Package configuration.
 - \triangle The Package thermal performance may be enhanced by bonding the thermal die pad to an external thermal plane. This pad is electrically and thermally connected to the backside of the die and possibly selected ground leads.

IMPORTANT NOTICE

Texas Instruments Incorporated and its subsidiaries (TI) reserve the right to make corrections, modifications, enhancements, improvements, and other changes to its products and services at any time and to discontinue any product or service without notice. Customers should obtain the latest relevant information before placing orders and should verify that such information is current and complete. All products are sold subject to TI's terms and conditions of sale supplied at the time of order acknowledgment.

TI warrants performance of its hardware products to the specifications applicable at the time of sale in accordance with TI's standard warranty. Testing and other quality control techniques are used to the extent TI deems necessary to support this warranty. Except where mandated by government requirements, testing of all parameters of each product is not necessarily performed.

TI assumes no liability for applications assistance or customer product design. Customers are responsible for their products and applications using TI components. To minimize the risks associated with customer products and applications, customers should provide adequate design and operating safeguards.

TI does not warrant or represent that any license, either express or implied, is granted under any TI patent right, copyright, mask work right, or other TI intellectual property right relating to any combination, machine, or process in which TI products or services are used. Information published by TI regarding third-party products or services does not constitute a license from TI to use such products or services or a warranty or endorsement thereof. Use of such information may require a license from a third party under the patents or other intellectual property of the third party, or a license from TI under the patents or other intellectual property of TI.

Reproduction of information in TI data books or data sheets is permissible only if reproduction is without alteration and is accompanied by all associated warranties, conditions, limitations, and notices. Reproduction of this information with alteration is an unfair and deceptive business practice. TI is not responsible or liable for such altered documentation.

Resale of TI products or services with statements different from or beyond the parameters stated by TI for that product or service voids all express and any implied warranties for the associated TI product or service and is an unfair and deceptive business practice. TI is not responsible or liable for any such statements.

Following are URLs where you can obtain information on other Texas Instruments products and application solutions:

Products		Applications	
Amplifiers	amplifier.ti.com	Audio	www.ti.com/audio
Data Converters	dataconverter.ti.com	Automotive	www.ti.com/automotive
DSP	dsp.ti.com	Broadband	www.ti.com/broadband
Interface	interface.ti.com	Digital Control	www.ti.com/digitalcontrol
Logic	logic.ti.com	Military	www.ti.com/military
Power Mgmt	power.ti.com	Optical Networking	www.ti.com/opticalnetwork
Microcontrollers	microcontroller.ti.com	Security	www.ti.com/security
		Telephony	www.ti.com/telephony
		Video & Imaging	www.ti.com/video
		Wireless	www.ti.com/wireless

Mailing Address: Texas Instruments
Post Office Box 655303 Dallas, Texas 75265