

NOTES

- MATERIALS:**
HOUSING -94V-0, GLASS-FILLED POLYESTER
TERMINAL-BERYLLIUM COPPER, POST-PLATED:
.000200/(0.00508) MINIMUM TIN/LEAD IN CONTACT AREA, .000075/(0.00191) MINIMUM TIN/LEAD IN TAIL AREA, OVER .000050/(0.00127) MINIMUM NICKEL OVERALL.
OR .000030/(0.00076) MINIMUM GOLD IN CONTACT AREA, .000075/(0.00191) MINIMUM TIN/LEAD IN TAIL AREA OVER .000050/(0.00127) MINIMUM NICKEL OVERALL.
- ASSEMBLIES TO BE SHIPPED IN TRAYS.
- DIMENSIONS GIVEN ACROSS CENTERLINES ARE SYMMETRICAL ABOUT THOSE CENTERLINES TO WITHIN HALF THE TOTAL TOLERANCE, EXCEPT 1.590 DIMENSION.
- THIS PART MATES WITH 78802-**** CARRIER.
- MINIMUM TERMINAL RETENTION: 1.0 LB./CIRCUIT.
- FOR POLARIZATION OPTIONS, SEE SHEET 2.
- PS-78804 APPLIES.

D	THIS WAS -110 ECN UDT1999-1005 SCHAFFER 99/06/18	
C	REVISED PER ECN#1478 MJS 5-24-96	
B	RELEASED ON CAD PER ECR #190175 09/23/88 PB/SEC	
MFG. SH.	REV.	LTR.
2	B	
1	D	

DIMENSIONS SHOWN (METRIC) INCH UNLESS OTHERWISE SPECIFIED TOLERANCES ANGULAR ± 1/2°		▽ = 0 ▼ = 0		REVISE ONLY ON CAD SYSTEM	
INCH METRIC		TITLE			
3 PLACE ± .005	---	SALES ASSEMBLY			
2 PLACE ± .01	± 0.13	28 CKT. MEMORY MODULE SOCKET			
1 PLACE ---	± 0.25	.100 x .600 GRID			
DRAFT WHERE APPLICABLE MUST REMAIN WITHIN DIMENSIONS		MOLEX INCORPORATED		SHEET NO. DATE	
PART NO. DRWG. NO.		1515E.ILL. 60532		1 OF 2 9/27/88	
DRWG. BY: PB		CHK'D. BY: SEC		SEE SHEET 2 SDA-78805-****	
APP'D. BY: ASW		SCALE: 2:1		THIS DRAWING CONTAINS INFORMATION THAT IS PROPRIETARY TO MOLEX INC. AND SHOULD NOT BE USED WITHOUT WRITTEN PERMISSION.	

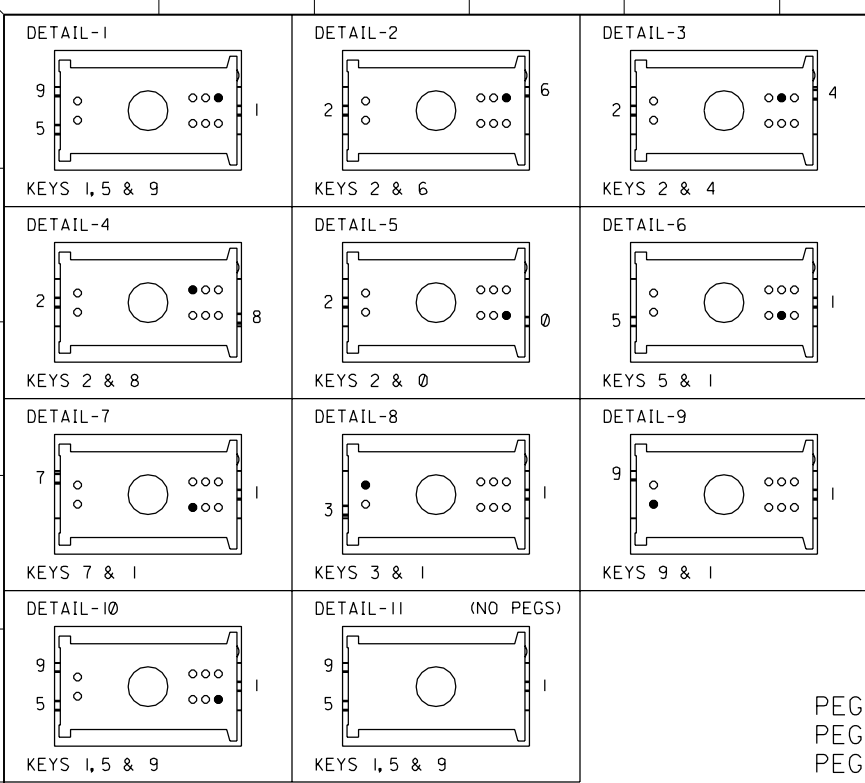

DETAIL		PLATING CODE	ENG. NO. A78805-	PART NO. (EDP)	DETAIL		PLATING CODE	ENG. NO. A78805-	PART NO. (EDP)
COLOR					COLOR				
RED	1	202	0436	15-29-2281					
YELLOW	3	202	0420	15-41-3283					
GRAY	4	202	0421	15-41-3284					
DK. GREEN	5	202	0422	15-41-3285					
NATURAL	6	202	0423	15-41-3286					
LT. BLUE	7	202	0424	15-41-3287					
ORANGE	8	202	0425	15-41-3288					
DK. BLUE	9	202	0426	15-41-3289					
BLACK	10	202	0418	15-41-3281					
BLACK	11	202	0518	15-29-9282					
BLACK	11	599	0918	15-41-2283					

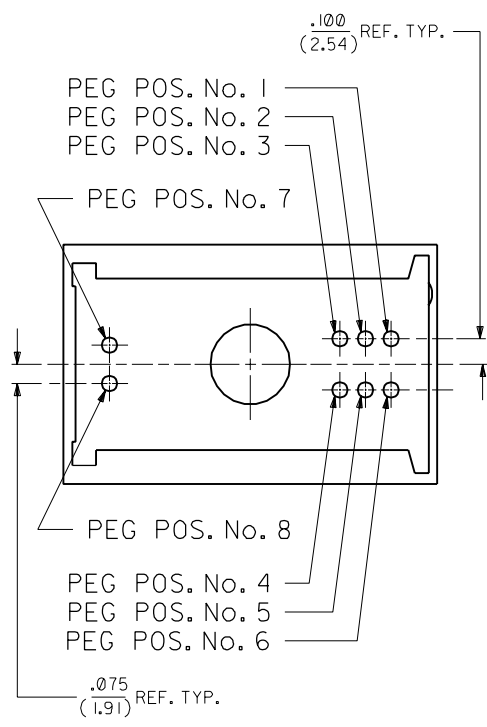

MFG. SH.	REV.	LTR.	REVISIONS
			SEE SHEET 1

DIMENSIONS SHOWN (METRIC) INCH		UNLESS OTHERWISE SPECIFIED TOLERANCES ANGULAR ± 1/2°		REVISIONS	
3 PLACE ± .005		INCH METRIC		TITLE	
2 PLACE ± .01 ± 0.13		---		SALES ASSEMBLY	
1 PLACE --- ± 0.25		---		28 CKT. MEMORY MODULE SOCKET	
DRAFT WHERE APPLICABLE MUST REMAIN WITHIN DIMENSIONS		MOLEX INCORPORATED		DATE	
DRWG. SEC		L15LEJLL 60532		9/27/88	
CHK'D. BY		U.S.A.		SHEET NO. 2	
SCALE 2:1		SEE CHART		SDA-78805-*****	
FILE NAME S0788052		THIS DRAWING CONTAINS INFORMATION THAT IS PROPRIETARY TO MOLEX INC. AND SHOULD NOT BE USED WITHOUT WRITTEN PERMISSION.		DIV. DA	

78805