

---

## Features

- Complies with Intel Low-Pin Count (LPC) Interface Specification Revision 1.1
  - Supports both Firmware Hub (FWH) and LPC Memory Read and Write Cycles
- Auto-detection of FWH and LPC Memory Cycles
  - Can Be Used as FWH for Intel 8xx, E7xxx, and E8xxx Series Chipsets
  - Can Be Used as LPC Flash for Non-Intel Chipsets
- Flexible, Optimized Sectoring for BIOS Applications
  - 32-Kbyte Top Boot Sector, Two 8-Kbyte Sectors, One 16-Kbyte Sector, Seven 64-Kbyte Sectors
  - Or Memory Array Can Be Divided Into Eight Uniform 64-Kbyte Sectors for Erasing
- Two Configurable Interfaces
  - FWH/LPC Interface for In-System Operation
  - Address/Address Multiplexed (A/A Mux) Interface for Programming during Manufacturing
- FWH/LPC Interface
  - Operates with the 33 MHz PCI Bus Clock
  - 5-signal Communication Interface Supporting Byte Reads and Writes
  - Two Hardware Write Protect Pins:  $\overline{\text{TBL}}$  for Top Boot Sector and  $\overline{\text{WP}}$  for All Other Sectors
  - Five General-purpose Input (GPI) Pins for System Design Flexibility
  - Identification (ID) Pins for Multiple Device Selection
  - Sector Locking Registers for Individual Sector Read and Write Protection
- A/A Mux Interface
  - 11-pin Multiplexed Address and 8-pin Data Interface
  - Facilitates Fast In-System or Out-of-System Programming
- Single Voltage Operation
  - 3.0V to 3.6V Supply Voltage for Read and Write Operations
- Industry-Standard Package Options
  - 32-lead PLCC
  - 40-lead TSOP
- Green (Pb/Halide-free) Packaging Option

## 1. Description

The AT49LH004 is a Flash memory device designed for use in PC and notebook BIOS applications. The device complies with version 1.1 of Intel's LPC Interface Specification, providing support for both FWH and LPC memory read and write cycles. The device can also automatically detect the memory cycle type to allow the AT49LH004 to be used as a FWH with Intel chipsets or as an LPC Flash with non-Intel chipsets.

The sectoring of the AT49LH004's memory array has been optimized to meet the needs of today's BIOS applications. By optimizing the size of the sectors, the BIOS code memory space can be used more efficiently. Because certain BIOS code modules must reside in their own sectors by themselves, the wasted and unused memory space that occurred with previous generation BIOS Flash memory devices can be greatly reduced. This increased memory space efficiency allows additional BIOS routines to be developed and added while still maintaining the same overall device density.



---

## 4-megabit Firmware Hub and Low-Pin Count Flash Memory

---

### AT49LH004



The memory array of the AT49LH004 can be sectored in two ways simply by using two different erase commands. Using one erase command allows the device to contain a total of 11 sectors comprised of a 32-Kbyte boot sector, two 8-Kbyte sectors, a 16-Kbyte sector, and seven 64-Kbyte sectors. The 32-Kbyte boot sector is located at the top (uppermost) of the device's memory address space. Alternatively, by using a different erase command, the memory array can be arranged into eight even erase sectors of 64-Kbyte each.

The AT49LH004 supports two hardware interfaces: The FWH/LPC interface for In-System operations and the A/A Mux interface for programming during manufacturing. The Interface Configuration (IC) pin of the device provides the control between these two interfaces. An internal Command User Interface (CUI) serves as the control center between the device interfaces and the internal operation of the nonvolatile memory. A valid command sequence written to the CUI initiates device automation.

Specifically designed for use in 3-volt systems, the AT49LH004 supports read, program, and erase operations with a supply voltage range of 3.0V to 3.6V. No separate voltage is required for programming and erasing.

The AT49LH004 utilizes fixed program and erase times, independent of the number of program and erase cycles that have occurred. Therefore, the system does not need to be calibrated or correlated to the cumulative number of program and erase cycles.

## 2. Pin Configurations

### 2.1 32-lead PLCC

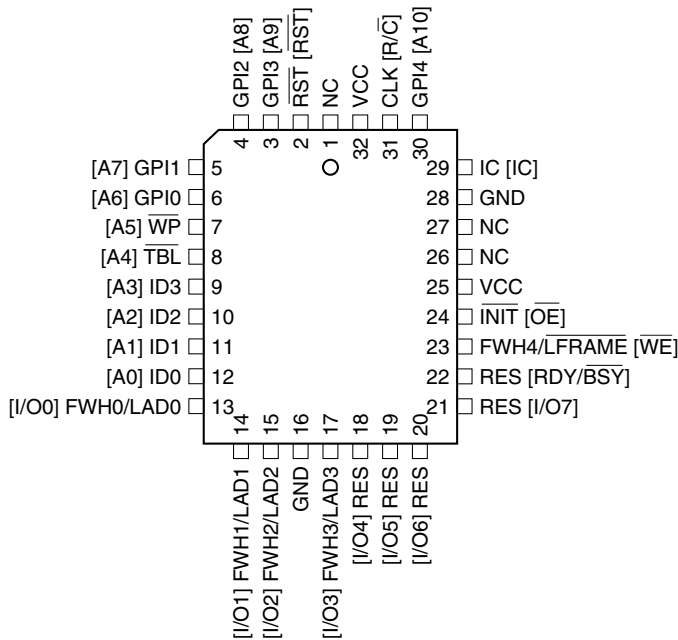

### 2.2 40-lead TSOP

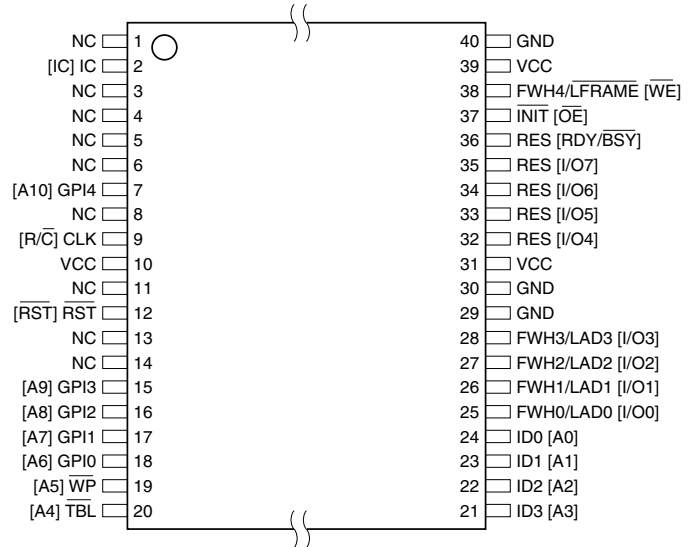

Note: [ ] Designates A/A Mux Interface.

### 3. Block Diagram

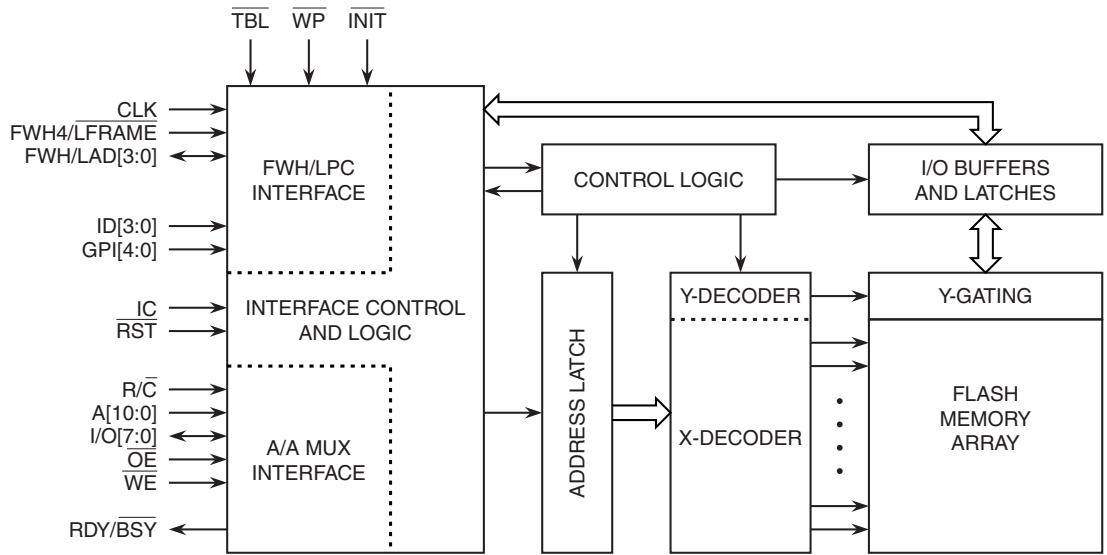

### 4. Device Memory Map

Sector	Type	Size (Bytes)	Address Range
10	Sub-sector	32K	078000H - 07FFFFH
9	Sub-sector	8K	076000H - 077FFFH
8	Sub-sector	8K	074000H - 075FFFH
7	Sub-sector	16K	070000H - 073FFFH
6	Main Sector	64K	060000H - 06FFFFH
5	Main Sector	64K	050000H - 05FFFFH
4	Main Sector	64K	040000H - 04FFFFH
3	Main Sector	64K	030000H - 03FFFFH
2	Main Sector	64K	020000H - 02FFFFH
1	Main Sector	64K	010000H - 01FFFFH
0	Main Sector	64K	000000H - 00FFFFH

## 5. Pin Description

Table 5-1 provides a description of each of the device pins. Most of the pins have dual functionality in that they are used for both the FWH/LPC interface as well as the A/A Mux interface.

Table 5-1. Signal Descriptions

Symbol	Name and Function	Interface		Type
		FWH/LPC	A/A Mux	
IC	<p><b>INTERFACE COMMUNICATION:</b> The IC pin determines which interface is operational. If the IC pin is held high, then the A/A Mux interface is enabled, and if the IC pin is held low, then the FWH/LPC interface is enabled. The IC pin must be set at power-up or before returning from a reset condition and cannot be changed during device operation.</p> <p>The IC pin is internally pulled-down with a resistor valued between 20 kΩ and 100 kΩ, so connection of this pin is not necessary if the FWH/LPC interface will always be used in the system. If the IC pin is driven high to enable the A/A Mux interface, then the pin will exhibit some leakage current.</p>	X	X	Input
CLK	<p><b>FWH/LPC CLOCK:</b> This pin is used to provide a clock to the device. This pin is usually connected to the 33 MHz PCI clock and adheres to the PCI specification.</p> <p><i>This pin is used as the <math>\overline{R/\overline{C}}</math> pin in the A/A Mux interface.</i></p>	X		Input
$\overline{\text{FWH4/LFRAME}}$	<p><b>FWH INPUT/LPC FRAME:</b> This pin is used to indicate the start of a FWH or LPC data transfer operation. The pin is also used to abort a FWH or LPC cycle in progress.</p> <p><i>This pin is used as the <math>\overline{\text{WE}}</math> pin in the A/A Mux interface.</i></p>	X		Input
$\overline{\text{FWH/LAD[3:0]}}$	<p><b>FWH/LPC ADDRESS AND DATA:</b> These pins are used for FWH/LPC bus information such as addresses, data, and command inputs/outputs.</p> <p><i>These pins are used as the I/O[3:0] pins in the A/A Mux interface.</i></p>	X		Input/Output
$\overline{\text{RST}}$	<p><b>INTERFACE RESET:</b> The <math>\overline{\text{RST}}</math> pin is used for both FWH/LPC and A/A Mux interfaces. When the <math>\overline{\text{RST}}</math> pin is driven low, write operations are inhibited, internal automation is reset, and the <math>\overline{\text{FWH/LAD[3:0]}}</math> pins (when using the FWH/LPC interface) are put into a high-impedance state. When the device exits the reset state, it will default to the read array mode.</p>	X	X	Input
$\overline{\text{INIT}}$	<p><b>PROCESSOR RESET/INITIALIZE:</b> The <math>\overline{\text{INIT}}</math> pin is used as a second reset pin for In-System operation and functions identically to the <math>\overline{\text{RST}}</math> pin. The <math>\overline{\text{INIT}}</math> pin is designed to be connected to the chipset's <math>\overline{\text{INIT}}</math> signal.</p> <p>The maximum voltage to be applied to the <math>\overline{\text{INIT}}</math> pin depends on the processor's or chipset's specifications. Systems must take care to not violate processor or chipset specifications regarding the <math>\overline{\text{INIT}}</math> pin voltage.</p> <p><i>This pin is used as the <math>\overline{\text{OE}}</math> pin in the A/A Mux interface.</i></p>	X		Input
$\overline{\text{TBL}}$	<p><b>TOP BOOT SECTOR LOCK:</b> When the <math>\overline{\text{TBL}}</math> pin is held low, program and erase operations cannot be performed to the top 64-Kbyte region (in FWH mode) or the top 32-Kbyte boot sector (in LPC mode) regardless of the state of the Sector Locking Registers. In addition, the <math>\overline{\text{TBL}}</math> pin will protect the uppermost 64-Kbyte region against erasures when using the LPC mode and the Uniform Sector Erase command. Please refer to the Sector Protection section for more details.</p> <p>If the <math>\overline{\text{TBL}}</math> pin is held high, then hardware write protection for the top boot sector will be disabled. However, register-based sector protection will still apply. The state of the <math>\overline{\text{TBL}}</math> pin does not affect the state of the Sector Locking Registers.</p> <p><i>This pin is used as the A4 pin in the A/A Mux interface.</i></p>	X		Input

Table 5-1. Signal Descriptions (Continued)

Symbol	Name and Function	Interface		Type
		FWH/LPC	A/A Mux	
$\overline{WP}$	<p><b>WRITE PROTECT:</b> The <math>\overline{WP}</math> pin is used to protect all remaining sectors that are not being used for the top boot region. See “Sector Protection” on page 17. for more details.</p> <p>If the <math>\overline{WP}</math> pin is high, then hardware write protection for all of the sectors except the top boot sector will be disabled. Register-based sector protection, however, will still apply. The state of the <math>\overline{WP}</math> pin does not affect the state of the Sector Locking Registers.</p> <p><i>This pin is used as the A5 pin in the A/A Mux interface.</i></p>	X		Input
ID[3:0]	<p><b>IDENTIFICATION INPUTS:</b> These four pins are part of the mechanism that allows multiple devices to be attached to the same bus. The strapping of these pins is used to assign an ID to each device. The boot device must have ID[3:0] = 0000, and it is recommended that all subsequent devices should use sequential up-count strapping (e.g., 0001, 0010, 0011, etc.).</p> <p>The ID[3:0] pins are internally pulled-down with resistors valued between 20 k<math>\Omega</math> and 100 k<math>\Omega</math> when using the FWH/LPC interface, so connection of these pins is not necessary if only a single device will be used in a system. Any pins intended to be low may be left floating. Any ID pin driven high will exhibit some leakage current.</p> <p><i>These pins are used as the A[3:0] pins in the A/A Mux interface.</i></p>	X		Input
GPI[4:0]	<p><b>GENERAL-PURPOSE INPUTS:</b> The individual GPI pins can be used for additional board flexibility. The state of the GPI pins can be read, using the FWH/LPC interface, through the GPI register. The GPI pins should be at their desired state before the start of the PCI clock cycle during which the read is attempted, and they should remain at the same level until the end of the read cycle.</p> <p>The voltages applied to the GPI pins must comply with the devices <math>V_{IH}</math> and <math>V_{IL}</math> requirements. Any unused GPI pins must not be left floating.</p> <p><i>These pins are used as the A[10:6] pins in the A/A Mux interface.</i></p>	X		Input
A[10:0]	<p><b>ADDRESS INPUTS:</b> These pins are used for inputting the multiplexed address values when using the A/A Mux interface. The addresses are latched by the rising and falling edge of <math>R/\overline{C}</math> pin.</p>		X	Input
I/O[7:0]	<p><b>DATA INPUTS/OUTPUTS:</b> The I/O pins are used in the A/A Mux interface to input data and commands during write cycles and to output data during memory array, Status Register, and identifier code read cycles. Data is internally latched during a write cycle.</p> <p>The I/O pins will be in a high-impedance state when the outputs are disabled.</p>		X	Input/ Output
$R/\overline{C}$	<p><b>ROW/COLUMN ADDRESS SELECT:</b> In the A/A Mux interface, the <math>R/\overline{C}</math> pin is used to latch the address values presented on the A[10:0] pins. The row addresses (A10 - 0) are latched on the falling edge of <math>R/\overline{C}</math>, and the column addresses (A18 - A11) are latched on the rising edge of <math>R/\overline{C}</math>.</p>		X	Input
$\overline{OE}$	<p><b>OUTPUT ENABLE:</b> The <math>\overline{OE}</math> pin is used in the A/A Mux interface to control the device’s output buffers during a read cycle.</p> <p>The I/O[7:0] pins will be in high-impedance state when the <math>\overline{OE}</math> pin is deasserted (high).</p>		X	Input
$\overline{WE}$	<p><b>WRITE ENABLE:</b> The <math>\overline{WE}</math> pin is used in the A/A Mux interface to control write operations to the device.</p>		X	Input

**Table 5-1.** Signal Descriptions (Continued)

Symbol	Name and Function	Interface		Type
		FWH/LPC	A/A Mux	
RDY/ $\overline{\text{BSY}}$	<b>READY/BUSY:</b> The RDY/ $\overline{\text{BSY}}$ pin provides the device's ready/busy status when using the A/A Mux interface. The RDY/ $\overline{\text{BSY}}$ pin is a reflection of Status Register bit 7, which is used to indicate whether a program or erase operation has been completed. Use of the RDY/ $\overline{\text{BSY}}$ pin is optional, and the pin does not need to be connected.		X	Output
VCC	<b>DEVICE POWER SUPPLY:</b> The VCC pin is used to supply the source voltage to the device. Program and erase operations are inhibited when $V_{\text{CC}}$ is less than or equal to $V_{\text{LKO}}$ . Operations at invalid $V_{\text{CC}}$ voltages may produce spurious results and should not be attempted.	X	X	Power
GND	<b>GROUND:</b> The ground reference for the power supply. GND should be connected to the system ground.	X	X	Power
NC	<b>NO CONNECT:</b> NC pins have no internal connections and can be driven or left floating. If the pins are driven, the voltage levels should comply with $V_{\text{IH}}$ and $V_{\text{IL}}$ requirements.	X	X	–
RES	<b>RESERVED:</b> RES pins are reserved for future device enhancements or functionality. These pins may be left floating or may be driven. If the pins are driven, the voltage levels should comply with $V_{\text{IH}}$ and $V_{\text{IL}}$ requirements. <i>These pins are used as the RDY/<math>\overline{\text{BSY}}</math> and I/O[7:4] pins in the A/A Mux interface.</i>	X	X	–

## 6. Interface Selection

The AT49LH004 can operate in two distinct interface modes: The FWH/LPC interface and the A/A Mux interface. Selection of the interface is determined by the state of the IC pin. When the IC pin is held low, the device will operate using the FWH/LPC interface. Alternatively, when the IC pin is held high, the device will operate using the A/A Mux interface.

## 7. FWH/LPC Interface

The FWH/LPC interface is designed as an In-System interface used in communicating with either the I/O Controller Hub (ICH) in Intel chipsets or typically the PCI south bridge in non-Intel chipsets.

The FWH/LPC interface uses a 5-signal communication interface consisting of a 4-bit data bus, the FWH/LAD[3:0] pins, and one control line, the FWH4/ $\overline{\text{LFRAME}}$  pin. The operation and timing of the interface is based on the 33 MHz PCI clock, and the buffers for the FWH/LPC interface are PCI compliant. To ensure the effective delivery of security and manageability features, the FWH/LPC interface is the only way to get access to the full feature set of the device.

Commands, addresses, and data are transferred via the FWH/LPC interface using a series of fields. The field sequences and contents are strictly defined for FWH and LPC memory cycles. These field sequences are detailed in the FWH Interface Operation and LPC Interface Operation sections.

Since the AT49LH004 can be used as either a FWH Flash or an LPC Flash, the device is capable of automatically detecting which type of memory cycle is being performed. For a FWH/LPC cycle, the host will drive the FWH4/LFRAME pin low for one or more clock cycles to initiate the operation. After driving the FWH4/LFRAME pin low, the host will send a START value to indicate the type of FWH/LPC cycle that is to be performed. The value of the START field determines whether the device will operate using a FWH cycle or an LPC cycle. [Table 7-1](#) details the three valid START fields that the device will recognize.

**Table 7-1.** FWH/LPC Start Fields

START Value	Cycle Type
0000b	LPC Cycle – The type (memory, I/O, DMA) and direction of the cycle (read or write) is determined by the second field (CYCTYPE + DIR) of the LPC cycle. Only memory cycles are supported by the device.
1101b	FWH Memory Read Cycle
1110b	FWH Memory Write Cycle

If a valid START value is not detected, then the device will enter standby mode when the FWH4/LFRAME pin is high and no internal operation is in progress. The FWH/LAD[3:0] pins will also be placed in a high-impedance state.

## 7.1 FWH4/LFRAME Pin

FWH4/LFRAME is used by the master to indicate the start of cycles and the termination of cycles due to an abort or time-out condition. This signal is to be used by peripherals to know when to monitor the bus for a cycle.

The FWH4/LFRAME signal is used as a general notification that the FWH/LAD[3:0] lines contain information relative to the start or stop of a cycle, and that peripherals must monitor the bus to determine whether the cycle is intended for them. The benefit to peripherals of FWH4/LFRAME is that it allows them to enter lower power states internally when a cycle is not intended for them.

When peripherals sample FWH4/LFRAME is active, they are to immediately stop driving the FWH/LAD[3:0] signal lines on the next clock and monitor the bus for new cycle information.

## 7.2 FWH/LAD[3:0] Pins

The FWH/LAD[3:0] signal lines communicate address, control, and data information over the LPC bus between a master and a peripheral. The information communicated are: start, stop (abort a cycle), transfer type (memory, I/O, DMA), transfer direction (read/write), address, data, wait states, DMA channel, and bus master grant.

## 7.3 FWH Memory Cycles

A valid FWH memory cycle begins with the host driving the  $\overline{\text{FWH4/LFRAME}}$  signal low for one or more clock cycles. While the  $\overline{\text{FWH4/LFRAME}}$  signal is low, a valid START value of either 1101b (FWH memory read) or 1110b (FWH memory write) must be driven on the FWH/LAD[3:0] pins. Following the START field, an IDSEL (Device Select) field must be sent to the device. The IDSEL field acts like a chip select in that it indicates which device should respond to the current operation. After the IDSEL field has been sent, the 7-clock MADDR (Memory Address) field must be sent to the device to provide the 28-bit starting address location of where to begin reading or writing in the memory. Following the MADDR field, the MSIZE (Memory Size) field must be sent to indicate the number of bytes to transfer.

**Figure 7-1.** FWH Memory Cycle Initiation and Addressing

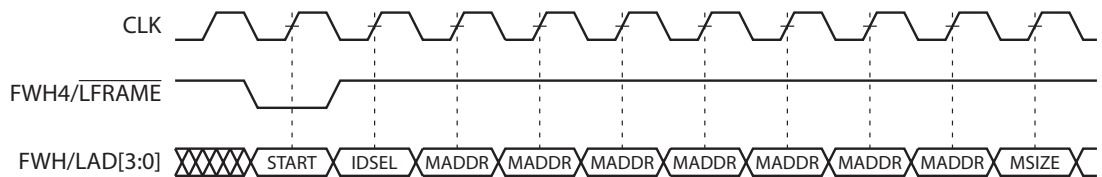

### 7.3.1 Start Field

This 1-clock field indicates the start of a cycle. It is valid on the last clock that  $\overline{\text{FWH4/LFRAME}}$  is sampled low. The two start fields that are used for a FWH cycle are: 1101b to indicate a FWH memory read cycle and 1110b to indicate a FWH memory write cycle. If the start field that is sampled is not one of these values, then the cycle attempted is not a FWH memory cycle. It may be a valid LPC memory cycle that the device will attempt to decode.

### 7.3.2 IDSEL (Device Select) Field

This 1-clock field is used to indicate which FWH component in the system is being selected. The four bits transmitted over FWH/LAD[3:0] during this clock are compared with values strapped on the ID[3:0] pins. If there is a match, the device will continue to decode the cycle to determine which bytes are requested on a read or which bytes to update on a write. If there isn't a match, the device may discard the rest of the cycle and go into a standby power state.

### 7.3.3 MADDR (Memory Address) Field

This is a 7-clock field that is used to provide a 28-bit (A27 - A0) memory address. This allows for provisioning of up to 256 MB per FWH memory device, for a total of a 4 GB addressable space if 16 FWH memory devices (256 MB each) were used in a system.

The AT49LH004 only decodes the last six MADDR nibbles (A23 - A0) and ignores address bits A27 - A23 and A21 - A19. Address bit A22 is used to determine whether reads or writes to the device will be directed to the memory array (A22 = 1) or to the register space (A22 = 0).

Addresses are transferred to the device with the most significant nibble first.

### 7.3.4 MSIZE (Memory Size) Field

The 1-clock MSIZE is used to indicate how many bytes of data will be transferred during a read or write. The AT49LH004 only supports single-byte transfers, so 0000b must be sent in this field to indicate a single-byte transfer.

**7.3.5 Additional Fields for FWH Memory Cycles**

Additional fields are required to complete a FWH read or write cycle. The placement of these fields, in addition to the data field, depends on whether the cycle is a FWH read or write. The FWH Read Cycle and FWH Write Cycle sections detail the order of the various fields.

**7.3.6 TAR (Turn-around) Field**

This 2-clock field is driven by the master when it is turning control over to the FWH memory device, and it is driven by the FWH device when it is turning control back over to the master. On the first clock of the TAR field, the master or FWH drives the FWH/LAD[3:0] lines to 1111b. On the second clock, the master or FWH device puts the FWH/LAD[3:0] lines into a high-impedance state.

**7.3.7 SYNC (Synchronize) Field**

This field is used to add wait-states for an access. It can be several clocks in length. On target cycles, this field is driven by the FWH memory device. If the FWH device needs to assert wait-states, it does so by driving a “wait” SYNC value of 0101b on the FWH/LAD[3:0] pins until it is ready. When ready, the device will drive a “ready” SYNC value of 0000b on the FWH/LAD[3:0] lines. Valid values for the SYNC field are shown in [Table 7-2](#).

**Table 7-2.** Valid SYNC Values

SYNC Value	SYNC Type
0000b	RSYNC (Ready SYNC) – Synchronization has been achieved with no error.
0101b	WSYNC (Wait SYNC) – Device is indicating wait-states (also referred to as short-sync).

**7.4 FWH Read Cycle**

FWH read cycles are used to read data from the memory array, the Sector Locking Registers, the GPI register, the Status Register, and to read the product ID information. Upon initial device power-up or after exiting from a reset condition, the device will automatically default to the read array mode.

Valid FWH read cycles begin with a START field of 1101b being sent to the device. Following the IDSEL, MADDR, and MSIZE fields, a 2-clock TAR field must be sent to the device to indicate that the master is turning control of the LPC bus over to the FWH memory device. After the second clock of the TAR phase, the FWH device assumes control of the bus and begins driving SYNC fields to add wait-states. When the device is ready to output data, it will first send a “ready” SYNC and then output one byte of data during the next two clock cycles. The data is sent one nibble at a time with the low nibble being output first followed by the high nibble. After the data has been output, the FWH device will send a 2-clock TAR field to the master to indicate that it is turning control of the LPC bus back over to the master.

[Table 7-2](#) shows a FWH read cycle that requires three SYNC clocks to access data from the memory array.

**Figure 7-2. FWH Read Cycle**

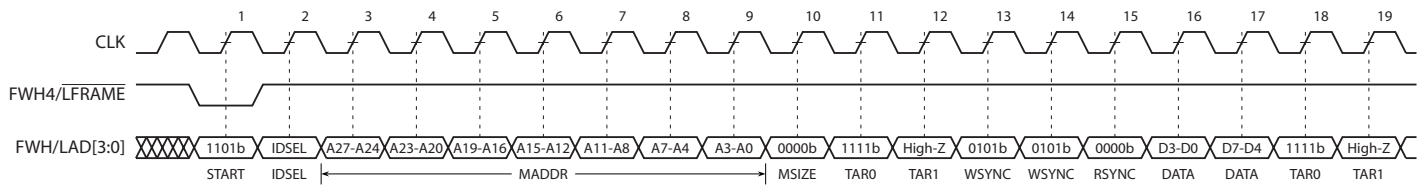

**Table 7-3. FWH Read Cycle**

Clock Cycle	Field Name	Field Value <sup>(1)</sup> FWH/LAD[3:0]	FWH/LAD[3:0] Direction	Comments
1	START	1101b	IN	FWH4/LFRAME must be active (low) for the device to respond. Only the last START field (before FWH4/LFRAME transitioning high) should be recognized. The START field contents indicate a FWH memory read cycle.
2	IDSEL	0000b to 1111b	IN	Indicates which FWH memory device should respond. If the IDSEL field matches the strapping values on ID[3:0], then that particular device will respond to subsequent commands.
3 - 9	MADDR	YYYY	IN	These seven clock cycles make up the 28-bit memory address. YYYY is one nibble of the entire address. Addresses are transferred with the most significant nibble first.
10	MSIZE	0000b (indicates 1 byte)	IN	The MSIZE field indicates how many bytes will be transferred. The device only supports single-byte operations, so MSIZE must be 0000b.
11	TAR0	1111b	IN then float	In this clock cycle, the master has driven the bus to all 1s and then floats the bus prior to the next clock cycle. This is the first part of the bus “turn-around cycle”.
12	TAR1	1111b (float)	Float then OUT	The device takes control of the bus during this clock cycle.
13 - 14	WSYNC	0101b (wait)	OUT	The device outputs the value 0101b, a “wait” SYNC, for two clock cycles. This value indicates to the master that data is not yet available from the device. This number of wait-syncs is a function of the device’s memory access time.
15	RSYNC	0000b (ready)	OUT	During this clock cycle, the device will generate a “ready” SYNC indicating that the least significant nibble of the data byte will be available during the next clock cycle.
16	DATA	YYYY	OUT	YYYY is the least significant nibble of the data byte.
17	DATA	YYYY	OUT	YYYY is the most significant nibble of the data byte.
18	TAR0	1111b	OUT then float	The FWH memory device drives the bus to 1111b to indicate a turn-around cycle.
19	TAR1	1111b (float)	Float then IN	The FWH memory device floats its outputs, and the master regains control of the bus during this clock cycle.

Note: 1. Field contents are valid on the rising edge of the present clock cycle.

## 7.5 FWH Write Cycle

FWH write cycles are used to send commands to the device and to program data into the memory array.

Valid FWH write cycles begin with a START field of 1110b being sent to the device. Following the IDSEL, MADDR, and MSIZE fields, the master sends one byte of data to the FWH device during the next two clock cycles. The data is sent one nibble at a time with the low nibble being output first followed by the high nibble. After the data has been sent, the master will send a 2-clock TAR field to the FWH device to indicate that it is turning control of the LPC bus back over to the FWH. After the second clock of the TAR phase, the FWH device assumes control of the bus and drives a “ready” SYNC field to verify that it has received the data. The FWH device will then send a 2-clock TAR field to the master to indicate that it is turning control of the bus back over to the master.

Figure 7-3. FWH Write Cycle

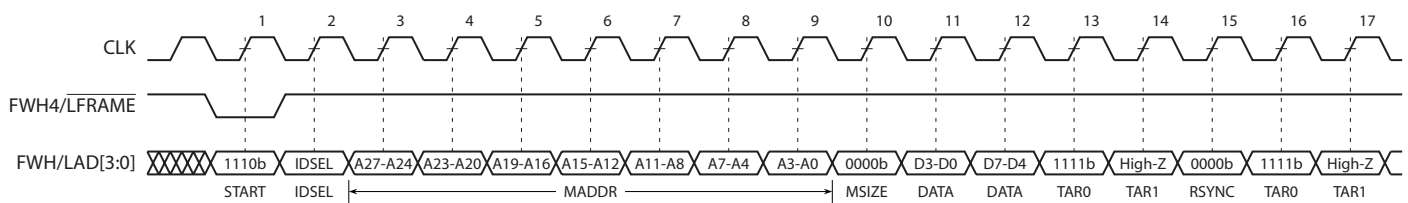

Table 7-4. FWH Write Cycle

Clock Cycle	Field Name	Field Value <sup>(1)</sup> FWH/LAD[3:0]	FWH/LAD[3:0] Direction	Comments
1	START	1110b	IN	FWH4/LFRAME must be active (low) for the device to respond. Only the last START field (before FWH4/LFRAME transitioning high) should be recognized. The START field contents indicate a FWH memory write cycle.
2	IDSEL	0000b to 1111b	IN	Indicates which FWH memory device should respond. If the IDSEL field matches the strapping values on ID[3:0], then that particular device will respond to subsequent commands.
3 - 9	MADDR	YYYY	IN	These seven clock cycles make up the 28-bit memory address. YYYY is one nibble of the entire address. Addresses are transferred with the most significant nibble first.
10	MSIZE	0000b (indicates 1 byte)	IN	The MSIZE field indicates how many bytes will be transferred. The device only supports single-byte operations, so MSIZE must be 0000b.
11	DATA	YYYY	IN	YYYY is the least significant nibble of the data byte. The data byte is either any valid Flash command or the data to be programmed into the memory array.
12	DATA	YYYY	IN	YYYY is the most significant nibble of the data byte.
13	TAR0	1111b	IN then float	In this clock cycle, the master has driven the bus to all 1s and then floats the bus prior to the next clock cycle. This is the first part of the bus “turn-around cycle”.
14	TAR1	1111b (float)	Float then OUT	The device takes control of the bus during this clock cycle.
15	RSYNC	0000b (ready)	OUT	During this clock cycle, the device will generate a “ready” SYNC indicating that the data byte has been received.
16	TAR0	1111b	OUT then float	The FWH memory device drives the bus to 1111b to indicate a turn-around cycle.
17	TAR1	1111b (float)	Float then IN	The FWH memory device floats its outputs, and the master regains control of the bus during this clock cycle.

Note: 1. Field contents are valid on the rising edge of the present clock cycle.

## 7.6 LPC Memory Cycles

A valid LPC memory cycle begins with the host driving the FWH4/ $\overline{\text{LFRAME}}$  signal low for one or more clock cycles. While the FWH4/ $\overline{\text{LFRAME}}$  signal is low, a valid START value of 0000b must be driven on the FWH/LAD[3:0] pins. Following the START field, a CYCTYPE + DIR (Cycle Type and Direction) field must be sent to the device to indicate the type of cycle (e.g., memory access, I/O access, etc.) and the direction (read or write) of the transfer. After the CYCTYPE + DIR field has been sent, the 8-clock MADDR (Memory Address) field must be sent to the device to provide the 32-bit starting address location of where to begin reading or writing in the memory.

**Figure 7-4.** LPC Memory Cycle Initiation and Addressing

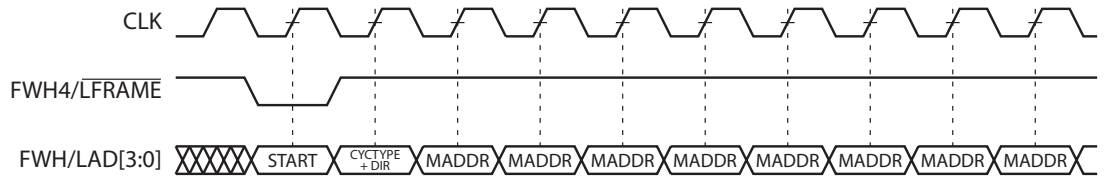

### 7.6.1 Start Field

This 1-clock field indicates the start of a cycle. It is valid on the last clock that FWH4/ $\overline{\text{LFRAME}}$  is sampled low. The start field that is used for an LPC cycle is 0000b. If the start field that is sampled is not 0000b, then the cycle attempted is not an LPC memory cycle. It may be a valid FWH memory cycle that the device will attempt to decode.

### 7.6.2 CYCTYPE + DIR (Cycle Type And Direction) Field

This 1-clock field is used to indicate the type of cycle and the direction of the transfer to be performed. Of the four bits placed on the FWH/LAD[3:0] pins, bits[3:2] must be 01b to indicate that the transfer will be a memory cycle. Values other than 01b, which may be used to specify an I/O cycle or a DMA cycle for other components in the system, will cause the device to enter standby mode when the FWH4/ $\overline{\text{LFRAME}}$  pin is brought high and no internal operation is in progress. The FWH/LAD[3:0] pins will also be placed in a high-impedance state.

Bit[1] is used to determine the direction of the transfer. 0 is used to indicate a read, and 1 is used to indicate a write. Bit[0] is ignored and reserved for future use. [Table 7-5](#) details the two valid CYCTYPE + DIR fields that the device will respond to.

**Table 7-5.** Valid CYCTYPE + DIR Values

FWH/LAD[3:0]	Cycle Type
010xb	LPC Memory Read
011xb	LPC Memory Write

**7.6.3 MADDR (Memory Address) Field**

This is an 8-clock field that is used to provide a 32-bit (A31 - A0) memory address. The 32 address bits allow for the provisioning to access up to 4 GB of memory space.

The AT49LH004 only decodes the last six MADDR nibbles (A23 - A0) and ignores address bits A31 - A24. Address bit A23 is used to determine whether reads or writes to the device will be directed to the memory array (A23 = 1) or to the register space (A23 = 0).

Unlike FWH memory cycles, LPC cycles do not use an IDSEL field to determine which LPC device in the system is being selected. Instead, the strapping values on the ID[3:0] pins are compared against address bits A22 - A19 in the MADDR field. For the actual comparison, the strapped values are internally inverted. For example, if ID3 was strapped to GND, a logical value of 1 would be compared against address bit A22. If the inverted states of the ID[3:0] pins match with address bits A22 - A19, then the device will continue to decode the rest of cycle (see LPC Multiple Device Selection for mode details).

Addresses are transferred to the device with the most significant nibble first.

**7.6.4 Additional Fields for LPC Memory Cycles**

Additional fields are required to complete an LPC read or write cycle. The placement of these fields, in addition to the data field, depends on whether the cycle is an LPC read or write. The LPC Read Cycle and LPC Write Cycle sections detail the order of the various fields.

**7.6.5 TAR (Turn-around) Field**

This 2-clock field is driven by the master when it is turning control over to the LPC memory device, and it is driven by the LPC device when it is turning control back over to the master. On the first clock of the TAR field, the master or LPC device drives the FWH/LAD[3:0] lines to 1111b. On the second clock, the master or LPC device puts the FWH/LAD[3:0] lines into a high-impedance state.

**7.6.6 SYNC (Synchronize) Field**

This field is used to add wait-states for an access. It can be several clocks in length. On target cycles, this field is driven by the LPC memory device. If the LPC device needs to assert wait-states, it does so by driving a “wait” SYNC value of 0101b on the FWH/LAD[3:0] pins until it is ready. When ready, the device will drive a “ready” SYNC value of 0000b on the FWH/LAD[3:0] lines. Valid values for the SYNC field are shown in [Table 7-6](#).

**Table 7-6.** Valid SYNC Values

SYNC Value	SYNC Type
0000b	RSYNC (Ready SYNC) – Synchronization has been achieved with no error.
0101b	WSYNC (Wait SYNC) – Device is indicating wait-states (also referred to as short-sync).

**7.7 LPC Read Cycle**

LPC read cycles are used to read data from the memory array, the Sector Locking Registers, the GPI register, the Status Register, and the product ID information. Upon initial device power-up or after exiting from a reset condition, the device will automatically default to the read array mode.

Valid LPC read cycles begin with a START field of 0000b and a CYCTYPE + DIR field of 010xb being sent to the device. Following the MADDR field, a 2-clock TAR field must be sent

to the device to indicate that the master is turning control of the LPC bus over to the LPC memory device. After the second clock of the TAR phase, the LPC device assumes control of the bus and begins driving SYNC fields to add wait-states. When the device is ready to output data, it will first send a “ready” SYNC and then output one byte of data during the next two clock cycles. The data is sent one nibble at a time with the low nibble being output first followed by the high nibble. After the data has been output, the LPC device will send a 2-clock TAR field to the master to indicate that it is turning control of the LPC bus back over to the master.

Figure 7-5 shows a LPC read cycle that requires three SYNC clocks to access data from the memory array.

**Figure 7-5.** LPC Read Cycle

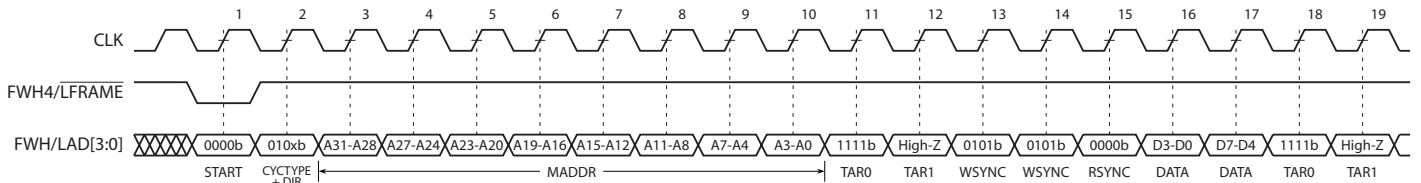

**Table 7-7.** LPC Read Cycle

Clock Cycle	Field Name	Field Value <sup>(1)</sup> FWH/LAD[3:0]	FWH/LAD[3:0] Direction	Comments
1	START	0000b	IN	FWH4/LFRAME must be active (low) for the device to respond. Only the last START field (before FWH4/LFRAME transitioning high) should be recognized. The START field contents indicate an LPC cycle.
2	CYCTYPE + DIR	010xb	IN	Indicates that the cycle type is an LPC memory cycle and the direction of the transfer is a read.
3 - 10	MADDR	YYYY	IN	These eight clock cycles make up the 32-bit memory address. YYYY is one nibble of the entire address. Addresses are transferred with the most significant nibble first.
11	TAR0	1111b	IN then float	In this clock cycle, the master has driven the bus to all 1s and then floats the bus prior to the next clock cycle. This is the first part of the bus “turn-around cycle”.
12	TAR1	1111b (float)	Float then OUT	The device takes control of the bus during this clock cycle.
13 - 14	WSYNC	0101b (wait)	OUT	The device outputs the value 0101b, a “wait” SYNC, for two clock cycles. This value indicates to the master that data is not yet available from the device. This number of wait-syncs is a function of the device’s memory access time.
15	RSYNC	0000b (ready)	OUT	During this clock cycle, the device will generate a “ready” SYNC indicating that the least significant nibble of the data byte will be available during the next clock cycle.
16	DATA	YYYY	OUT	YYYY is the least significant nibble of the data byte.
17	DATA	YYYY	OUT	YYYY is the most significant nibble of the data byte.
18	TAR0	1111b	OUT then float	The LPC memory device drives the bus to 1111b to indicate a turn-around cycle.
19	TAR1	1111b (float)	Float then IN	The LPC memory device floats its outputs, and the master regains control of the bus during this clock cycle.

Note: 1. Field contents are valid on the rising edge of the present clock cycle.

## 7.8 LPC Write Cycle

LPC write cycles are used to send commands to the device and to program data into the memory array.

Valid LPC write cycles begin with a START field of 0000b and a CYCTYPE + DIR field of 011xb being sent to the device. Following the MADDR field, the master sends one byte of data to the LPC device during the next two clock cycles. The data is sent one nibble at a time with the low nibble being output first followed by the high nibble. After the data has been sent, the master will send a 2-clock TAR field to the LPC device to indicate that it is turning control of the bus back over to the LPC device. After the second clock of the TAR phase, the LPC device assumes control of the bus and drives a “ready” SYNC field to verify that it has received the data. The LPC device will then send a 2-clock TAR field to the master to indicate that it is turning control of the bus back over to the master.

Figure 7-6. LPC Write Cycle

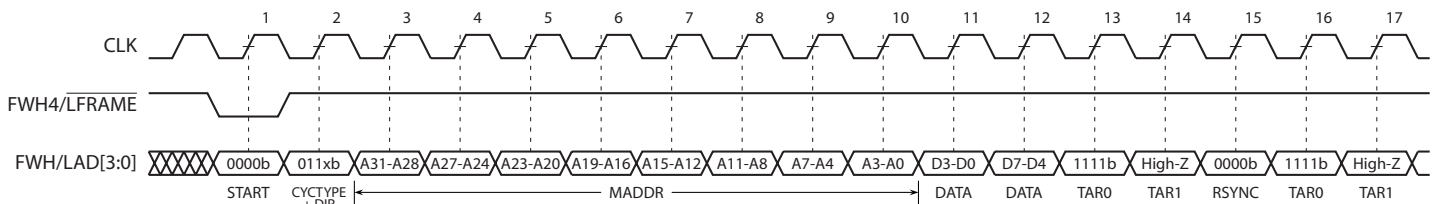

Table 7-8. LPC Write Cycle

Clock Cycle	Field Name	Field Value <sup>(1)</sup> FWH/LAD[3:0]	FWH/LAD[3:0] Direction	Comments
1	START	0000b	IN	FWH4/LFRAME must be active (low) for the device to respond. Only the last START field (before FWH4/LFRAME transitioning high) should be recognized. The START field contents indicate an LPC cycle.
2	CYCTYPE + DIR	011xb	IN	Indicates that the cycle type is an LPC memory cycle and the direction of the transfer is a write.
3 - 10	MADDR	YYYY	IN	These eight clock cycles make up the 32-bit memory address. YYYY is one nibble of the entire address. Addresses are transferred with the most significant nibble first.
11	DATA	YYYY	IN	YYYY is the least significant nibble of the data byte. The data byte is either any valid Flash command or the data to be programmed into the memory array.
12	DATA	YYYY	IN	YYYY is the most significant nibble of the data byte.
13	TAR0	1111b	IN then float	In this clock cycle, the master has driven the bus to all 1s and then floats the bus prior to the next clock cycle. This is the first part of the bus “turn-around cycle”.
14	TAR1	1111b (float)	Float then OUT	The device takes control of the bus during this clock cycle.
15	RSYNC	0000b (ready)	OUT	During this clock cycle, the device will generate a “ready” SYNC indicating that the data byte has been received.
16	TAR0	1111b	OUT then float	The LPC memory device drives the bus to 1111b to indicate a turn-around cycle.
17	TAR1	1111b (float)	Float then IN	The LPC memory device floats its outputs, and the master regains control of the bus during this clock cycle.

Note: 1. Field contents are valid on the rising edge of the present clock cycle.

## 8. Response to Invalid FWH/LPC Fields

During FWH/LPC operations, the device will not explicitly indicate that it has received invalid field sequences. The response to specific invalid fields or sequences is outlined in the following paragraphs.

### 8.1 FWH Cycles

#### 8.1.1 ID Mismatch

If the IDSEL field does not match ID[3:0], then the device will ignore the FWH cycle. The device will then enter standby mode when the FWH4/ $\overline{\text{LFRAME}}$  pin is brought high and no internal operation is in progress. The FWH/LAD[3:0] pins will also be placed in a high-impedance state.

#### 8.1.2 Address Out of Range

The FWH address sequences is seven fields long (28 bits), but only the last six address fields (A23 - A0) will be decoded. Therefore, address bits A27 - A24 will be ignored. In addition, because of the device density, address bits A23 and A21 - A19 will be ignored. Address bit A22 is used to determine whether reads or writes to the device will be directed to the memory array (A22 = 1) or to the register space (A22 = 0).

#### 8.1.3 Invalid MSIZE Field

If the device receives an invalid size field during a read or write operation, the internal state machine will reset and no operation will be attempted. The device will generate no response of any kind in this situation. Invalid size fields for a read or write cycle are anything but 0000b. In addition, when accessing register space, invalid field sizes are anything but 0000b.

Once valid START, IDSEL, and MSIZE fields are received, the device will always respond to subsequent inputs as if they were valid. As long as the states of FWH/LAD[3:0] and FWH4/ $\overline{\text{LFRAME}}$  are known, the response of the device to signals received during the FWH cycle should be predictable. The device will make no attempt to check the validity of incoming Flash operation commands.

### 8.2 LPC Cycles

#### 8.2.1 Address Out of Range

The LPC address sequences is eight fields long (32 bits), but only the last six address fields (A23 - A0) will be decoded. Therefore, address bits A31 - A24 will be ignored. Address bits A22 - A19 will be decoded based on the strapping values on the ID[3:0] pins. Address bit A23 is used to determine whether reads or writes to the device will be directed to the memory array (A23 = 1) or to the register space (A23 = 0).

Once valid START and CYCTYPE + DIR fields are received, the device will always respond to subsequent inputs as if they were valid. As long as the states of FWH/LAD[3:0] and FWH4/ $\overline{\text{LFRAME}}$  are known, the response of the device to signals received during the LPC cycle should be predictable. The device will make no attempt to check the validity of incoming Flash operation commands.

## 9. Bus Abort

The Bus Abort operation can be used to immediately abort the current bus operation. A Bus Abort occurs when FWH4/ $\overline{\text{LFRAME}}$  is driven low for one or more clock cycles after the start of a bus cycle. The memory will place the FWH/LAD[3:0] pins in a high-impedance state, and the internal state machine will reset. During a write cycle, there is the possibility that an internal Flash write or erase operation may be in progress (or has just been initiated). If the FWH4/ $\overline{\text{LFRAME}}$  pin is asserted during this time frame, the internal operation will not abort. However, the internal state machine will not initiate a Flash write or erase operation until it has received the last nibble from the host. This means that FWH4/ $\overline{\text{LFRAME}}$  can be asserted as late as clock cycle 12 (see Table 7-4 and Table 7-8) and no internal Flash operation will be attempted.

When the FWH4/ $\overline{\text{LFRAME}}$  pin has been driven low to abort a cycle, the host may issue a START field of 1111b (stop/abort) to return the interface to the ready mode.

## 10. Device Reset

Asserting  $\overline{\text{RST}}$  or  $\overline{\text{INIT}}$  initiates a device reset. In read mode,  $\overline{\text{RST}}$  or  $\overline{\text{INIT}}$  low deselects the memory, places the output drivers in a high-impedance state, and turns off all internal circuits.  $\overline{\text{RST}}$  or  $\overline{\text{INIT}}$  must be held low for the minimum specified  $t_{\text{PLPH}}$  time (FWH/LPC and A/A Mux operations). The device resets to read array mode upon return from reset, and all Sector Locking Registers are reset to their default (write-locked) state. Since all Sector Locking Registers are reset, all sectors in the memory array are set to the write-locked status regardless of their locked state prior to reset.

A reset recovery time ( $t_{\text{PHFV}}$  using the FWH/LPC interface and  $t_{\text{PHAV}}$  using the A/A Mux interface) is required from  $\overline{\text{RST}}$  or  $\overline{\text{INIT}}$  switching back high until writes to the CUI are recognized. A reset latency will occur if a reset procedure is performed during a programming or erase operation.

During sector erase or program, driving  $\overline{\text{RST}}$  or  $\overline{\text{INIT}}$  low will abort the operation underway in addition to causing a reset latency. Memory contents being altered are no longer valid since the data may be partially erased or programmed.

It is important to assert  $\overline{\text{RST}}$  or  $\overline{\text{INIT}}$  during system reset. When the system comes out of reset, it will expect to read from the memory array of the device. If a system reset occurs with no FWH/LPC device reset (this will be hardware dependent), it is possible that proper CPU initialization will not occur (the FWH/LPC memory may be providing status information instead of memory array data).

## 11. Sector Protection

Sectors in the memory array can be protected from program and erase operations using a hardware controlled method and/or a software (register-based) controlled method.

### 11.1 Hardware Write Protection

Two pins are available to provide hardware write protection capabilities. The Top Boot Sector Lock ( $\overline{\text{TBL}}$ ) pin, when held low, prevents program and sector erase operations to the top sector of the device (sector 10) where critical code can be stored. When operating in FWH mode, the  $\overline{\text{TBL}}$  pin is also used to protect sectors 9, 8, and 7 against program and erase operations. In addition, when operating in LPC mode, the  $\overline{\text{TBL}}$  pin has the flexibility to provide erase



protection to the top 64-Kbyte region (sectors 10, 9, 8, and 7) of the device when using the Uniform Sector Erase command. This allows the  $\overline{\text{TBL}}$  pin to protect a larger region for systems that require a 64-Kbyte top boot sector rather than a 32-Kbyte top boot sector.

When the  $\overline{\text{TBL}}$  pin is high, hardware write protection for program and erase operations to the top 64-Kbyte region (in FWH mode) or the top 32-Kbyte boot sector (in LPC mode) is disabled. Provided that the Write-Lock bits in the Sector Locking Registers are not set (detailed later), sector erase or program commands can then be issued to the device to program or erase these regions. In addition, in LPC mode, the entire top 64-Kbyte region (sectors 10, 9, 8, and 7) can be erased if using the Uniform Sector Erase command.

The Write Protect ( $\overline{\text{WP}}$ ) pin, which operates independently from the  $\overline{\text{TBL}}$  pin, serves the same basic function as the  $\overline{\text{TBL}}$  pin for the remaining sectors except the top boot sector (in LPC mode) or the top 64-Kbyte region (in FWH mode). When the  $\overline{\text{WP}}$  pin is held low in LPC mode, program and standard Sector Erase command operations to sectors 9 through 0 will not be allowed. If using the Uniform Sector Erase command, then erase operations to sectors 6 through 0 cannot be performed, and erase protection for sectors 10 through 7 will be controlled by the  $\overline{\text{TBL}}$  pin. In FWH mode, the  $\overline{\text{WP}}$  pin will always protect sectors 6 through 0 against both erase and program operations.

The  $\overline{\text{TBL}}$  and  $\overline{\text{WP}}$  pins must be set to the desired protection state prior to starting a program or erase operation because they are sampled at the beginning of the operation. Changing the state of  $\overline{\text{TBL}}$  or  $\overline{\text{WP}}$  during a program or erase operation may cause unpredictable results. The new lock status will take place after the program or erase operation completes.

**Table 11-1.** Hardware Write Protection Options

Sector	Size (Bytes)	Address Range	Hardware Write Protection		
			FWH Mode	LPC Mode	
			For All Program and Erase Commands	For the Following Commands: Sector Erase (21H) Byte Program (40H or 10H)	For the Following Command: Uniform Sector Erase (20H)
10	32K	078000H - 07FFFFH	$\overline{\text{TBL}}$	$\overline{\text{TBL}}$	$\overline{\text{TBL}}$
9	8K	076000H - 077FFFH	$\overline{\text{TBL}}$	$\overline{\text{WP}}$	$\overline{\text{TBL}}$
8	8K	074000H - 075FFFH	$\overline{\text{TBL}}$	$\overline{\text{WP}}$	$\overline{\text{TBL}}$
7	16K	070000H - 073FFFH	$\overline{\text{TBL}}$	$\overline{\text{WP}}$	$\overline{\text{TBL}}$
6	64K	060000H - 06FFFFH	$\overline{\text{WP}}$	$\overline{\text{WP}}$	$\overline{\text{WP}}$
5	64K	050000H - 05FFFFH	$\overline{\text{WP}}$	$\overline{\text{WP}}$	$\overline{\text{WP}}$
4	64K	040000H - 04FFFFH	$\overline{\text{WP}}$	$\overline{\text{WP}}$	$\overline{\text{WP}}$
3	64K	030000H - 03FFFFH	$\overline{\text{WP}}$	$\overline{\text{WP}}$	$\overline{\text{WP}}$
2	64K	020000H - 02FFFFH	$\overline{\text{WP}}$	$\overline{\text{WP}}$	$\overline{\text{WP}}$
1	64K	010000H - 01FFFFH	$\overline{\text{WP}}$	$\overline{\text{WP}}$	$\overline{\text{WP}}$
0	64K	000000H - 00FFFFH	$\overline{\text{WP}}$	$\overline{\text{WP}}$	$\overline{\text{WP}}$

The  $\overline{\text{TBL}}$  and  $\overline{\text{WP}}$  pins function independently from the Sector Locking Registers. These pins, when active, will write protect the appropriate sector(s) against program and erase operations regardless of the values of the Sector Locking Registers. For example, when  $\overline{\text{TBL}}$  is active, writing to the top sector is prevented regardless of the state of the Write-Lock bit for the top sector's locking register. In such a case, clearing the Write-Lock bit in the Sector Locking Register will have no functional effect even though the register may indicate that the sector is no longer locked. However, the register may still be set to Read-Lock the sector if desired.

For protecting the sectors of the memory array, the  $\overline{\text{TBL}}$  and  $\overline{\text{WP}}$  pins always take precedence over the Sector Locking Registers. In addition, the states of the  $\overline{\text{TBL}}$  and  $\overline{\text{WP}}$  pins have no effect on the values or status of the Sector Locking Registers.

## 11.2 Register-Based Sector Locking

The device has eight Sector Locking Registers in FWH mode and 11 Sector Locking Registers in LPC mode that are used in lieu of or in conjunction with the  $\overline{\text{TBL}}$  and  $\overline{\text{WP}}$  pins to control the lock protection for each sector in the memory array. The Sector Locking Registers are accessed through their respective address locations (detailed in Table 11-2) in the 4 GB system memory map. Since the address bit used to distinguish between memory and register accesses differs when the device is used as a FWH or LPC Flash (A22 for FWH and A23 for LPC), the register memory address will also differ.

The Sector Locking Registers are both readable and writable, and each register has three dedicated locking bits to control Read Lock, Write Lock, and Lock Down functions. Therefore, a Sector Locking Register can be read to determine what its current value is set to (e.g., set to Lock Down status). Reading the Sector Locking Registers, however, will not determine the status of the  $\overline{\text{TBL}}$  and  $\overline{\text{WP}}$  pins.

When returning from a reset condition or after power-up, the Sector Locking Registers will always default to a state of 01H.

**Table 11-2.** Sector Locking Registers

Register Name	Associated Sector	Sector Size (Bytes)	Register Memory Address		Default Value
			FWH MODE	LPC MODE	
S10_LK <sup>(1)</sup>	10	32K	FFBF0002H	FF7F8002H	01H
S9_LK <sup>(1)</sup>	9	8K		FF7F6002H	01H
S8_LK <sup>(1)</sup>	8	8K		FF7F4002H	01H
S7_LK <sup>(1)</sup>	7	16K		FF7F0002H	01H
S6_LK	6	64K	FFBE0002H	FF7E0002H	01H
S5_LK	5	64K	FFBD0002H	FF7D0002H	01H
S4_LK	4	64K	FFBC0002H	FF7C0002H	01H
S3_LK	3	64K	FFBB0002H	FF7B0002H	01H
S2_LK	2	64K	FFBA0002H	FF7A0002H	01H
S1_LK	1	64K	FFB90002H	FF790002H	01H
S0_LK	0	64K	FFB80002H	FF780002H	01H

Note: 1. In FWH mode, these registers are treated as one; therefore, only one Sector Locking Register is available for all sub-sectors (sectors 10, 9, 8, and 7) and the sub-sectors cannot be individually protected. The default value for this register is 01H.

### 11.2.1 Read Lock

The default read status of all sectors upon power-up is read-unlocked. When a sector's Read-Lock bit is set (1 state), data cannot be read from that sector. An attempted read from a read-locked sector will result in data 00H being read (note that a read failure is not reflected in the Status Register). The read lock status can be unlocked by clearing (0 state) the Read-Lock bit, provided that the Lock-Down bit has not been set. The current read lock status of a particular sector can be determined by reading the corresponding Read-Lock bit.

### 11.2.2 Write Lock

The default write status of all sectors upon power-up is write-locked (1 state). Any program or erase operations attempted on a locked sector will return an error in the Status Register (indicating sector lock). The status of the locked sector can be changed to unlocked (0 state) by clearing the Write-Lock bit, provided that the Lock-Down bit is not set. The current write lock status of a particular sector can be determined by reading the corresponding Write-Lock bit.

The Write-Lock bit must be set to the desired protection state prior to starting a program or erase operation because it is sampled at the beginning of the operation. Changing the state of the Write-Lock bit during a program or erase operation may cause unpredictable results. The new lock status will take place after the program or erase operation completes.

The write lock functions independently of the hardware write protect pins,  $\overline{\text{TBL}}$  and  $\overline{\text{WP}}$ . When active, these pins take precedence over the register-based write lock function. Changing the state of the  $\overline{\text{TBL}}$  and  $\overline{\text{WP}}$  pins will not affect the state of the Write-Lock bits. Reading the Sector Locking Registers will not read the state of the  $\overline{\text{TBL}}$  or  $\overline{\text{WP}}$  pins.

### 11.2.3 Lock Down

When in the FWH/LPC interface mode, the default lock down status of all sectors upon power-up is not-locked-down (0 state). The Lock-Down bit for any sector may be set (1 state), but only once, as future attempted changes to that Sector Locking Register will be ignored. Once a sector's Lock-Down bit is set, the Read-Lock and Write-Lock bits for that sector can no longer be modified, and the sector is locked down in its current state of read and write accessibility. The Lock-Down bit is only cleared upon a device reset with  $\overline{\text{RST}}$  or  $\overline{\text{INIT}}$  or after a power-up. The current lock down status of a particular sector can be determined by reading the corresponding Lock-Down bit.

**Table 11-3.** Function of Sector Locking Bits

Bit	Name	Description
7:3	Reserved	Reserved for future use.
2	Read-Lock	0 <b>Sector is not read-locked.</b> Normal read operations in the sector can occur. This is the default state.
		1 <b>Sector is read-locked.</b> Read operations within the sector are prevented. Data read will be 00H.
1	Lock-Down	0 <b>Sector is not locked down.</b> The Read-Lock and Write-Lock bits may be changed. This is the default state.
		1 <b>Sector is locked down.</b> The Read-Lock and Write-Lock bits cannot be changed. Once the sector is locked down, it will remain locked down until the device is reset (using the $\overline{RST}$ or $\overline{INIT}$ signals) or power-cycled.
0	Write-Lock	0 <b>Sector is not write-locked.</b> Normal program and erase operations to the sector can occur.
		1 <b>Sector is write-locked.</b> Program and erase operations to the sector are prevented. This is the default state.

**Table 11-4.** Valid Sector Locking Register Values

Data	Resulting Sector State
07H	Sector is read and write locked down.
06H	Sector is read locked down.
05H	Sector is read and write locked but not locked down.
04H	Sector is read locked but not locked down.
03H	Sector is write locked down.
02H	Sector is locked open (full access locked down).
01H	Sector is write locked but not locked down. This is the default state.
00H	Sector is open for full access.

## 12. General Purpose Input Register

A General-purpose Input Register is provided to read the status of the GPI[4:0] pins when using the FWH/LPC interface. Since this is a pass-through register, there is no default value. It is recommended that the GPI[4:0] pins be in their desired state before FWH4/LFRAME is brought low for the beginning of the next bus cycle and remain in that state until the end of the cycle.

**Table 12-1.** GPI Register Memory Address

Register Name	Associated Pins	Register Memory Address		Register Type
		FWH Mode	LPC Mode	
GPI_REG	GPI[4:0]	FFBC0100H	FF7C0100H	Read Only

**Table 12-2.** General-purpose Input Register

Bit	Name	Description	
7:5	Reserved	Reserved for future use.	
4	GPI_REG4	0	GPI4 input pin is at $V_{IL}$ .
		1	GPI4 input pin is at $V_{IH}$ .
3	GPI_REG3	0	GPI3 input pin is at $V_{IL}$ .
		1	GPI3 input pin is at $V_{IH}$ .
2	GPI_REG2	0	GPI2 input pin is at $V_{IL}$ .
		1	GPI2 input pin is at $V_{IH}$ .
1	GPI_REG1	0	GPI1 input pin is at $V_{IL}$ .
		1	GPI1 input pin is at $V_{IH}$ .
0	GPI_REG0	0	GPI0 input pin is at $V_{IL}$ .
		1	GPI0 input pin is at $V_{IH}$ .

## 13. Multiple Device Selection

Multiple devices may be used in a system to increase the overall memory density. By using the four ID strapping pins, ID[3:0], up to 16 devices may be attached to the same bus. BIOS support, bus loading, or the attaching bridge may limit the actual number of devices that can be connected to the bus.

The boot device must have ID[3:0] equal to 0000b, and all subsequent devices should use sequential up-count strapping.

**13.1 FWH Multiple Device Selection**

The strapping values on ID[3:0] must match the values in the IDSEL field when performing FWH memory cycles. The device will compare the values on the ID[3:0] pins with the IDSEL field. If there is a mismatch, the device will ignore the remainder of the cycle. The device will then enter standby mode when the FWH4/LFRAME pin is high and no internal operation is in progress. The FWH/LAD[3:0] pins will also be placed in a high-impedance state.

**Table 13-1. FWH Multiple Device Selection**

Device	ID Strapping Pins				IDSEL
	ID3	ID2	ID1	ID0	
0 (Boot Device)	0	0	0	0	0000b
1	0	0	0	1	0001b
2	0	0	1	0	0010b
3	0	0	1	1	0011b
4	0	1	0	0	0100b
5	0	1	0	1	0101b
6	0	1	1	0	0110b
7	0	1	1	1	0111b
8	1	0	0	0	1000b
9	1	0	0	1	1001b
10	1	0	1	0	1010b
11	1	0	1	1	1011b
12	1	1	0	0	1100b
13	1	1	0	1	1101b
14	1	1	1	0	1110b
15	1	1	1	1	1111b

## 13.2 LPC Multiple Device Selection

For LPC memory cycles, the inverse state of the strapping values on the ID[3:0] pins are compared against address bits A22 - A19 to determine if the device should respond. If there is a mismatch, the device will ignore the remainder of the cycle. The device will then enter standby mode when the FWH4/LFRAME pin is high and no internal operation is in progress. The FWH/LAD[3:0] pins will also be placed in a high-impedance state.

**Table 13-2.** LPC Multiple Device Selection

Device	ID Strapping Pins				Address Bits A22-A19
	ID3	ID2	ID1	ID0	
0 (Boot Device)	0	0	0	0	1111b
1	0	0	0	1	1110b
2	0	0	1	0	1101b
3	0	0	1	1	1100b
4	0	1	0	0	1011b
5	0	1	0	1	1010b
6	0	1	1	0	1001b
7	0	1	1	1	1000b
8	1	0	0	0	0111b
9	1	0	0	1	0110b
10	1	0	1	0	0101b
11	1	0	1	1	0100b
12	1	1	0	0	0011b
13	1	1	0	1	0010b
14	1	1	1	0	0001b
15	1	1	1	1	0000b

## 14. A/A Mux Interface

The A/A Mux interface is designed as a programming interface for OEMs to use during motherboard manufacturing or component pre-programming. The term A/A Mux refers to the multiplexed row and column addresses that this interface utilizes. The A/A Mux interface dramatically reduces the amount of overhead needed to access the device, allowing the device to be tested and programmed quickly with automated test equipment (ATE) and PROM programmers in the OEM's manufacturing flow. The number of signals required to use the interface does not change with device density; therefore, the interface can accommodate larger density devices while still allowing the device to fit into low lead-count packages.

Only basic read, erase, and program operations can be performed through the A/A Mux interface; FWH/LPC features, such as the use of the Sector Locking Registers and the General-purpose Input Register, are not available.

The A/A Mux interface mode is selected by driving the IC control pin high. The IC pin is internally pulled down in the device, so a modest amount of leakage current should be expected to be drawn (see DC Specifications) when the pin is driven high.

Four control pins dictate the flow of data into and out of the device:  $\overline{R/C}$ ,  $\overline{OE}$ ,  $\overline{WE}$ , and  $\overline{RST}$ . The  $\overline{R/C}$  pin is the A/A Mux interface control pin used to latch row and column addresses.  $\overline{OE}$  is the data output control pin for the I/O[7:0] lines and, when active, drives the selected memory data onto the I/O bus ( $\overline{WE}$  and  $\overline{RST}$  must be at  $V_{IH}$ ). The  $\overline{WE}$  pin controls the flow of data into the device. Addresses previously captured by the  $\overline{R/C}$  pin transitions and data are latched into the device on the rising edge of  $\overline{WE}$ . The  $\overline{RST}$  pin is used to reset the device.

## 14.1 Bus Operation

All A/A Mux bus cycles can be conformed to operate on most automated test equipment and PROM programmers.

**Table 14-1.** A/A Mux Interface Bus Operations

Mode	$\overline{RST}$	$\overline{OE}$	$\overline{WE}$	Address	I/O[7:0]
Read <sup>(1)(2)</sup>	$V_{IH}$	$V_{IL}$	$V_{IH}$	X	$D_{OUT}$
Output Disable <sup>(1)(2)</sup>	$V_{IH}$	$V_{IH}$	$V_{IH}$	X	High-Z
Write <sup>(1)(2)</sup>	$V_{IH}$	$V_{IH}$	$V_{IL}$	X	$D_{IN}$
Product ID Read <sup>(1)(2)(3)</sup>	$V_{IH}$	$V_{IL}$	$V_{IH}$	Note 3	Note 3

- Notes:
1. X can be  $V_{IL}$  or  $V_{IH}$  for control and address input pins.
  2.  $V_{IH}$  and  $V_{IL}$  refer to the DC characteristics associated with the Flash memory output buffers:  $V_{IL\ min} = 0.5V$ ,  $V_{IL\ max} = 0.8V$ ,  $V_{IH\ min} = 2.0V$ ,  $V_{IH\ max} = V_{CC} + 0.5V$ .
  3. Refer to [Table 16-2](#) for Product ID addresses and data.

## 14.2 Output Disable/Enable

With  $\overline{OE}$  at a logic-high level ( $V_{IH}$ ), the device outputs are disabled. Output pins I/O[7:0] are placed in the high-impedance state. With  $\overline{OE}$  at a logic-low level ( $V_{IL}$ ), the device outputs are enabled. Output pins I/O[7:0] are placed in an output-drive state.

## 14.3 Row/Column Addresses

$\overline{R/C}$  is the A/A Mux interface control pin used to latch row (A10 - A0) and column address (A18 - A11) values presented on the A[10:0] pins.  $\overline{R/C}$  latches row addresses on the falling edge and column addresses on the rising edge.

## 14.4 RDY/ $\overline{BSY}$

The open-drain Ready/Busy output pin provides a hardware method of detecting the end of a program or erase operation.  $\overline{RDY/BSY}$  is actively pulled low during the internal program and erase cycles and is released at the completion of the cycle.

## 15. Device Operation

The FWH/LPC and A/A Mux interfaces should be considered hardware interfaces that can be used to transfer commands and data to and from the device. The device commands detailed in “[Command Definitions Table](#)” on [page 26](#) can be issued using either interface.

Since the FWH/LPC interface communicates using a 4-bit data bus and the A/A Mux interface utilizes an 8-bit data bus, the number of interface bus cycles needed to perform an operation will vary. For example, when using the FWH/LPC interface, 17 PCI clock cycles are required for a FWH or LPC memory write cycle. Therefore, for one “write” device command cycle, 17 FWH/LPC bus cycles are needed. Likewise, for one “read” device command cycle using the FWH/LPC interface, 19 FWH/LPC bus cycles are required.

## 16. Command Definitions Table

Command	Command Cycles	1st Command Cycle			2nd Command Cycle		
		Type	Address	Data	Type	Address	Data
Read Array	1+	Write	Any Address	FFH	Read	Any Address	Data OUT
Sector Erase <sup>(1)(2)</sup>	2	Write	Any Address in the Sector	21H	Write	Any Address in the Sector	D0H
Uniform Sector Erase <sup>(1)(2)</sup>	2	Write	Any Address in the Sector	20H	Write	Any Address in the Sector	D0H
Byte Program <sup>(1)(3)</sup>	2	Write	The Address to be Programmed	40H or 10H	Write	The Address to be Programmed	Data IN
Read Status Register	2	Write	Any Address	70H	Read	Any Address	Status Register Data
Clear Status Register	1	Write	Any Address	50H			
Product ID Read <sup>(4)</sup>	2	Write	Any Address	90H	Read	ID Address	ID Data

- Notes:
1. The sector must not be hardware write protected or write-locked when attempting sector erase or program operations. Attempts to issue a sector erase or byte program command to a hardware write protected or write-locked sector will fail.
  2. Sub-sectors are sectors 10, 9, 8, and 7; the main sectors are sectors 6 through 0. Refer to the Device Memory Map and [Table 11-1](#) for sector sizes and address ranges. The Uniform Sector Erase command can be used to erase all sub-sectors at one time to allow uniform 64-Kbyte sectors to be erased. A Uniform Sector Erase command issued to any address in any one of the sub-sectors will cause all the sub-sectors to be erased provided that all of the sub-sectors are not protected or write-locked. The standard Sector Erase command can be used to individually erase both the sub-sectors and the main sectors, allowing a single erase command to be used to erase any sector in the memory array.
  3. Either 40H or 10H is recognized by the device as the byte program command.
  4. Following the Product ID Read command, read operations will access manufacturer and device ID information. Refer to [Table 16-2](#) for Product ID addresses and data.

### 16.1 Read Array

Upon initial device power-up and after exit from reset, the device defaults to the read array mode. This operation is also initiated by writing the Read Array command. The device remains enabled for reads until another command is written to the device.

Once the internal write state machine (WSM) has started a sector erase or program operation, the device will not recognize the Read Array command until the operation is completed.

### 16.2 Sector Erase

Before a byte can be programmed into a sector, the sector must first be erased. The memory array is organized into multiple sectors that can be individually erased using two different sector erase commands, Sector Erase and Uniform Sector Erase. The Uniform Sector Erase command can be used to erase the main sectors, and it can also be used to erase all of the sub-sectors to allow the memory array to be erased in uniform 64-Kbyte regions. The Sector Erase command is used to erase the individual sub-sectors to provide a more efficient and finer erase granularity. In addition, the Sector Erase command can be used to erase the main sectors as well to allow a single erase command to be used to erase any sector in the memory array. Both sector erase commands require two command cycles to initiate the internally self-timed erase operation.

After issuing a sector erase command, the device's Status Register may be checked to determine the status of the WSM and the erase operation. If the device detects a sector erase error, the Status Register should be cleared before the system software attempts any corrective actions. After a sector erase, the CUI remains in the Read Status Register mode until a new command is issued.

Successful sector erase requires that the corresponding sector's Write-Lock bit be cleared and the corresponding hardware write protect pin ( $\overline{\text{TBL}}$  or  $\overline{\text{WP}}$ ) be inactive. If using the Uniform Sector Erase command to erase all of the sub-sectors, then all of the sub-sectors must have their Write-Lock bits cleared and the  $\overline{\text{TBL}}$  pin must be inactive. If a sector erase is attempted when the sector is locked, the sector erase will fail, and the reason for the failure will be indicated in the Status Register.

The erased state of the memory bits is a logical "1" (erased state of a byte is FFH).

### 16.3 Byte Program

The device is programmed on a byte-by-byte basis. The Byte Program command requires two command cycles with the programming address and data being input on the second command cycle. The device will automatically generate the required internal programming pulses, and all programming operations are completely self-timed. Please note that the byte location being programmed must have already been erased to FFH. A "0" cannot be programmed back to a "1"; only an erase operation can convert "0"s to "1"s.

After the Byte Program command is written, the device's Status Register may be checked to determine the WSM status and the result of the program operation. If a program error is detected, the Status Register should be cleared before any corrective action is taken by the system software. After a byte program operation, the CUI remains in the Read Status Register mode until a new command is issued.

A successful program operation also requires that the corresponding sector's Write-Lock bit be cleared, and the corresponding hardware write protect pin ( $\overline{\text{TBL}}$  or  $\overline{\text{WP}}$ ) be inactive. If a program operation is attempted when the sector is locked, the operation will fail, and the reason for the failure will be indicated in the Status Register.

### 16.4 Read Status Register

The Status Register (SR) may be read to determine when a sector erase or program operation completes and whether the operation completed successfully. The Status Register may be read at any time by writing the Read Status Register command. After writing the Read Status Register command, all subsequent read operations will return data from the Status Register until another valid command is written to the device.

#### 16.4.1 Clear Status Register

Error flags (SR[5,4,1]) in the Status Register can only be set to "1"s by the WSM and can only be reset by the Clear Status Register command. Therefore, if an error is detected, the Status Register must be cleared before beginning another operation to avoid ambiguity.

**Table 16-1.** Status Register (SR)

SR Bit	Name	Description	
7	Write State Machine Status (WSM)	0	<b>Device is BUSY.</b> A program or erase cycle is in progress. SR[6-1] values are invalid when SR[7] is 0.
		1	<b>Device is READY.</b> The device is ready for any operation.
6	Reserved	Reserved for future use.	
5	Erase Status	0	<b>Erase successful.</b> The sector erase operation completed successfully.
		1	<b>Erase failed.</b> The sector erase operation failed. If SR[5,4] are 1, then there was a command sequence error.
4	Program Status	0	<b>Program successful.</b> The byte program operation competed successfully.
		1	<b>Program failed.</b> The program operation failed. If SR[5,4] are 1, then there was a command sequence error.
3:2	Reserved	Reserved for future use.	
1	Device Protect Status <sup>(1)</sup>	0	<b>Sector is unlocked.</b> The sector being erased or programmed is unlocked (not protected).
		1	<b>Sector is hardware write protected or write-locked.</b> The sector being erased or programmed is either hardware write protected by the $\overline{\text{TBL}}$ or $\overline{\text{WP}}$ pin, or it is write-locked.
0	Reserved	Reserved for future use.	

Note: 1. SR[1] does not provide a continuous indication of the Write-Lock bit,  $\overline{\text{TBL}}$  pin, or  $\overline{\text{WP}}$  values. The WSM interrogates the Write-Lock bit,  $\overline{\text{TBL}}$  pin, or  $\overline{\text{WP}}$  pin only after a sector erase or program operation. Depending on the attempted operation, it informs the system whether or not the selected sector is locked.

## 16.5 Product ID Read

The Product ID Read mode is used to identify the product type and the manufacturer as Atmel. Following the Product ID Read command, read cycles from the addresses shown in [Table 16-2](#) retrieve the manufacturer and device ID code. To exit the Product ID Read mode, any valid command can be written to the device.

**Table 16-2.** Product ID Address and Data

Code	Address	Data
Manufacturer ID	000000H	1FH
Device ID	000001H	EEH

## 17. Absolute Maximum Ratings\*

Voltage on Any Pin .....-0.5V to +V<sub>CC</sub> + 0.5V<sup>(1)(2)</sup>

\*NOTICE: Stresses beyond those listed under “Absolute Maximum Ratings” may cause permanent damage to the device. This is a stress rating only and functional operation of the device at these or any other conditions beyond those indicated in the operational sections of this specification is not implied. Exposure to absolute maximum rating conditions for extended periods may affect device reliability.

- Notes:
1. All specified voltages are with respect to GND. During transitions, this level may undershoot to -2.0V for periods of <20 ns. During transitions, this level may overshoot to V<sub>CC</sub> + 2.0V for periods <20 ns.
  2. Do not violate processor or chipset limitations on the  $\overline{\text{INIT}}$  pin.

## 18. Operating Conditions

Temperature and V<sub>CC</sub>

Symbol	Parameter	Test Condition	Min	Max	Unit
T <sub>C</sub>	Operating Temperature <sup>(1)</sup>	Case Temperature	0	+85	°C
V <sub>CC</sub>	V <sub>CC</sub> Supply Voltage		3.0	3.6	V

- Note:
1. The device is designed to operate at temperatures beyond the normal commercial temperature range of 0°C to +70°C.

## 19. Power Supply Specifications – All Interfaces

Symbol	Parameter	Conditions	Min	Max	Units
V <sub>LKO</sub>	V <sub>CC</sub> Lockout Voltage		1.5		V
I <sub>CCSL1</sub>	V <sub>CC</sub> Standby Current (FWH/LPC Interface)	Voltage range of all inputs is V <sub>IH</sub> to V <sub>IL</sub> , FWH4/ $\overline{\text{LFRAME}} = V_{IH}$ , <sup>(2)</sup> V <sub>CC</sub> = 3.6V, f <sub>CLK</sub> = 33 MHz  No internal operations in progress		35	μA
I <sub>CCSL2</sub>	V <sub>CC</sub> Standby Current (FWH/LPC Interface)	FWH4/ $\overline{\text{LFRAME}} = V_{IL}$ <sup>(2)</sup> V <sub>CC</sub> = 3.6V, f <sub>CLK</sub> = 33 MHz  No internal operations in progress		2	mA
I <sub>CCA</sub>	V <sub>CC</sub> Active Read Current (FWH/LPC Interface)	V <sub>CC</sub> = V <sub>CC</sub> Max, FWH4/ $\overline{\text{LFRAME}} = V_{IL}$ <sup>(2)</sup> f <sub>CLK</sub> = 33 MHz  I <sub>OUT</sub> = 0 mA		20	mA
I <sub>PP</sub>	Program or Erase Current	V <sub>CC</sub> = V <sub>CC</sub> Max		60	mA

- Notes:
1. All currents are in RMS unless otherwise noted. These currents are valid for all packages.
  2. V<sub>IH</sub> = 0.9 V<sub>CC</sub>, V<sub>IL</sub> = 0.1 V<sub>CC</sub> per the PCI output V<sub>OH</sub> and V<sub>OL</sub> spec.

## 20. FWH/LPC Interface DC Input/Output Specifications

Symbol	Parameter	Conditions	Min	Max	Units
$V_{IH}^{(1)}$	Input High Voltage		$0.5 V_{CC}$	$V_{CC} + 0.5$	V
$V_{IH}(\overline{INIT})^{(1)(2)}$	$\overline{INIT}$ Input High Voltage		1.35	$V_{CC} + 0.5$	V
$V_{IL}$	Input Low Voltage		-0.5	$0.3 V_{CC}$	V
$V_{IL}(\overline{INIT})^{(2)}$	$\overline{INIT}$ Input Low Voltage			0.85	V
$I_{IL}^{(3)(4)}$	Input Leakage Current	$0 < V_{IN} < V_{CC}$		$\pm 10$	$\mu A$
$V_{OH}$	Output High Voltage	$I_{OUT} = -500 \mu A$	$0.9 V_{CC}$		V
$V_{OL}$	Output Low Voltage	$I_{OUT} = 1.5 \text{ mA}$		$0.1 V_{CC}$	V
$C_{IN}$	Input Pin Capacitance			13	pF
$C_{CLK}$	CLK Pin Capacitance		3	12	pF
$L_{PIN}^{(5)}$	Recommended Pin Inductance			20	nH

- Notes:
- Inputs are not "5-volt safe."
  - Do not violate processor or chipset specifications regarding the  $\overline{INIT}$  pin voltage.
  - Input leakage currents include high-Z output leakage for all bi-directional buffers with high-Z outputs.
  - $I_{IL}$  may be higher on the IC and ID pins (up to 200  $\mu A$ ) if pulled against internal pull-downs. Refer to the pin descriptions
  - Refer to PCI spec.

## 21. FWH/LPC Interface AC Input/Output Specifications

Symbol	Parameter	Condition	Min	Max	Units
$I_{OH(AC)}$	Switching Current High	$0 < V_{OUT} \leq 0.3 V_{CC}$	$-12 V_{CC}$		mA
		$0.3 V_{CC} < V_{OUT} < 0.9 V_{CC}$	$-17.1 (V_{CC} - V_{OUT})$		mA
		$0.7 V_{CC} < V_{OUT} < V_{CC}$		Note 2	
	(Test Point)	$V_{OUT} = 0.7 V_{CC}$		$-32 V_{CC}$	mA
$I_{OL(AC)}$	Switching Current Low	$V_{CC} > V_{OUT} \geq 0.6 V_{CC}$	$16 V_{CC}$		mA
		$0.6 V_{CC} > V_{OUT} > 0.1 V_{CC}$	$-17.1 (V_{CC} - V_{OUT})$		mA
		$0.18 V_{CC} > V_{OUT} > 0$		Note 3	
	(Test Point)	$V_{OUT} = 0.18 V_{CC}$		$38 V_{CC}$	mA
$I_{CL}$	Low Clamp Current	$-3 < V_{IN} \leq -1$	$-25 + (V_{IN} + 1)/0.015$		mA
$I_{CH}$	High Clamp Current	$V_{CC} + 4 > V_{IN} \geq V_{CC} + 1$	$25 + (V_{IN} - V_{CC} - 1)/0.015$		mA
slewr	Output Rise Slew Rate	$0.2 V_{CC} - 0.6 V_{CC} \text{ load}^{(1)}$	1	4	V/ns
slewf	Output Fall Slew Rate	$0.6 V_{CC} - 0.2 V_{CC} \text{ load}^{(1)}$	1	4	V/ns

- Notes:
- PCI specification output load is used.
  - $I_{OH} = (98.0/V_{CC}) * (V_{OUT} - V_{CC}) * (V_{OUT} + 0.4 V_{CC})$ .
  - $I_{OL} = (256/V_{CC}) * V_{OUT} (V_{CC} - V_{OUT})$ .

## 22. FWH/LPC Interface AC Timing Specifications

### 22.1 Clock Specification

Symbol	Parameter	Condition	Min	Max	Units
$t_{CYC}$	CLK Cycle Time <sup>(1)</sup>		30	•	ns
$t_{HIGH}$	CLK High Time		11		ns
$t_{LOW}$	CLK Low Time		11		ns
–	CLK Slew Rate	peak-to-peak	1	4	V/ns
–	$\overline{RST}$ or $\overline{INIT}$ Slew Rate <sup>(2)</sup>		50		mV/ns

- Notes: 1. PCI components must work with any clock frequency between nominal DC and 33 MHz. Frequencies less than 16 MHz may be guaranteed by design rather than testing.  
 2. Applies only to rising edge of signal.

### 22.2 Clock Waveform

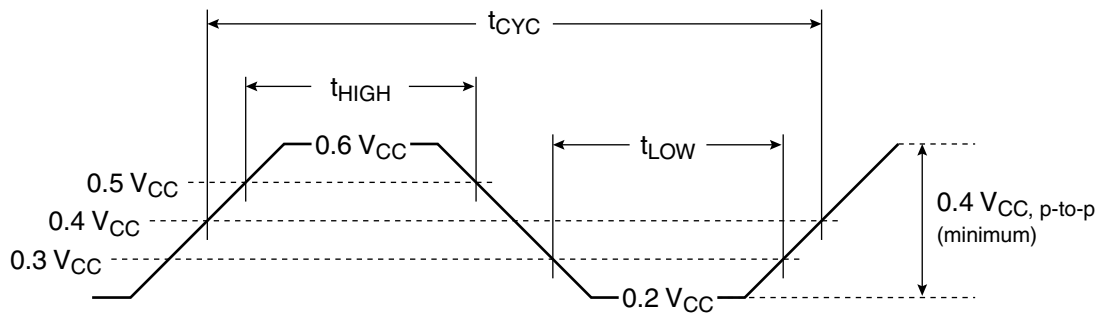

## 23. Signal Timing Parameters

Symbol	PCI Symbol	Parameter	Min	Max	Units
$t_{CHQX}$	$t_{VAL}$	CLK to Data Out <sup>(1)</sup>	2	11	ns
$t_{CHQX}$	$t_{ON}$	CLK to Active (Float to Active Delay) <sup>(2)</sup>	2		ns
$t_{CHQZ}$	$t_{OFF}$	CLK to Inactive (Active to Float Delay) <sup>(2)</sup>		28	ns
$t_{AVCH}$ $t_{DVCH}$	$t_{SU}$	Input Set-up Time <sup>(3)</sup>	7		ns
$t_{CHAX}$ $t_{CHDX}$	$t_H$	Input Hold Time <sup>(3)</sup>	0		ns
$t_{VSPL}$	$t_{RST}$	Reset Active Time after Power Stable	1		ms
$t_{CSPL}$	$t_{RST-CLK}$	Reset Active Time after CLK Stable	100		$\mu$ s
$t_{PLQZ}$	$t_{RST-OFF}$	Reset Active to Output Float Delay <sup>(2)</sup>		48	ns

- Notes: 1. Minimum and maximum times have different loads. See PCI spec.  
 2. For purposes of Active/Float timing measurements, the high-Z or “off” state is defined to be when the total current delivered through the component pin is less than or equal to the leakage current specification.  
 3. This parameter applies to any input type (excluding CLK).

## 24. Output Timing Parameters

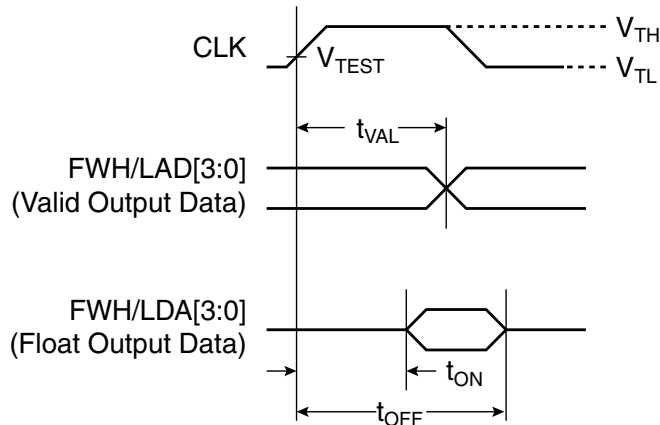

## 25. Input Timing Parameters

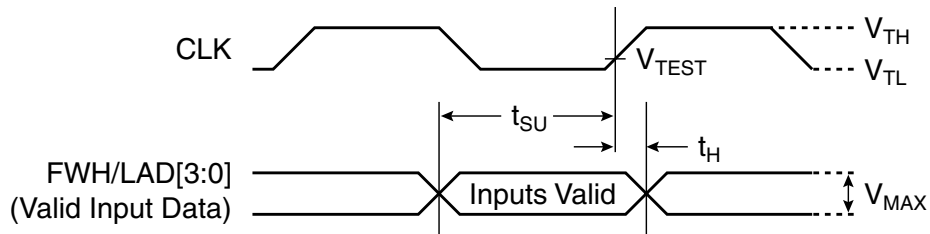

## 26. Interface Measurement Condition Parameters

Symbol	Value	Units
$V_{TH}^{(1)}$	$0.6 V_{CC}$	V
$V_{TL}^{(1)}$	$0.2 V_{CC}$	V
$V_{TEST}$	$0.4 V_{CC}$	V
$V_{MAX}^{(1)}$	$0.4 V_{CC}$	V
Input Signal Edge Rate	1 V/ns	

Note: 1. The input test environment is done with  $0.1 V_{CC}$  of overdrive over  $V_{IH}$  and  $V_{IL}$ . Timing parameters must be met with no more overdrive than this.  $V_{MAX}$  specifies the maximum peak-to-peak waveform allowed for measuring the input timing. Production testing may use different voltage values, but must correlate results back to these parameters.

## 27. Reset Operations

Symbol	Parameter	Min	Max	Unit
$t_{PLPH}^{(1)}$	$\overline{RST}$ or $\overline{INIT}$ Pulse Low Time (If $\overline{RST}$ or $\overline{INIT}$ is tied to $V_{CC}$ , this specification is not applicable)	100		ns
$t_{PHFV}$	$\overline{RST}$ or $\overline{INIT}$ High to FWH4/ $\overline{FRAME}$ Low	1		$\mu$ s

Note: 1. A reset latency of 20  $\mu$ s will occur if a reset procedure is performed during a programming or erase operation.

## 28. AC Waveform for Reset Operation

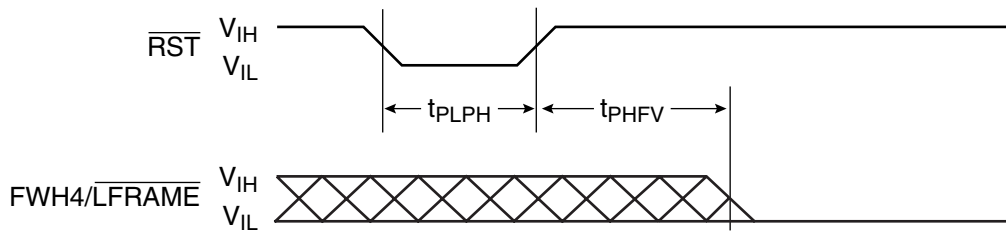

## 29. Programming and Erase Times

Parameter	Typ <sup>(1)</sup>	Max	Unit
Byte Program Time <sup>(2)</sup>	30	50	μs
Sector Erase Time <sup>(2)</sup>	150	500	ms

- Notes: 1. Typical values measured at  $T_A = +25^\circ\text{C}$  and nominal voltages.  
 2. Excludes system-level overhead.

## 30. Electrical Characteristics For A/A Mux Interface

Certain specifications differ from the previous sections when programming using the A/A Mux interface. The following sub-sections provide this data. Any information that is not shown here is not specific to the A/A Mux interface and uses the FWH/LPC interface specifications.

### 30.1 A/A Mux Interface DC Input/Output Specifications

Symbol	Parameter	Conditions	Min	Max	Unit
$V_{IH}^{(1)}$	Input High Voltage		$0.5 V_{CC}$	$V_{CC} + 0.5$	V
$V_{IL}$	Input Low Voltage		-0.5	0.8	V
$I_{IL}^{(2)(3)}$	Input Leakage Current	$V_{CC} = V_{CC} \text{ max,}$ $V_{OUT} = V_{CC} \text{ or GND}$		±10	μA
$V_{OH}$	Output High Voltage	$V_{CC} = V_{CC} \text{ min, } I_{OH} = -2.5 \text{ mA}$ $V_{CC} = V_{CC} \text{ min, } I_{OH} = -100 \text{ μA}$	$0.85 V_{CC} \text{ min}$ $V_{CC} = 0.4$		V V
$V_{OL}$	Output Low Voltage	$V_{CC} = V_{CC} \text{ min, } I_{OL} = 2 \text{ mA}$		0.4	V
$C_{IN}$	Input Pin Capacitance			13	pF
$C_{CLK}$	CLK Pin Capacitance		3	12	pF
$L_{PIN}^{(4)}$	Recommended Pin Inductance			20	nH

- Notes: 1. Inputs are not “5-volt safe.”  
 2. Input leakage currents include high-Z output leakage for all bi-directional buffers with high-Z outputs.  
 3.  $I_{IL}$  may be higher on the IC and ID pins (up to 200 μA) if pulled against internal pull-downs. Refer to the pin descriptions.  
 4. Refer to PCI spec.

### 31. Reset Operations

Symbol	Parameter	Min	Max	Unit
$t_{PLPH}$	$\overline{RST}$ Pulse Low Time (If $\overline{RST}$ is tied to $V_{CC}$ , this specification is not applicable.)	100		ns
$t_{PLRH}$	$\overline{RST}$ Low to Reset during Sector Erase or Program <sup>(1)(2)</sup>		20	$\mu$ s
$t_{PHAV}$	$\overline{RST}$ High to Row Address Setup <sup>(2)</sup>	1		$\mu$ s

- Notes: 1. If  $\overline{RST}$  is asserted when the WSM is not busy ( $RDY/\overline{BSY} = 1$ ), the reset will complete within 100 ns.  
 2. A reset recovery time,  $t_{PHAV}$ , is required from the latter of  $RDY/\overline{BSY}$  or  $\overline{RST}$  going high until addresses are valid.

### 32. AC Waveforms for Reset Operations

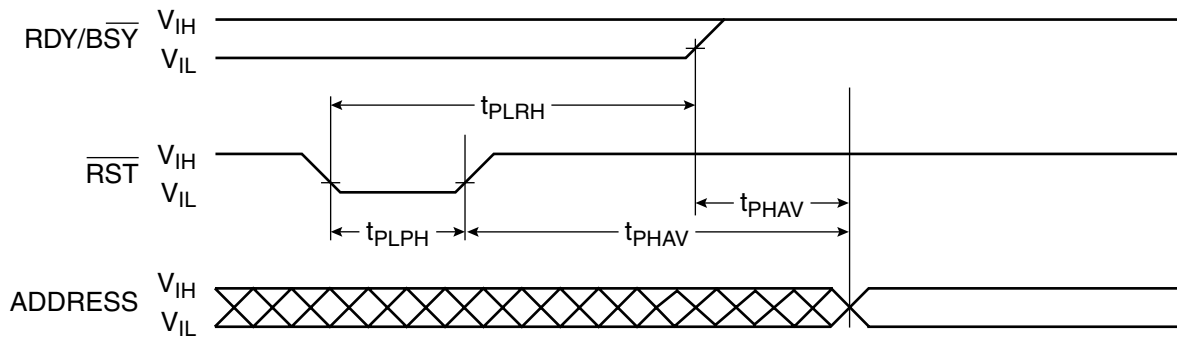

### 33. A/A Mux Interface Read-only Operations<sup>(1)(3)</sup>

Symbol	Parameter	Min	Max	Units
$t_{AVAV}$	Read Cycle Time	250		ns
$t_{AVCL}$	Row Address Setup to $R/\overline{C}$ Low	50		ns
$t_{CLAX}$	Row Address Hold from $R/\overline{C}$ Low	50		ns
$t_{AVCH}$	Column Address Setup to $R/\overline{C}$ High	50		ns
$t_{CHAX}$	Column Address Hold from $R/\overline{C}$ High	50		ns
$t_{CHQV}$	$R/\overline{C}$ High to Output Delay <sup>(2)</sup>		150	ns
$t_{GLQV}$	$\overline{OE}$ Low to Output Delay <sup>(2)</sup>		50	ns
$t_{PHAV}$	$\overline{RST}$ High to Row Address Setup	1		$\mu$ s
$t_{GLQX}$	$\overline{OE}$ Low to Output in Low-Z	0		ns
$t_{GHQZ}$	$\overline{OE}$ High to Output in High-Z		50	ns
$t_{QXGH}$	Output Hold from $\overline{OE}$ High	0		ns

- Note:
1. See AC Input/Output Reference Waveform for maximum allowable input slew rate.
  2.  $\overline{OE}$  may be delayed up to  $t_{CHQV} - t_{GLQV}$  after the rising edge of  $R/\overline{C}$  without impact on  $t_{CHQV}$ .
  3.  $T_C = 0^\circ\text{C}$  to  $+85^\circ\text{C}$ ,  $V_{CC} = 3.0\text{V}$  to  $3.6\text{V}$ .

### 34. A/A Mux Read Timing Diagram

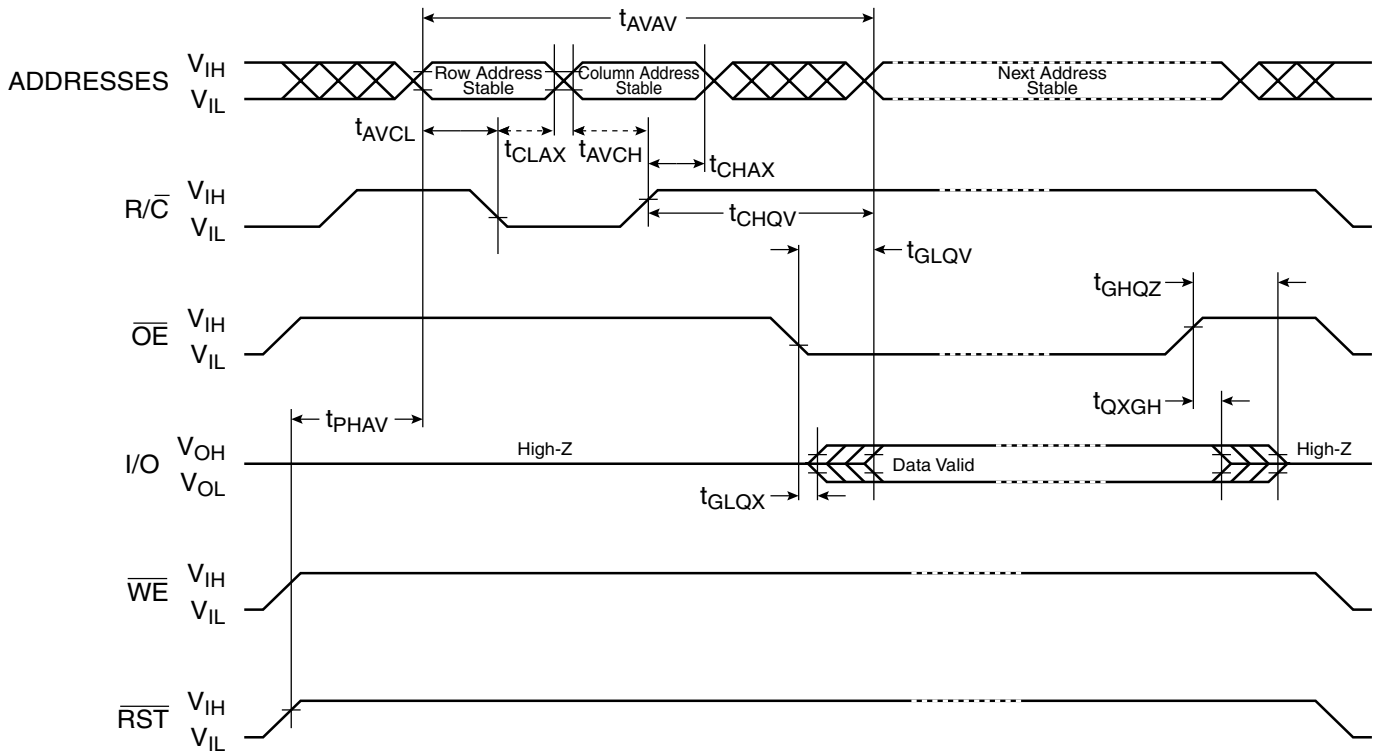

### 35. A/A Mux Interface Write Operations<sup>(1)</sup>

Symbol	Parameter	Min	Max	Units
$t_{PHWL}$	$\overline{RST}$ High Recovery to $\overline{WE}$ Low	1		$\mu s$
$t_{WLWH}$	Write Pulse Width Low	100		ns
$t_{DVWH}$	Data Setup to $\overline{WE}$ High	50		ns
$t_{WHDX}$	Data Hold from $\overline{WE}$ High	5		ns
$t_{AVCL}$	Row Address Setup to $R/\overline{C}$ Low	50		ns
$t_{CLAX}$	Row Address Hold from $R/\overline{C}$ Low	50		ns
$t_{AVCH}$	Column Address Setup to $R/\overline{C}$ High	50		ns
$t_{CHAX}$	Column Address Hold from $R/\overline{C}$ High	50		ns
$t_{WHWL}$	Write Pulse Width High	100		ns
$t_{CHWH}$	$R/\overline{C}$ High Setup to $\overline{WE}$ High	50		ns
$t_{WHGL}$	Write Recovery before Read		150	ns
$t_{WHSV}$	Write Recovery before a Valid SRD (Status Register Data) Read		150	ns
$t_{WHRL}$	$\overline{WE}$ High to $RDY/\overline{BSY}$ Going Low	0		ns

Note: 1.  $T_C = 0^\circ C$  to  $+85^\circ C$ ,  $V_{CC} = 3.0V$  to  $3.6V$ .

### 36. A/A Mux Write Timing Diagram

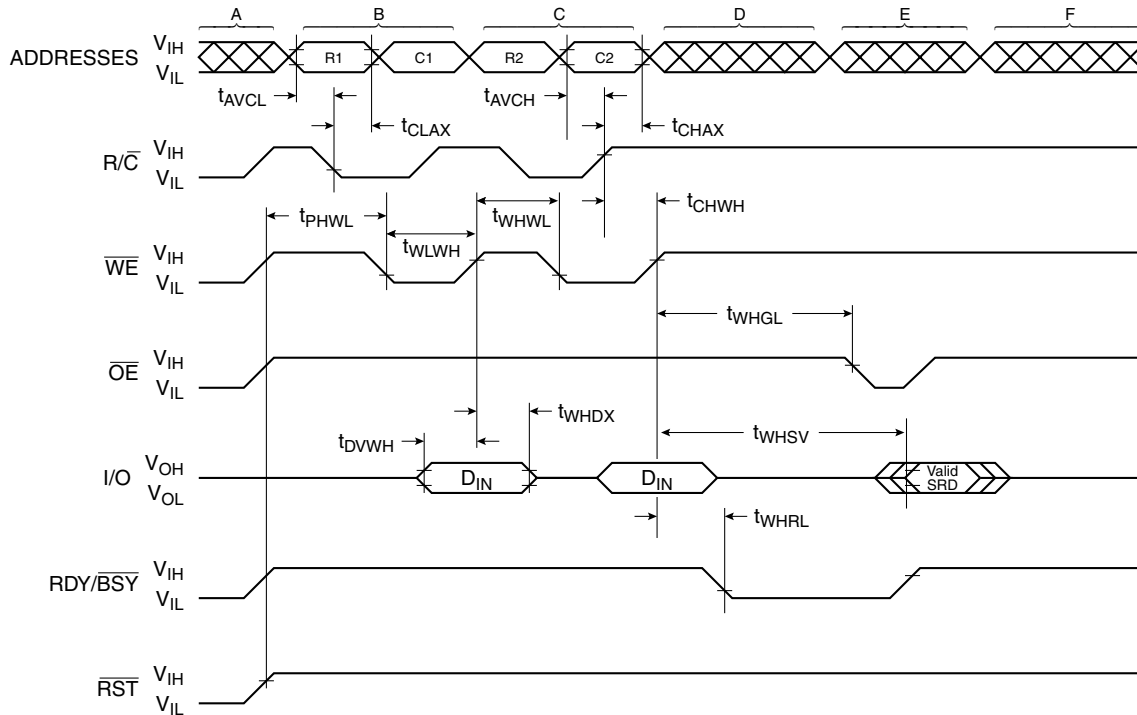

**NOTES**

- A =  $V_{CC}$  power-up and standby
- B = Write sector erase or program setup
- C = Write sector erase confirm or valid address and data
- D = Automated erase or program delay
- E = Read status register data
- F = Ready to write another command

**37. Ordering Information**

**37.1 Standard Package**

$I_{CC}$ (mA)		Ordering Code	Package	Operation Range
Active	Standby			
20	0.03	AT49LH004-33JC AT49LH004-33TC	32J 40T	Extended Commercial (0° to 85°C)

**37.2 Green Package Option (Pb/Halide-free)**

$I_{CC}$ (mA)		Ordering Code	Package	Operation Range
Active	Standby			
20	0.03	AT49LH004-33JX AT49LH004-33TX	32J 40T	Extended Commercial (0° to 85°C)

Package Type	
<b>32J</b>	32-lead, Plastic J-leaded Chip Carrier Package (PLCC)
<b>40T</b>	40-lead, Thin Small Outline Package (TSOP)

## 38. Packaging Information

### 38.1 32J – PLCC

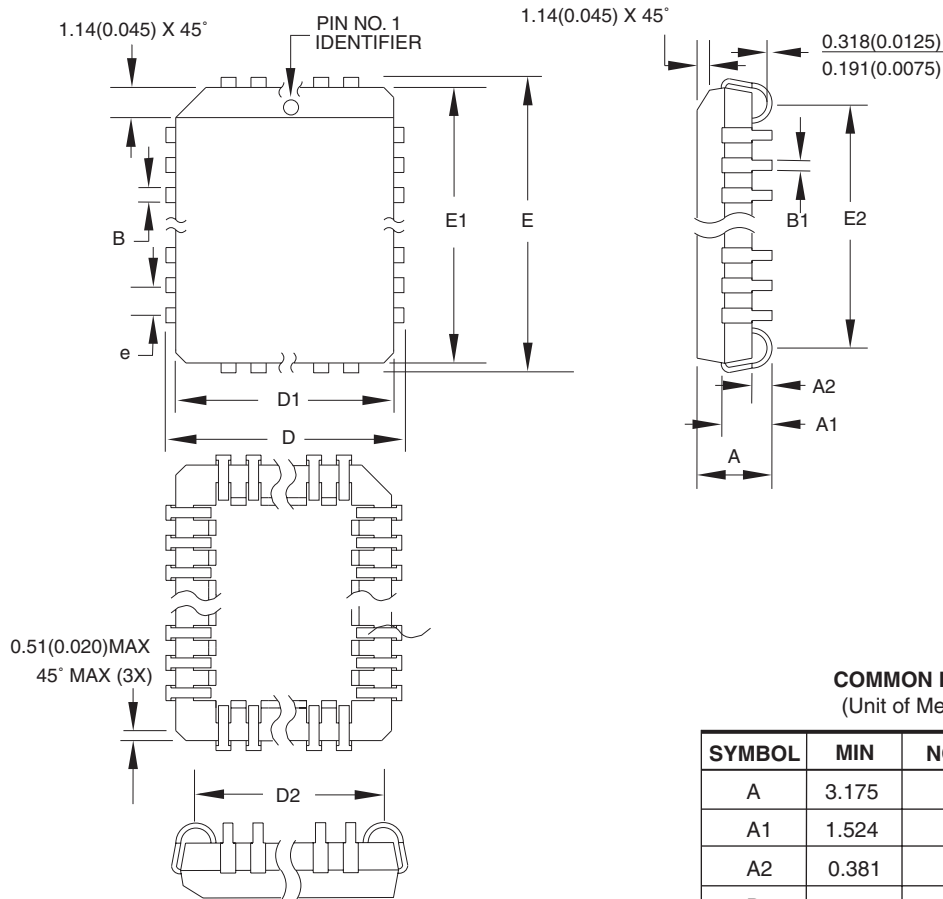

**COMMON DIMENSIONS**  
(Unit of Measure = mm)

SYMBOL	MIN	NOM	MAX	NOTE
A	3.175	–	3.556	
A1	1.524	–	2.413	
A2	0.381	–	–	
D	12.319	–	12.573	
D1	11.354	–	11.506	Note 2
D2	9.906	–	10.922	
E	14.859	–	15.113	
E1	13.894	–	14.046	Note 2
E2	12.471	–	13.487	
B	0.660	–	0.813	
B1	0.330	–	0.533	
e	1.270 TYP			

- Notes:
1. This package conforms to JEDEC reference MS-016, Variation AE.
  2. Dimensions D1 and E1 do not include mold protrusion. Allowable protrusion is .010" (0.254 mm) per side. Dimension D1 and E1 include mold mismatch and are measured at the extreme material condition at the upper or lower parting line.
  3. Lead coplanarity is 0.004" (0.102 mm) maximum.

10/04/01



2325 Orchard Parkway  
San Jose, CA 95131

**TITLE**

**32J**, 32-lead, Plastic J-leaded Chip Carrier (PLCC)

**DRAWING NO.**

32J

**REV.**

B

38.2 40T – TSOP

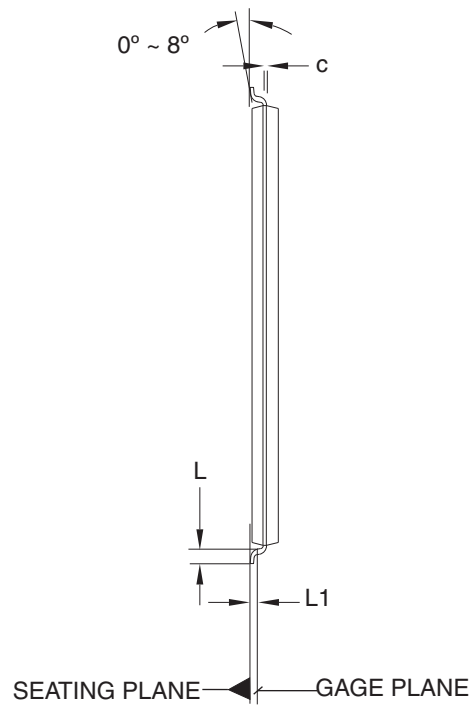
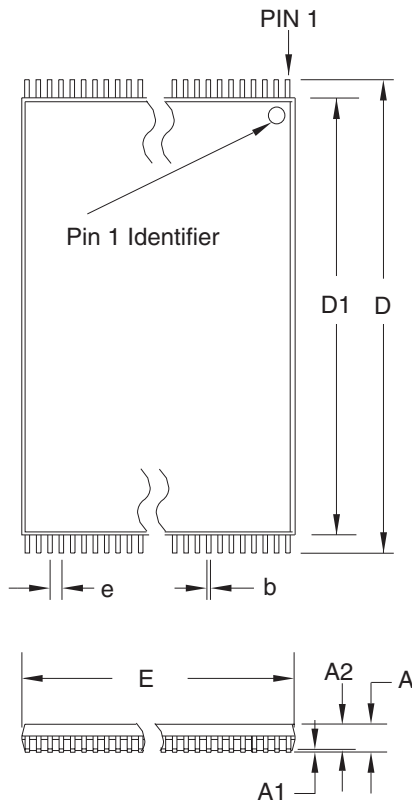

COMMON DIMENSIONS  
(Unit of Measure = mm)

SYMBOL	MIN	NOM	MAX	NOTE
A	–	–	1.20	
A1	0.05	–	0.15	
A2	0.95	1.00	1.05	
D	19.80	20.00	20.20	
D1	18.30	18.40	18.50	Note 2
E	9.90	10.00	10.10	Note 2
L	0.50	0.60	0.70	
L1	0.25 BASIC			
b	0.17	0.22	0.27	
c	0.10	–	0.21	
e	0.50 BASIC			

- Notes:
1. This package conforms to JEDEC reference MO-142, Variation CD.
  2. Dimensions D1 and E do not include mold protrusion. Allowable protrusion on E is 0.15 mm per side and on D1 is 0.25 mm per side.
  3. Lead coplanarity is 0.10 mm maximum.

10/18/01



2325 Orchard Parkway  
San Jose, CA 95131

TITLE

40T, 40-lead (10 x 20 mm Package) Plastic Thin Small Outline Package, Type I (TSOP)

DRAWING NO.

40T

REV.

B





## Atmel Corporation

2325 Orchard Parkway  
San Jose, CA 95131, USA  
Tel: 1(408) 441-0311  
Fax: 1(408) 487-2600

## Regional Headquarters

### Europe

Atmel Sarl  
Route des Arsenalux 41  
Case Postale 80  
CH-1705 Fribourg  
Switzerland  
Tel: (41) 26-426-5555  
Fax: (41) 26-426-5500

### Asia

Room 1219  
Chinachem Golden Plaza  
77 Mody Road Tsimshatsui  
East Kowloon  
Hong Kong  
Tel: (852) 2721-9778  
Fax: (852) 2722-1369

### Japan

9F, Tonetsu Shinkawa Bldg.  
1-24-8 Shinkawa  
Chuo-ku, Tokyo 104-0033  
Japan  
Tel: (81) 3-3523-3551  
Fax: (81) 3-3523-7581

## Atmel Operations

### Memory

2325 Orchard Parkway  
San Jose, CA 95131, USA  
Tel: 1(408) 441-0311  
Fax: 1(408) 436-4314

### Microcontrollers

2325 Orchard Parkway  
San Jose, CA 95131, USA  
Tel: 1(408) 441-0311  
Fax: 1(408) 436-4314

La Chantrerie  
BP 70602  
44306 Nantes Cedex 3, France  
Tel: (33) 2-40-18-18-18  
Fax: (33) 2-40-18-19-60

### ASIC/ASSP/Smart Cards

Zone Industrielle  
13106 Rousset Cedex, France  
Tel: (33) 4-42-53-60-00  
Fax: (33) 4-42-53-60-01

1150 East Cheyenne Mtn. Blvd.  
Colorado Springs, CO 80906, USA  
Tel: 1(719) 576-3300  
Fax: 1(719) 540-1759

Scottish Enterprise Technology Park  
Maxwell Building  
East Kilbride G75 0QR, Scotland  
Tel: (44) 1355-803-000  
Fax: (44) 1355-242-743

### RF/Automotive

Theresienstrasse 2  
Postfach 3535  
74025 Heilbronn, Germany  
Tel: (49) 71-31-67-0  
Fax: (49) 71-31-67-2340

1150 East Cheyenne Mtn. Blvd.  
Colorado Springs, CO 80906, USA  
Tel: 1(719) 576-3300  
Fax: 1(719) 540-1759

### Biometrics/Imaging/Hi-Rel MPU/ High Speed Converters/RF Datacom

Avenue de Rochepleine  
BP 123  
38521 Saint-Egreve Cedex, France  
Tel: (33) 4-76-58-30-00  
Fax: (33) 4-76-58-34-80

---

## Literature Requests

[www.atmel.com/literature](http://www.atmel.com/literature)

**Disclaimer:** The information in this document is provided in connection with Atmel products. No license, express or implied, by estoppel or otherwise, to any intellectual property right is granted by this document or in connection with the sale of Atmel products. **EXCEPT AS SET FORTH IN ATMEL'S TERMS AND CONDITIONS OF SALE LOCATED ON ATMEL'S WEB SITE, ATMEL ASSUMES NO LIABILITY WHATSOEVER AND DISCLAIMS ANY EXPRESS, IMPLIED OR STATUTORY WARRANTY RELATING TO ITS PRODUCTS INCLUDING, BUT NOT LIMITED TO, THE IMPLIED WARRANTY OF MERCHANTABILITY, FITNESS FOR A PARTICULAR PURPOSE, OR NON-INFRINGEMENT. IN NO EVENT SHALL ATMEL BE LIABLE FOR ANY DIRECT, INDIRECT, CONSEQUENTIAL, PUNITIVE, SPECIAL OR INCIDENTAL DAMAGES (INCLUDING, WITHOUT LIMITATION, DAMAGES FOR LOSS OF PROFITS, BUSINESS INTERRUPTION, OR LOSS OF INFORMATION) ARISING OUT OF THE USE OR INABILITY TO USE THIS DOCUMENT, EVEN IF ATMEL HAS BEEN ADVISED OF THE POSSIBILITY OF SUCH DAMAGES.** Atmel makes no representations or warranties with respect to the accuracy or completeness of the contents of this document and reserves the right to make changes to specifications and product descriptions at any time without notice. Atmel does not make any commitment to update the information contained herein. Unless specifically provided otherwise, Atmel products are not suitable for, and shall not be used in, automotive applications. Atmel's products are not intended, authorized, or warranted for use as components in applications intended to support or sustain life.

© Atmel Corporation 2005. All rights reserved. Atmel®, logo and combinations thereof, Everywhere You Are® and others, are registered trademarks or trademarks of Atmel Corporation or its subsidiaries. Other terms and product names may be trademarks of others.



Printed on recycled paper.

3383D-FLASH-6/05