



Features

- JA version available to 100K ohms
- 10 pin with 8 resistors in bussed type for pull up/down circuit
- Lead free version available (see How to Order "Termination" options)
- RoHS compliant*
- Convex termination style
- Resistance tolerance $\pm 5\%$
- E24 Series from 10 ohms to 43K ohms
- Suitable for all types of soldering processes
- Paper tape on plastic reel for automatic placement

Model CAY17 - Bussed Resistor Array

Characteristics

Number of Resistors....8 (bussed circuit)
 Power Rating per Resistor @ 70 °C31 mW
 Package Power Rating @ 70 °C250 mW
 Operating Temperature Range-55 °C to +125 °C
 Derated to 0 Load @+125 °C
 Max. Working Voltage25 V
 Max. Overload Voltage.....50 V
 Resistance Tolerance $\pm 5\%$
 Resistance Range/E24 Series
 JA version10 ohms to 100K ohms
 JB version10 ohms to 43K ohms
 T.C.R. ± 250 ppm/°C

Construction

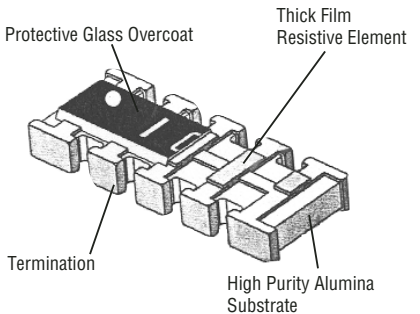

How To Order

CA Y 17 - 103 J A

- Chip Arrays _____
 Type _____
 • Y = Convex
 Model _____
 • 17 = 1206 Package Size
 Resistance Code _____
 • 103 = 10K ohms
 (JA range: 10 ohms to 100K ohms;
 JB range: 10 ohms to 43K ohms)
 Resistance Tolerance _____
 • J = $\pm 5\%$
 Resistors _____
 • A = Common from terminal 5 to 10
 • B = Common from terminal 1 to 6
 Terminations _____
 • LF = Tin-plated (lead free)
 • Blank = Solder-plated

Product Dimensions

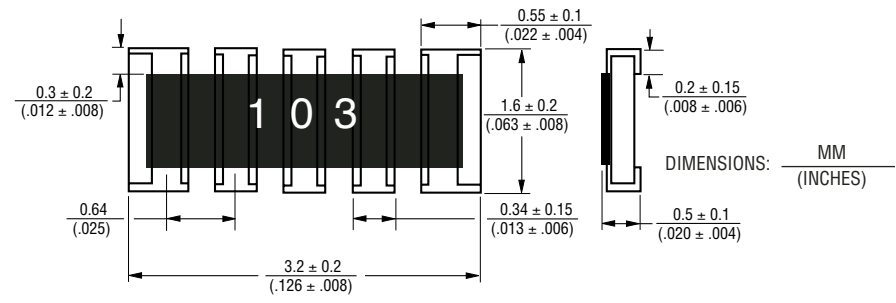

Derating Curve

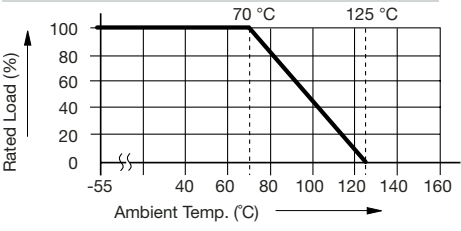

Bussed Circuits - Option A

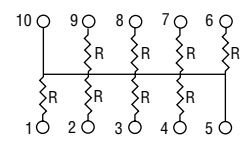

Packaging Dimensions

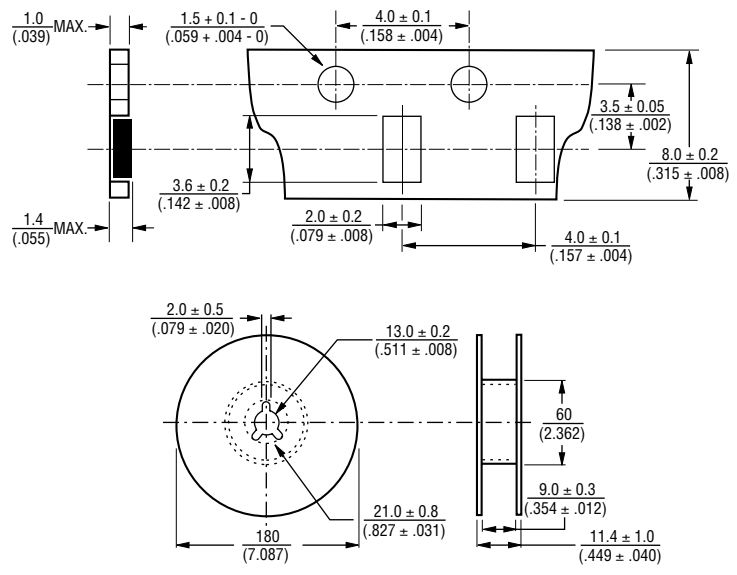

*RoHS Directive 2002/95/EC Jan 27 2003 including Annex Specifications are subject to change without notice. Customers should verify actual device performance in their specific applications.

Model CAY17 - Bussed Resistor Array

BOURNS®

Soldering Profile for Lead Free Chip Resistors and Arrays

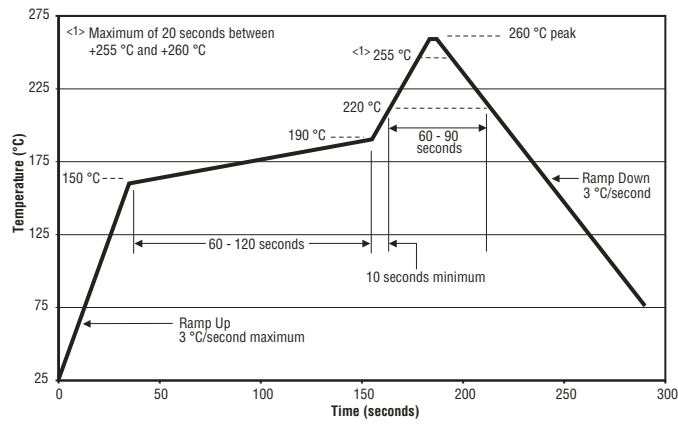

Chip Resistor Arrays - Application Note

BOURNS®

Component Placement

- Reduce the mechanical stress to a minimum during and after placing of the unit in order not to damage the terminals and protective coating.
- Misplacement of components may cause solder bridges.

Soldering

- Reflow soldering: Recommendation is shown in the following chart.
- Wave soldering: Recommendation according to IEC standards.
- Hand soldering: Don't touch the protective coating of the part. Solder within 3 seconds when the temperature is over 280 °C.

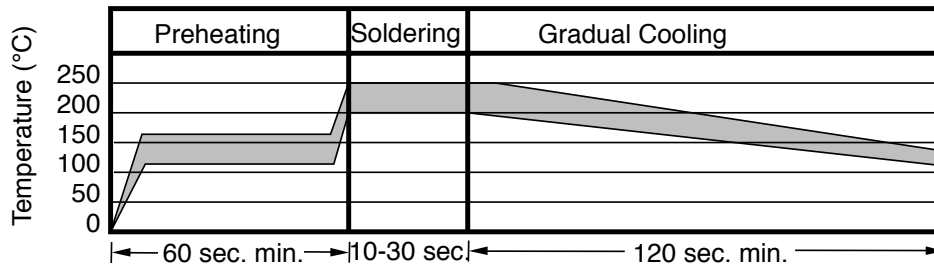

Cleaning

A recommended cleaning method is shown in the following table.

Solvents	Cleaning Condition	
	Dipping	Ultrasonic Wave Washing
Isopropyl alcohol	5 minutes maximum	1 minute maximum Power: 20 W/L Frequency: 10 to 100 kHz