

Si-MMIC-Amplifier in SIEGET 25-Technologie

- Cascadable 50 Ω-gain block
- Unconditionally stable
- Gain  $|S_{21}|^2 = 13$  dB at 1.8 GHz  
 $IP_{3out} = +13$  dBm at 1.8 GHz  
 $(V_D = 3$  V,  $I_D =$  typ. 6.7 mA)
- Noise figure  $NF = 2.3$  dB at 1.8 GHz
- Reverse isolation  $> 28$  dB and  
return loss  $IN / OUT > 12$  dB at 1.8 GHz

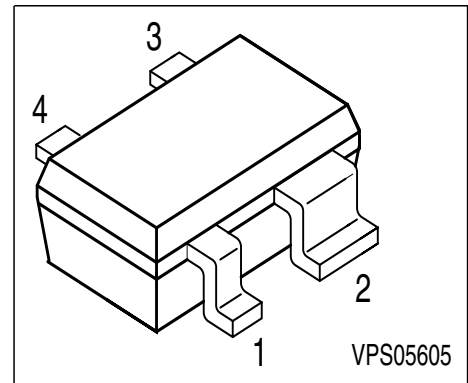

Circuit Diagram

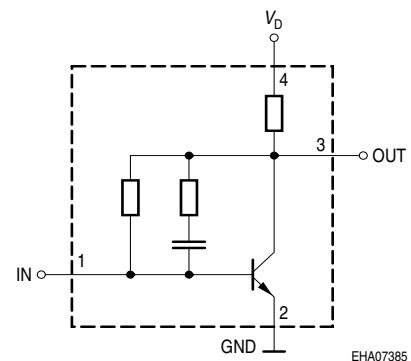

**ESD:** Electrostatic discharge sensitive device, observe handling precaution!

Type	Marking	Pin Configuration				Package
BGA420	BLs	1, IN	2, GND	3, OUT	4, VD	SOT343

Maximum Ratings

Parameter	Symbol	Value	Unit
Device current	$I_D$	15	mA
Device voltage	$V_D$	6	V
Total power dissipation $T_S = 110$ °C	$P_{tot}$	90	mW
RF input power	$P_{RFIn}$	0	dBm
Junction temperature	$T_j$	150	°C
Ambient temperature	$T_A$	-65 ... 150	
Storage temperature	$T_{stg}$	-65 ... 150	

Thermal Resistance

Junction - soldering point <sup>1)</sup>	$R_{thJS}$	$\leq 410$	K/W
------------------------------------------	------------	------------	-----

<sup>1)</sup>For calculation of  $R_{thJA}$  please refer to Application Note Thermal Resistance

**Electrical Characteristics** at  $T_A = 25\text{ }^\circ\text{C}$ , unless otherwise specified.

Parameter	Symbol	Values			Unit
		min.	typ.	max.	
<b>AC characteristics</b> $V_D = 3\text{ V}$ , $Z_0 = 50\ \Omega$					
Device current	$I_D$	5.4	6.7	8	mA
Insertion power gain	$ S_{21} ^2$				dB
$f = 0.1\text{ GHz}$		17	19	-	
$f = 1\text{ GHz}$		15	17	-	
$f = 1.8\text{ GHz}$		11	13	-	
Reverse isolation	S12	25	28	-	dBm
$f = 1.8\text{ GHz}$					
Noise figure	NF				
$f = 0.1\text{ GHz}$		-	1.9	2.3	
$f = 1\text{ GHz}$		-	2.2	2.6	
$f = 1.8\text{ GHz}$		-	2.3	2.7	
Intercept point at the output	$IP_{3out}$	10	13	-	dBm
$f = 1\text{ GHz}$					
1dB compression point	$P_{-1dB}$	-6	-2.5	-	dB
$f = 1\text{ GHz}$					
Return loss input	$RL_{in}$	8	11	-	dB
$f = 1.8\text{ GHz}$					
Return loss output	$RL_{out}$	12	16	-	
$f = 1.8\text{ GHz}$					

### Typical biasing configuration

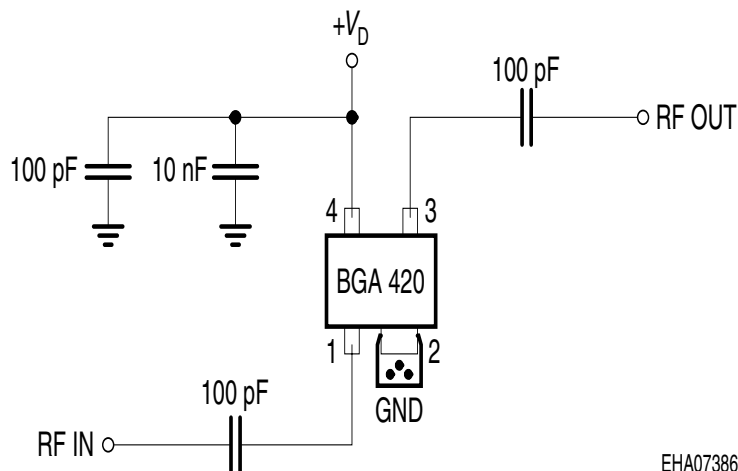

EHA07386

- Note: 1) Large-value capacitors should be connected from pin 4 to ground right at the device to provide a low impedance path.  
 2) The use of plated through holes right at pin 2 is essential for pc-board-applications. Thin boards are recommended to minimize the parasitic inductance to ground.

**Typical S-Parameters at  $T_A = 25\text{ }^\circ\text{C}$**

$f$ GHz	$S_{11}$		$S_{21}$		$S_{12}$		$S_{22}$	
	MAG	ANG	MAG	ANG	MAG	ANG	MAG	ANG
$V_D = 3\text{ V}, Z_0 = 50\text{ }\Omega$								
0.1	0.5686	-8.5	9.314	170.6	0.0268	12.7	0.2808	-8.6
0.5	0.5066	-19.2	8.393	149.4	0.0248	11.7	0.2613	-3.8
0.8	0.4404	-28.7	7.352	135.2	0.0236	25.6	0.2361	-6.7
1	0.3904	-34.6	6.69	126.8	0.024	35.9	0.2144	-9
1.5	0.2841	-50.5	5.244	111.1	0.0314	57.2	0.1398	-15
1.8	0.2343	-60.6	4.567	104	0.0378	63.5	0.0979	-18.2
1.9	0.2136	-64.1	4.355	102	0.0406	66.1	0.0838	-21.5
2	0.2062	-68.4	4.165	99.7	0.0426	67.2	0.0689	-22.2
2.4	0.1688	-89.7	3.417	91.7	0.0549	71.4	0.0224	-48
3	0.1558	-104.9	2.861	85.3	0.0682	73.1	0.0284	-147.5

**Spice-model BGA 420**

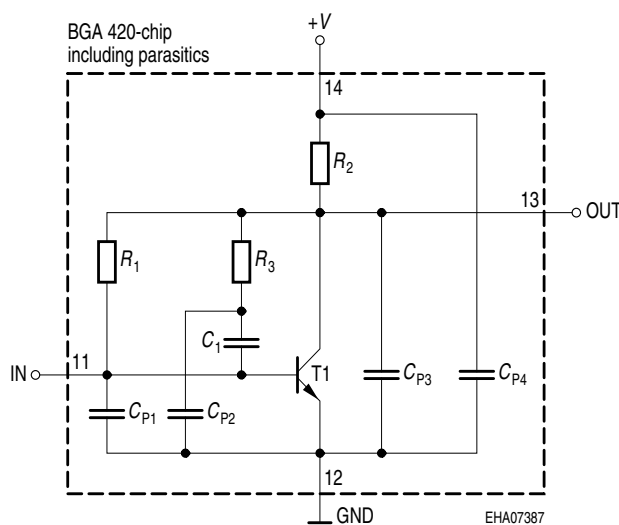

T1	T501
$R_1$	14.5k $\Omega$
$R_2$	140 $\Omega$
$R_3$	2.4k $\Omega$
$C_1$	2.3pF
$C_{P1}$	0.2pF
$C_{P2}$	0.2pF
$C_{P3}$	0.6pF
$C_{P4}$	0.1pF

**Transistor Chip Data T1 (Berkley-SPICE 2G.6 Syntax) :**

IS =	0.21024	fA	BF =	83.23	-	NF =	1.0405	-
VAF =	39.251	V	IKF =	0.16493	A	ISE =	15.761	fA
NE =	1.7763	-	BR =	10.526	-	NR =	0.96647	-
VAR =	34.368	V	IKR =	0.25052	A	ISC =	0.037223	fA
NC =	1.3152	-	RB =	15	$\Omega$	IRB =	0.21215	A
RBM =	1.3491	$\Omega$	RE =	1.9289		RC =	0.12691	$\Omega$
CJE =	3.7265	fF	VJE =	0.70367	V	MJE =	0.37747	-
TF =	4.5899	ps	XTF =	0.3641	-	VTF =	0.19762	V
ITF =	1.3364	mA	PTF =	0	deg	CJC =	96.941	fF
VJC =	0.99532	V	MJC =	0.48652	-	XCJC =	0.08161	-
TR =	1.4935	ns	CJS =	0	fF	VJS =	0.75	V
MJS =	0	-	XTB =	0	-	EG =	1.11	eV
XTI =	3	-	FC =	0.99469	-	TNOM	300	K

**C'-E'-Diode Data (Berkley-SPICE 2G.6 Syntax) :**

IS =	2	fA	N =	1.02	-	RS =	20	$\Omega$
------	---	----	-----	------	---	------	----	----------

All parameters are ready to use, no scaling is necessary

**Package Equivalent Circuit:**

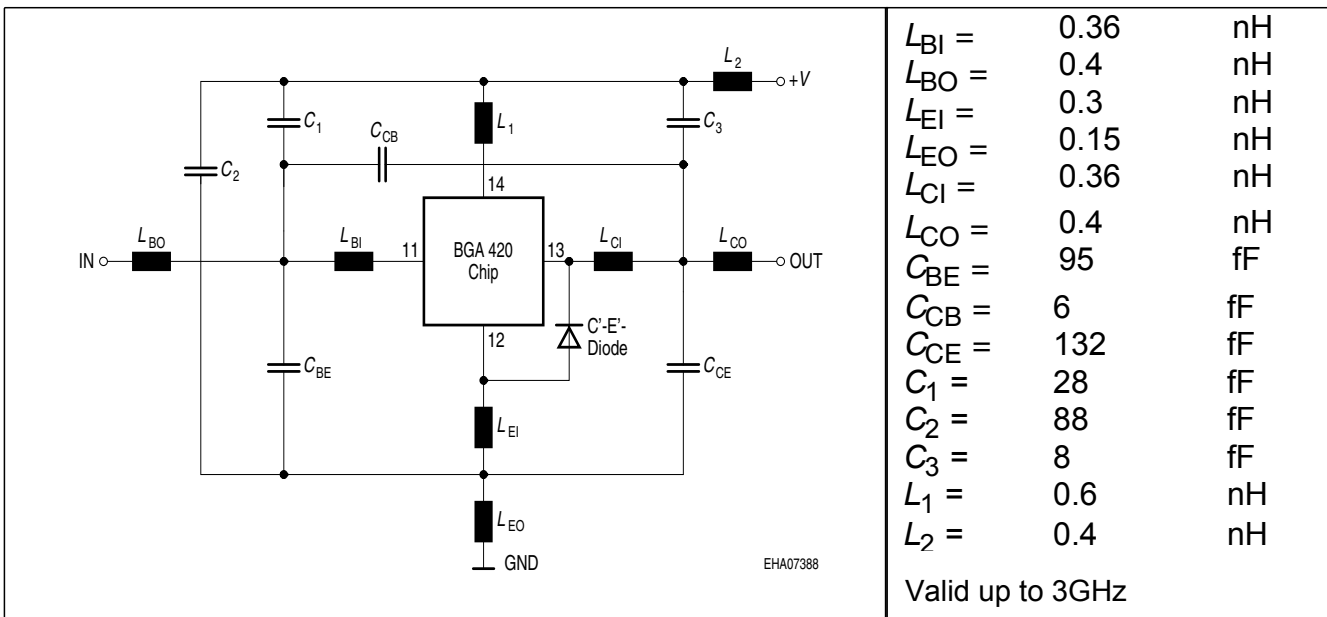

Extracted on behalf of Infineon Technologies AG by:  
 Institut für Mobil-und Satellitentechnik (IMST)

For examples and ready to use parameters please contact your local Infineon Technologies distributor or sales office to obtain a Infineon Technologies CD-ROM or see Internet:  
<http://www.infineon.com/silicondiscretes>

Insertion power gain  $|S_{21}|^2 = f(f)$

$V_D, I_D =$  parameter

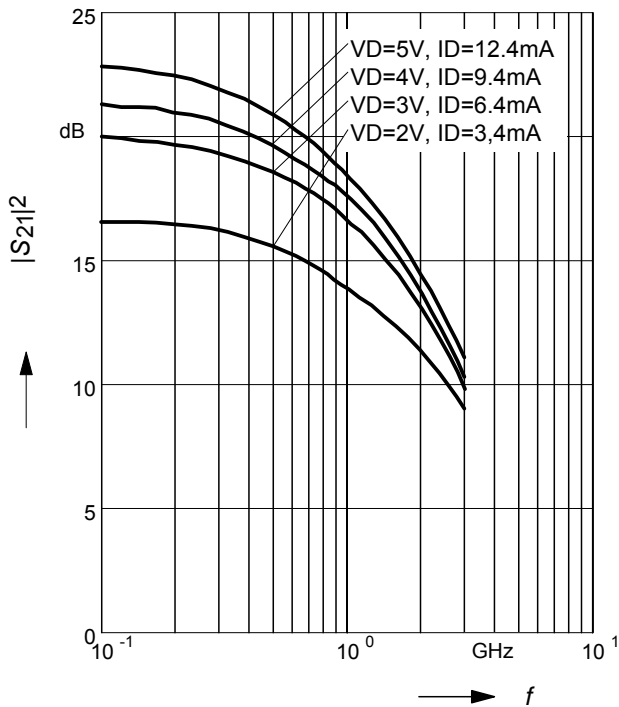

Insertion power gain  $|S_{21}|^2 = f(f)$

$V_D = 3V$

$T_A =$  parameter

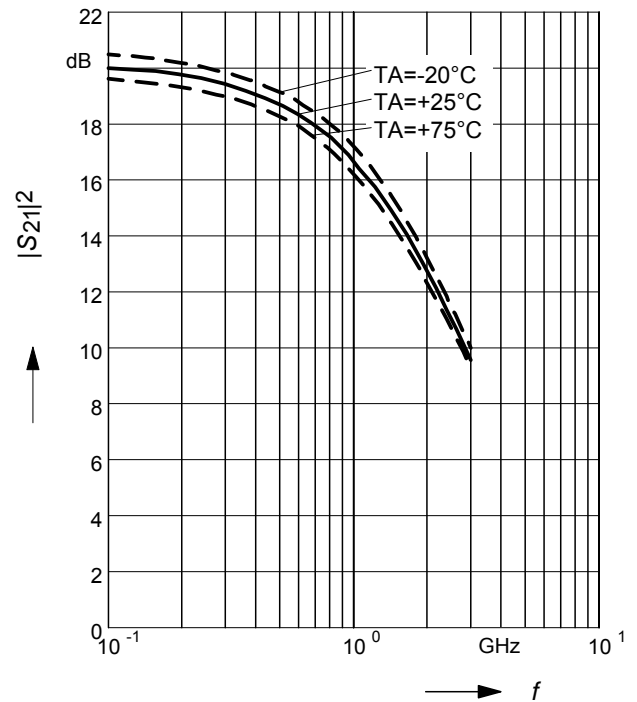

Noise figure  $NF = f(f)$

$V_D, I_D =$  parameter

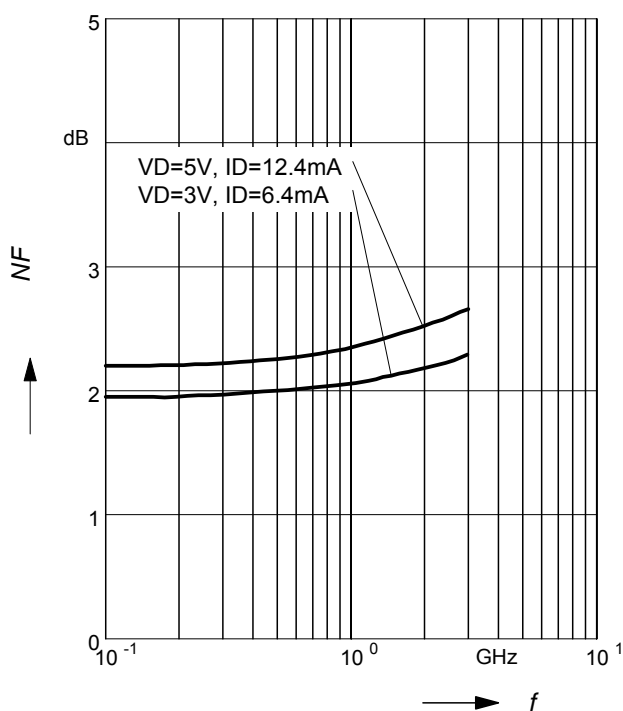

Noise figure  $NF = f(f)$

$V_D = 3V$

$T_A =$  parameter

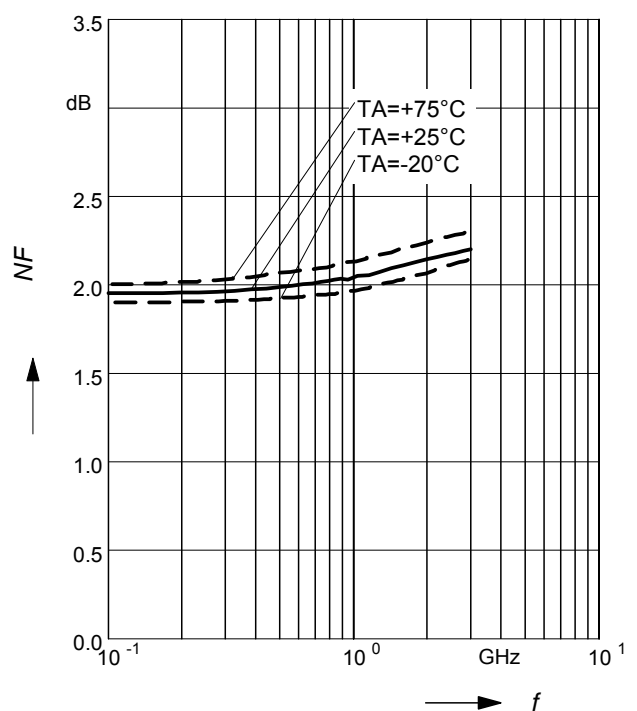

**Intercept point at the output**

$$IP_{3out} = f(f)$$

$V_D, I_D = \text{parameter}$

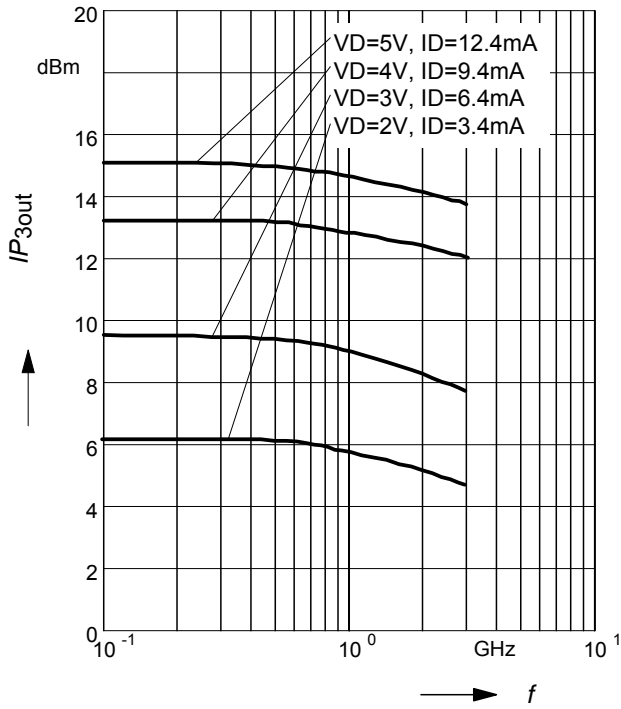

**Intercept point at the output**

$$IP_{3out} = f(f), V_D = 3V$$

$T_A = \text{parameter}$

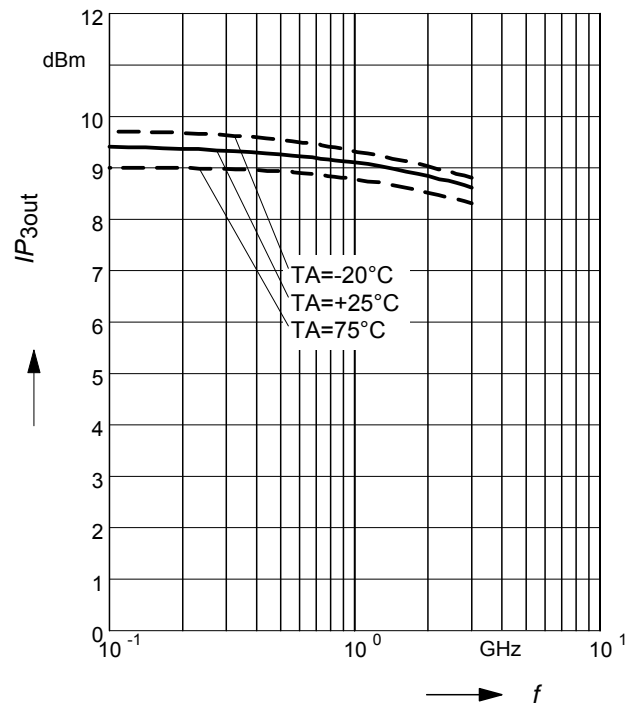

### Package Outline

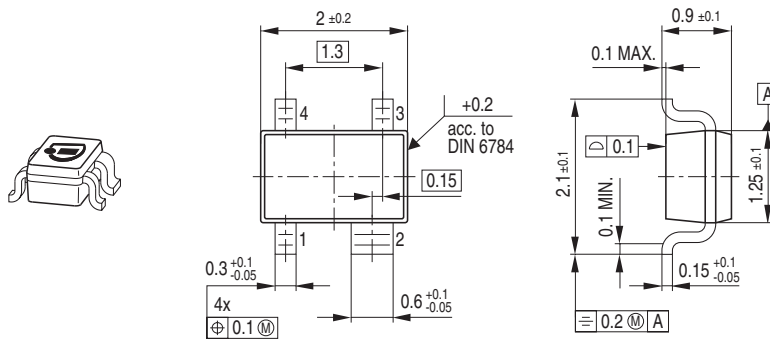

### Foot Print

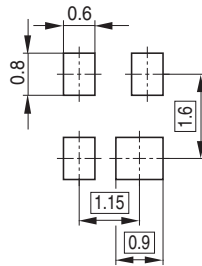

### Marking Layout

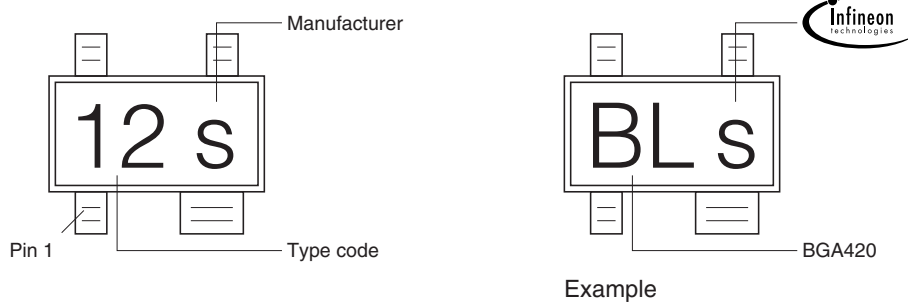

### Packing

Code E6327: Reel ø180 mm = 3.000 Pieces/Reel  
 Code E6433: Reel ø330 mm = 10.000 Pieces/Reel

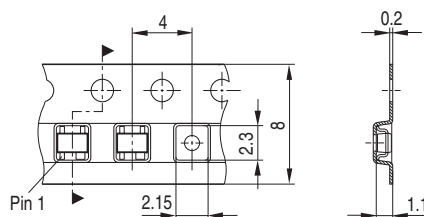

Published by Infineon Technologies AG,  
St.-Martin-Strasse 53,  
81669 München  
© Infineon Technologies AG 2005.  
All Rights Reserved.

### **Attention please!**

The information herein is given to describe certain components and shall not be considered as a guarantee of characteristics.

Terms of delivery and rights to technical change reserved.

We hereby disclaim any and all warranties, including but not limited to warranties of non-infringement, regarding circuits, descriptions and charts stated herein.

### **Information**

For further information on technology, delivery terms and conditions and prices please contact your nearest Infineon Technologies Office ([www.infineon.com](http://www.infineon.com)).

### **Warnings**

Due to technical requirements components may contain dangerous substances. For information on the types in question please contact your nearest Infineon Technologies Office.

Infineon Technologies Components may only be used in life-support devices or systems with the express written approval of Infineon Technologies, if a failure of such components can reasonably be expected to cause the failure of that life-support device or system, or to affect the safety or effectiveness of that device or system. Life support devices or systems are intended to be implanted in the human body, or to support and/or maintain and sustain and/or protect human life. If they fail, it is reasonable to assume that the health of the user or other persons may be endangered.