

Am29LV128M

128 Megabit (8 M x 16-Bit/16 M x 8-Bit) MirrorBit™ 3.0 Volt-only Uniform Sector Flash Memory with Versatile/O™ Control

DISTINCTIVE CHARACTERISTICS

ARCHITECTURAL ADVANTAGES

- **Single power supply operation**
 - 3 volt read, erase, and program operations
- **Versatile/O™ control**
 - Device generates data output voltages and tolerates data input voltages on the CE# and DQ inputs/outputs as determined by the voltage on the V_{IO} pin; operates from 1.65 to 3.6 V
- **Manufactured on 0.23 μm MirrorBit process technology**
- **SecSi™ (Secured Silicon) Sector region**
 - 128-word/256-byte sector for permanent, secure identification through an 8-word/16-byte random Electronic Serial Number, accessible through a command sequence
 - May be programmed and locked at the factory or by the customer
- **Flexible sector architecture**
 - Two hundred fifty-six 32 Kword (64 Kbyte) sectors
- **Compatibility with JEDEC standards**
 - Provides pinout and software compatibility for single-power supply flash, and superior inadvertent write protection
- **Minimum 100,000 erase cycle guarantee per sector**
- **20-year data retention at 125°C**

PERFORMANCE CHARACTERISTICS

- **High performance**
 - 100 ns access time
 - 30 ns page read times
 - 0.5 s typical sector erase time
 - 15 s typical effective write buffer word programming time: 16-word/32-byte write buffer reduces overall programming time for multiple-word updates

- 4-word/8-byte page read buffer
- 16-word/32-byte write buffer

- **Low power consumption (typical values at 3.0 V, 5 MHz)**
 - 30 mA typical active read current
 - 50 mA typical erase/program current
 - 1 μA typical standby mode current
- **Package options**
 - 56-pin TSOP
 - 64-ball Fortified BGA

SOFTWARE & HARDWARE FEATURES

- **Software features**
 - Program Suspend & Resume: read other sectors before programming operation is completed
 - Erase Suspend & Resume: read/program other sectors before an erase operation is completed
 - Data# polling & toggle bits provide status
 - Unlock Bypass Program command reduces overall multiple-word or byte programming time
 - CFI (Common Flash Interface) compliant: allows host system to identify and accommodate multiple flash devices
- **Hardware features**
 - Sector Group Protection: hardware-level method of preventing write operations within a sector group
 - Temporary Sector Group Unprotect: V_{ID}-level method of changing code in locked sector groups
 - WP#/ACC input accelerates programming time (when high voltage is applied) for greater throughput during system production. Protects first or last sector regardless of sector protection settings
 - Hardware reset input (RESET#) resets device
 - Ready/Busy# output (RY/BY#) detects program or erase cycle completion

GENERAL DESCRIPTION

The Am29LV128M is a 128 Mbit, 3.0 volt single power supply flash memory devices organized as 8,388,608 words or 16,777,216 bytes. The device has a 16-bit wide data bus that can also function as an 8-bit wide data bus by using the BYTE# input. The device can be programmed either in the host system or in standard EPROM programmers.

An access time of 90, 100, 110, or 120 ns is available. Note that each access time has a specific operating voltage range (V_{CC}) and an I/O voltage range (V_{IO}), as specified in the Product Selector Guide and the Ordering Information sections. The device is offered in a 56-pin TSOP, 64-ball Fortified BGA. Each device has separate chip enable (CE#), write enable (WE#) and output enable (OE#) controls.

Each device requires only a **single 3.0 volt power supply** for both read and write functions. In addition to a V_{CC} input, a high-voltage **accelerated program (WP#/ACC)** input provides shorter programming times through increased current. This feature is intended to facilitate factory throughput during system production, but may also be used in the field if desired.

The device is entirely command set compatible with the **JEDEC single-power-supply Flash standard**. Commands are written to the device using standard microprocessor write timing. Write cycles also internally latch addresses and data needed for the programming and erase operations.

The **sector erase architecture** allows memory sectors to be erased and reprogrammed without affecting the data contents of other sectors. The device is fully erased when shipped from the factory.

Device programming and erasure are initiated through command sequences. Once a program or erase operation has begun, the host system need only poll the DQ7 (Data# Polling) or DQ6 (toggle) **status bits** or monitor the **Ready/Busy# (RY/BY#)** output to determine whether the operation is complete. To facilitate programming, an **Unlock Bypass** mode reduces command sequence overhead by requiring only two write cycles to program data instead of four.

The **Versatile/I/O™** (V_{IO}) control allows the host system to set the voltage levels that the device generates

RELATED DOCUMENTS

For a comprehensive information on MirrorBit products, including migration information, data sheets, application notes, and software drivers, please see www.amd.com→Flash Memory→Product Information→MirrorBit→Flash Information→Technical Documentation. The following is a partial list of documents closely related to this product:

and tolerates on the CE# control input and DQ I/Os to the same voltage level that is asserted on the V_{IO} pin. Refer to the Ordering Information section for valid V_{IO} options.

Hardware data protection measures include a low V_{CC} detector that automatically inhibits write operations during power transitions. The hardware sector group protection feature disables both program and erase operations in any combination of sector groups of memory. This can be achieved in-system or via programming equipment.

The **Erase Suspend/Erase Resume** feature allows the host system to pause an erase operation in a given sector to read or program any other sector and then complete the erase operation. The **Program Suspend/Program Resume** feature enables the host system to pause a program operation in a given sector to read any other sector and then complete the program operation.

The **hardware RESET# pin** terminates any operation in progress and resets the device, after which it is then ready for a new operation. The RESET# pin may be tied to the system reset circuitry. A system reset would thus also reset the device, enabling the host system to read boot-up firmware from the Flash memory device.

The device reduces power consumption in the **standby mode** when it detects specific voltage levels on CE# and RESET#, or when addresses have been stable for a specified period of time.

The **SecSi™ (Secured Silicon) Sector** provides a 128-word/256-byte area for code or data that can be permanently protected. Once this sector is protected, no further changes within the sector can occur.

The **Write Protect (WP#/ACC)** feature protects the first or last sector by asserting a logic low on the WP# pin.

AMD MirrorBit flash technology combines years of Flash memory manufacturing experience to produce the highest levels of quality, reliability and cost effectiveness. The device electrically erases all bits within a sector simultaneously via hot-hole assisted erase. The data is programmed using hot electron injection.

MirrorBit™ Flash Memory Write Buffer Programming and Page Buffer Read

Implementing a Common Layout for AMD MirrorBit and Intel StrataFlash Memory Devices

Migrating from Single-byte to Three-byte Device IDs

Am29LV256M, 256 Mbit MirrorBit Flash device (in 64-ball, 18 x 12 mm Fortified BGA package)

TABLE OF CONTENTS

Product Selector Guide	4	Erase Suspend/Erase Resume Commands	33
Block Diagram	4	Command Definitions	34
Connection Diagrams	5	Table 10. Command Definitions (x16 Mode, BYTE# = V _{IH})	34
Pin Description	7	Table 11. Command Definitions (x8 Mode, BYTE# = V _{IL})	35
Logic Symbol	7	Write Operation Status	36
Ordering Information	8	DQ7: Data# Polling	36
Device Bus Operations	9	Figure 8. Data# Polling Algorithm	36
Table 1. Device Bus Operations	9	RY/BY#: Ready/Busy#	37
Word/Byte Configuration	9	DQ6: Toggle Bit I	37
VersatileIO™ (V _{IO}) Control	9	Figure 9. Toggle Bit Algorithm	38
Requirements for Reading Array Data	10	DQ2: Toggle Bit II	38
Page Mode Read	10	Reading Toggle Bits DQ6/DQ2	38
Writing Commands/Command Sequences	10	DQ5: Exceeded Timing Limits	39
Write Buffer	10	DQ3: Sector Erase Timer	39
Accelerated Program Operation	10	DQ1: Write-to-Buffer Abort	39
Autoselect Functions	10	Table 12. Write Operation Status	40
Standby Mode	10	Absolute Maximum Ratings	41
Automatic Sleep Mode	11	Figure 10. Maximum Negative Overshoot Waveform	41
RESET#: Hardware Reset Pin	11	Figure 11. Maximum Positive Overshoot Waveform	41
Output Disable Mode	11	Operating Ranges	41
Table 2. Sector Address Table	12	DC Characteristics	42
Autoselect Mode	18	Test Conditions	43
Table 3. Autoselect Codes, (High Voltage Method)	18	Figure 12. Test Setup	43
Sector Group Protection and Unprotection	19	Table 13. Test Specifications	43
Table 4. Sector Group Protection/Unprotection Address Table	19	Key to Switching Waveforms	43
Write Protect (WP#)	20	Figure 13. Input Waveforms and Measurement Levels	43
Temporary Sector Group Unprotect	20	AC Characteristics	44
Figure 1. Temporary Sector Group Unprotect Operation	20	Read-Only Operations	44
Figure 2. In-System Sector Group Protect/Unprotect Algorithms	21	Figure 14. Read Operation Timings	44
SecSi (Secured Silicon) Sector Flash Memory Region	22	Figure 15. Page Read Timings	45
Table 5. SecSi Sector Contents	22	Hardware Reset (RESET#)	46
Figure 3. SecSi Sector Protect Verify	23	Figure 16. Reset Timings	46
Hardware Data Protection	23	Erase and Program Operations	47
Low VCC Write Inhibit	23	Figure 17. Reset Timings	48
Write Pulse “Glitch” Protection	23	Figure 18. Program Operation Timings	49
Logical Inhibit	23	Figure 19. Accelerated Program Timing Diagram	49
Power-Up Write Inhibit	23	Figure 20. Chip/Sector Erase Operation Timings	50
Common Flash Memory Interface (CFI)	23	Figure 21. Data# Polling Timings (During Embedded Algorithms)	51
Table 6. CFI Query Identification String	24	Figure 22. Toggle Bit Timings (During Embedded Algorithms)	52
Table 7. System Interface String	24	Figure 23. DQ2 vs. DQ6	52
Table 8. Device Geometry Definition	25	Temporary Sector Group Unprotect	53
Table 9. Primary Vendor-Specific Extended Query	26	Figure 24. Temporary Sector Group Unprotect Timing Diagram	53
Command Definitions	27	Figure 25. Sector Group Protect and Unprotect Timing Diagram	54
Reading Array Data	27	Alternate CE# Controlled Erase and Program Operations	55
Reset Command	27	Figure 26. Alternate CE# Controlled Write (Erase/Program)	
Autoselect Command Sequence	27	Operation Timings	56
Enter SecSi Sector/Exit SecSi Sector Command Sequence	28	Latchup Characteristics	56
Word/Byte Program Command Sequence	28	Erase And Programming Performance	57
Unlock Bypass Command Sequence	28	TSOP Pin and BGA Package Capacitance	57
Write Buffer Programming	28	Data Retention	57
Accelerated Program	29	Physical Dimensions	58
Figure 4. Write Buffer Programming Operation	30	TS056/TSR056—56-Pin Standard/Reverse Thin Small Outline	
Figure 5. Program Operation	31	Package (TSOP)	58
Program Suspend/Program Resume Command Sequence	31	LAA064—64-Ball Fortified Ball Grid Array	
Figure 6. Program Suspend/Program Resume	32	13 x 11 mm Package	59
Chip Erase Command Sequence	32	Revision Summary	60
Sector Erase Command Sequence	32		
Figure 7. Erase Operation	33		

PRODUCT SELECTOR GUIDE

Part Number		Am29LV128M				
Speed/ Voltage Option	Regulated Voltage Range $V_{CC} = 3.0-3.6\text{ V}$	103R $V_{IO} = 2.7-3.6\text{ V}$	113R $V_{IO} = 1.65-3.6\text{ V}$		123R $V_{IO} = 1.65-3.6\text{ V}$	
	Full Voltage Range $V_{CC} = 2.7-3.6\text{ V}$	103 (Note 2) $V_{IO} = 2.7-3.6\text{ V}$		113 $V_{IO} = 1.65-3.6\text{ V}$		123 $V_{IO} = 1.65-3.6\text{ V}$
Max. Access Time (ns)		100	110		120	
Max. CE# Access Time (ns)		100	110		120	
Max. Page access time (t_{PACC})		30	30	40	30	40
Max. OE# Access Time (ns)		30	30	40	30	40

Notes:

1. See "AC Characteristics" for full specifications.
2. Contact factory for availability and ordering information.

BLOCK DIAGRAM

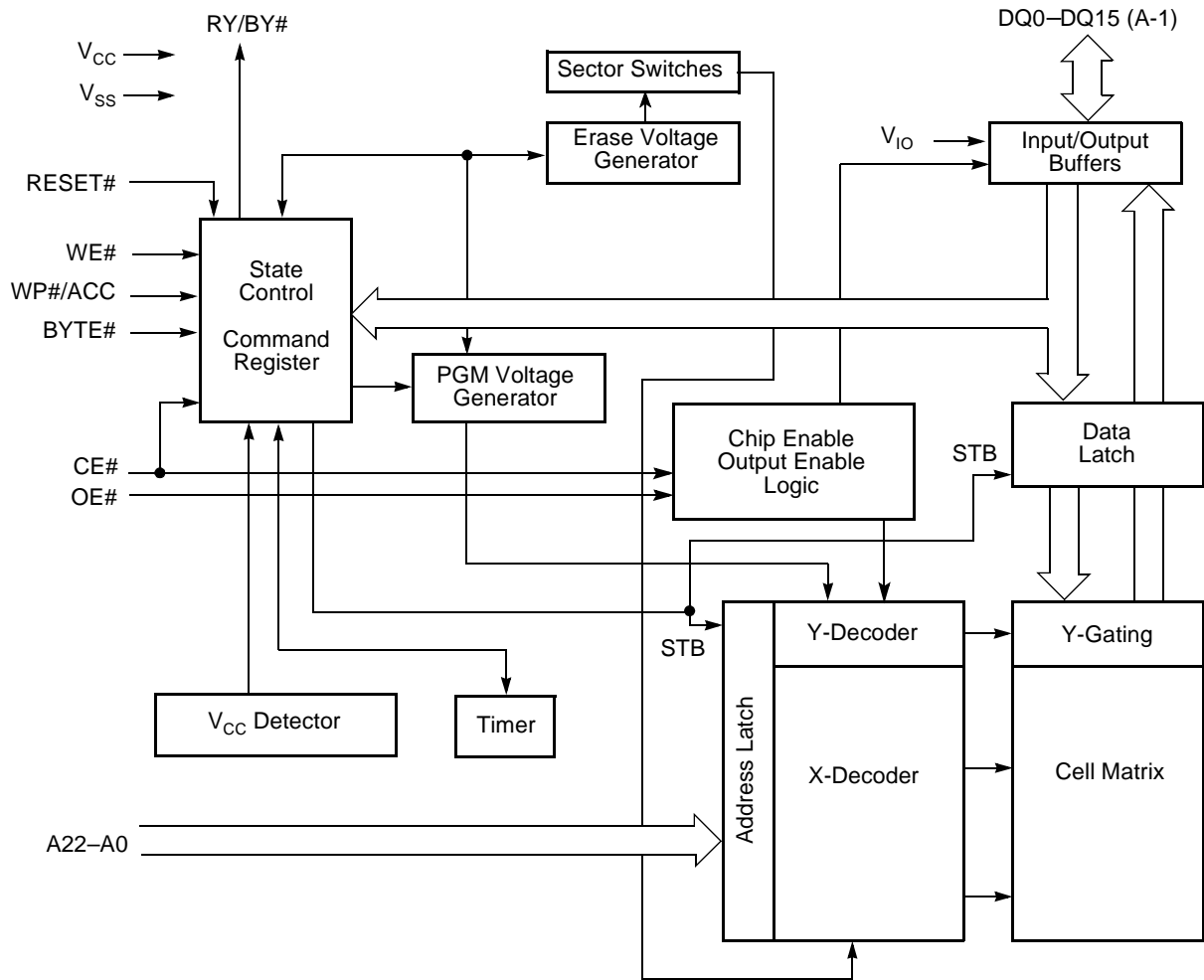

CONNECTION DIAGRAMS

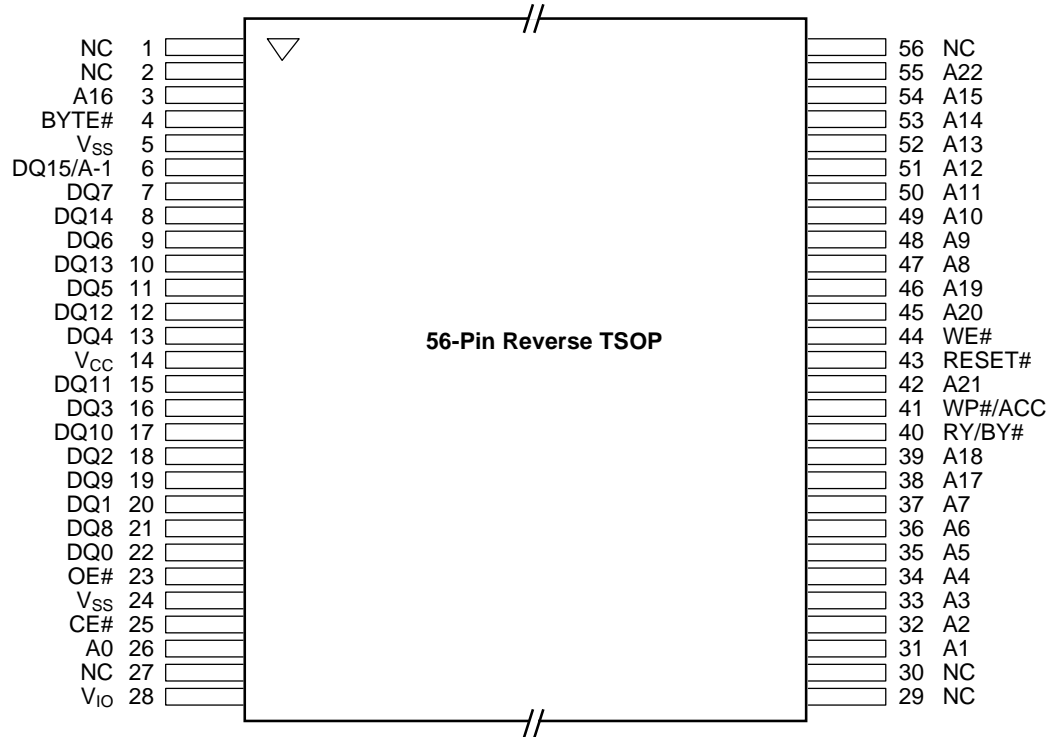
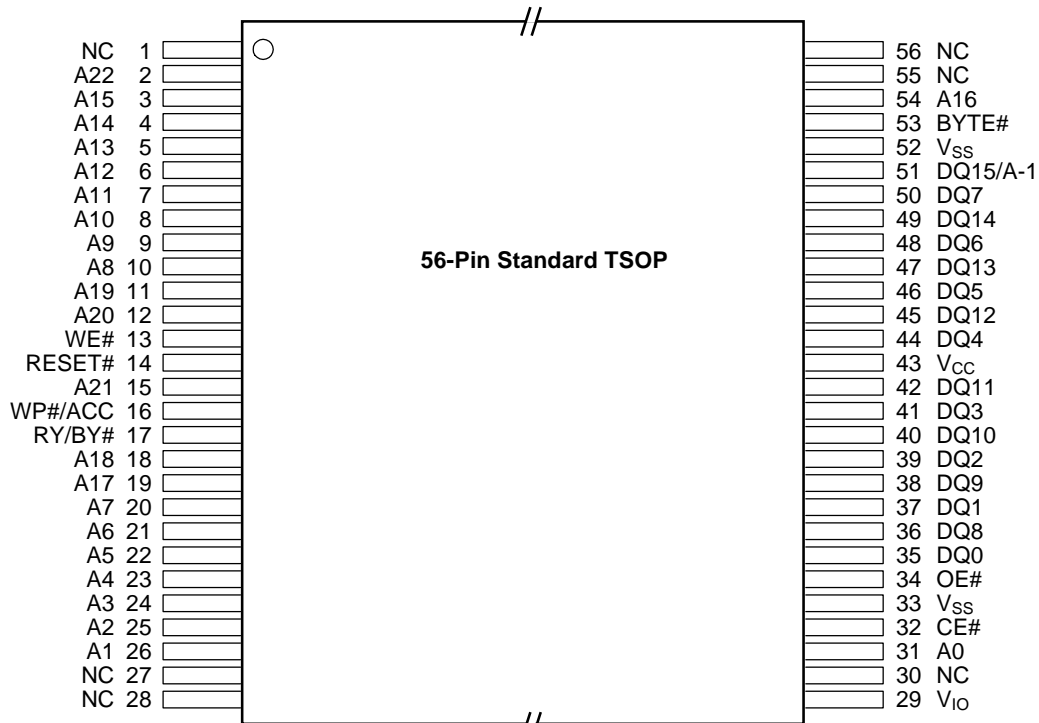

CONNECTION DIAGRAMS

64- Ball Fortified BGA
Top View, Balls Facing Down

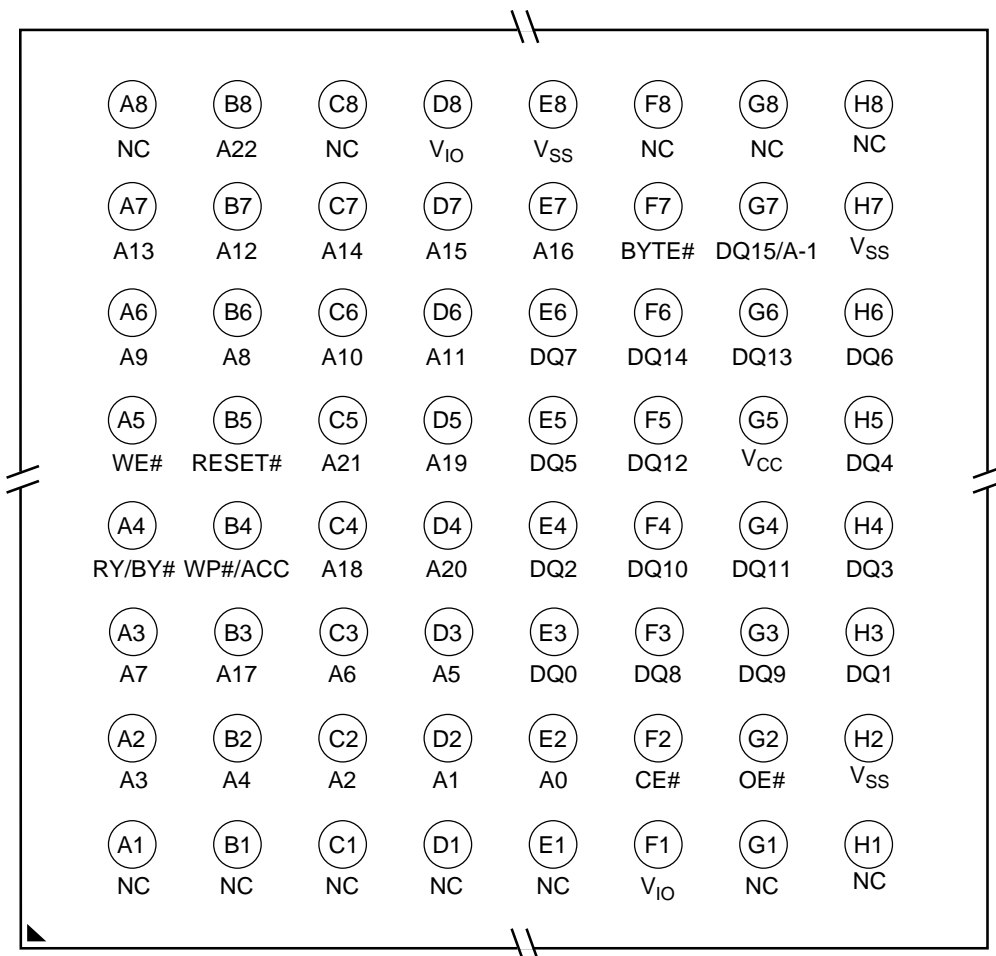

Special Package Handling Instructions

Special handling is required for Flash Memory products in molded packages (TSOP and BGA). The package and/or data integrity may be compromised if the

package body is exposed to temperatures above 150°C for prolonged periods of time.

PIN DESCRIPTION

- A22–A0 = 23 Address inputs
- DQ14–DQ0 = 15 Data inputs/outputs
- DQ15/A-1 = DQ15 (Data input/output, word mode),
A-1 (LSB Address input, byte mode)
- CE# = Chip Enable input
- OE# = Output Enable input
- WE# = Write Enable input
- WP#/ACC = Hardware Write Protect input;
Acceleration input
- RESET# = Hardware Reset Pin input
- BYTE# = Selects 8-bit or 16-bit mode
- RY/BY# = Ready/Busy output
- V_{CC} = 3.0 volt-only single power supply
(see Product Selector Guide for
speed options and voltage
supply tolerances)
- V_{IO} = Output Buffer power
- V_{SS} = Device Ground
- NC = Pin Not Connected Internally

LOGIC SYMBOL

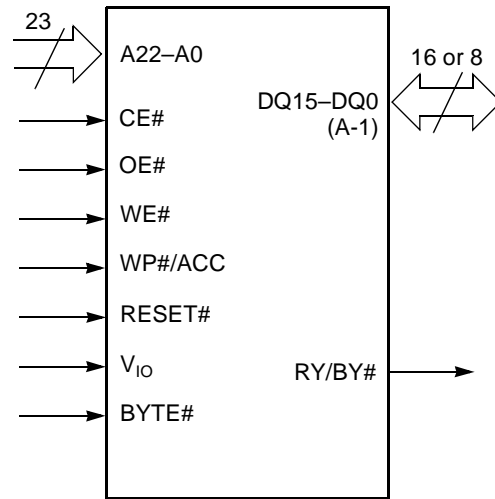

ORDERING INFORMATION

Standard Products

AMD standard products are available in several packages and operating ranges. The order number (Valid Combination) is formed by a combination of the following:

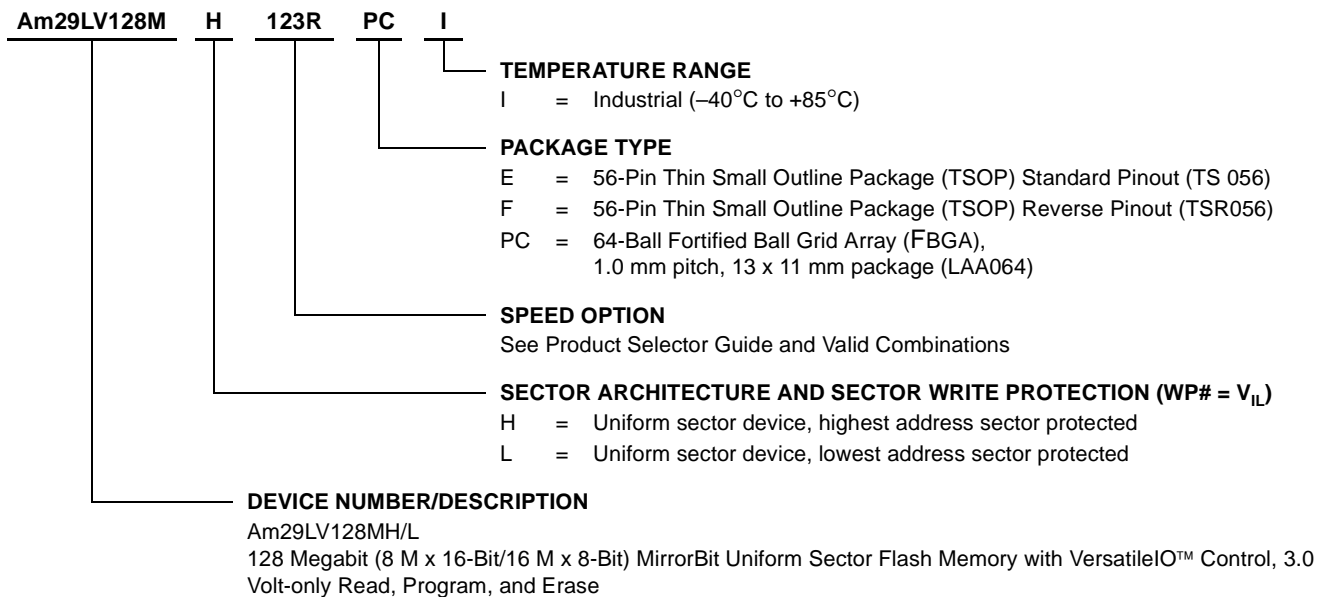

Valid Combinations for TSOP Package	Speed (ns)	V _{IO} Range	V _{CC} Range
Am29LV128MH113 Am29LV128ML113	110	1.65–3.6 V	2.7–3.6 V
Am29LV128MH123 Am29LV128ML123	120	1.65–3.6 V	
Am29LV128MH103R Am29LV128ML103R	100	2.7–3.6 V	3.0–3.6 V
Am29LV128MH113R Am29LV128ML113R	110	1.65–3.6 V	
Am29LV128MH123R Am29LV128ML123R	120	1.65–3.6 V	

Valid Combinations

Valid Combinations list configurations planned to be supported in volume for this device. Consult the local AMD sales office to confirm availability of specific valid combinations and to check on newly released combinations.

Valid Combinations for Fortified BGA Package			Speed (ns)	V _{IO} Range	V _{CC} Range
Order Number	Package Marking				
Am29LV128MH113 Am29LV128ML113	PCI	L128MH113P L128ML113P	110	1.65–3.6 V	2.7–3.6 V
Am29LV128MH123 Am29LV128ML123		L128MH123P L128ML123P	120	1.65–3.6 V	
Am29LV128MH103R Am29LV128ML103R		L128MH103N L128ML103N	100	2.7–3.6 V	3.0–3.6 V
Am29LV128MH113R Am29LV128ML113R		L128MH113N L128ML113N	110	1.65–3.6 V	
Am29LV128MH123R Am29LV128ML123R		L128MH123N L128ML123N	120	1.65–3.6 V	

Note: For 103 speed option shown in product selector guide, contact AMD for availability and ordering information.

DEVICE BUS OPERATIONS

This section describes the requirements and use of the device bus operations, which are initiated through the internal command register. The command register itself does not occupy any addressable memory location. The register is a latch used to store the commands, along with the address and data information needed to execute the command. The contents of the

register serve as inputs to the internal state machine. The state machine outputs dictate the function of the device. Table 1 lists the device bus operations, the inputs and control levels they require, and the resulting output. The following subsections describe each of these operations in further detail.

Table 1. Device Bus Operations

Operation	CE#	OE#	WE#	RESET#	WP#	ACC	Addresses (Note 2)	DQ0– DQ7	DQ8–DQ15	
									BYTE# = V _{IH}	BYTE# = V _{IL}
Read	L	L	H	H	X	X	A _{IN}	D _{OUT}	D _{OUT}	DQ8–DQ14 = High-Z, DQ15 = A-1
Write (Program/Erase)	L	H	L	H	(Note 3)	X	A _{IN}	(Note 4)	(Note 4)	
Accelerated Program	L	H	L	H	(Note 3)	V _{HH}	A _{IN}	(Note 4)	(Note 4)	
Standby	V _{CC} ± 0.3 V	X	X	V _{CC} ± 0.3 V	X	H	X	High-Z	High-Z	High-Z
Output Disable	L	H	H	H	X	X	X	High-Z	High-Z	High-Z
Reset	X	X	X	L	X	X	X	High-Z	High-Z	High-Z
Sector Group Protect (Note 2)	L	H	L	V _{ID}	H	X	SA, A6=L, A3=L, A2=L, A1=H, A0=L	(Note 4)	X	X
Sector Group Unprotect (Note 2)	L	H	L	V _{ID}	H	X	SA, A6=H, A3=L, A2=L, A1=H, A0=L	(Note 4)	X	X
Temporary Sector Group Unprotect	X	X	X	V _{ID}	H	X	A _{IN}	(Note 4)	(Note 4)	High-Z

Legend: L = Logic Low = V_{IL}, H = Logic High = V_{IH}, V_{ID} = 11.5–12.5 V, V_{HH} = 11.5–12.5 V, X = Don't Care, SA = Sector Address, A_{IN} = Address In, D_{IN} = Data In, D_{OUT} = Data Out

Notes:

- Addresses are A22:A0 in word mode; A22:A-1 in byte mode. Sector addresses are A22:A15 in both modes.
- The sector group protect and sector group unprotect functions may also be implemented via programming equipment. See the "Sector Group Protection and Unprotection" section.
- If WP# = V_{IL}, the first or last sector remains protected. If WP# = V_{IH}, the first or last sector will be protected or unprotected as determined by the method described in "Write Protect (WP#)". All sectors are unprotected when shipped from the factory (The SecSi Sector may be factory protected depending on version ordered.)
- D_{IN} or D_{OUT} as required by command sequence, data polling, or sector protect algorithm (see Figure 2).

Word/Byte Configuration

The BYTE# pin controls whether the device data I/O pins operate in the byte or word configuration. If the BYTE# pin is set at logic '1', the device is in word configuration, DQ0–DQ15 are active and controlled by CE# and OE#.

If the BYTE# pin is set at logic '0', the device is in byte configuration, and only data I/O pins DQ0–DQ7 are active and controlled by CE# and OE#. The data I/O

pins DQ8–DQ14 are tri-stated, and the DQ15 pin is used as an input for the LSB (A-1) address function.

VersatileIO™ (V_{IO}) Control

The VersatileIO™ (V_{IO}) control allows the host system to set the voltage levels that the device generates and tolerates on CE# and DQ I/Os to the same voltage level that is asserted on V_{IO}. See Ordering Information for V_{IO} options on this device.

Requirements for Reading Array Data

To read array data from the outputs, the system must drive the CE# and OE# pins to V_{IL} . CE# is the power control and selects the device. OE# is the output control and gates array data to the output pins. WE# should remain at V_{IH} .

The internal state machine is set for reading array data upon device power-up, or after a hardware reset. This ensures that no spurious alteration of the memory content occurs during the power transition. No command is necessary in this mode to obtain array data. Standard microprocessor read cycles that assert valid addresses on the device address inputs produce valid data on the device data outputs. The device remains enabled for read access until the command register contents are altered.

See “Reading Array Data” for more information. Refer to the AC Read-Only Operations table for timing specifications and to Figure 14 for the timing diagram. Refer to the DC Characteristics table for the active current specification on reading array data.

Page Mode Read

The device is capable of fast page mode read and is compatible with the page mode Mask ROM read operation. This mode provides faster read access speed for random locations within a page. The page size of the device is 4 words/8 bytes. The appropriate page is selected by the higher address bits A(max)–A2. Address bits A1–A0 in word mode (A1–A-1 in byte mode) determine the specific word within a page. This is an asynchronous operation; the microprocessor supplies the specific word location.

The random or initial page access is equal to t_{ACC} or t_{CE} and subsequent page read accesses (as long as the locations specified by the microprocessor falls within that page) is equivalent to t_{PACC} . When CE# is deasserted and reasserted for a subsequent access, the access time is t_{ACC} or t_{CE} . Fast page mode accesses are obtained by keeping the “read-page addresses” constant and changing the “intra-read page” addresses.

Writing Commands/Command Sequences

To write a command or command sequence (which includes programming data to the device and erasing sectors of memory), the system must drive WE# and CE# to V_{IL} , and OE# to V_{IH} .

The device features an **Unlock Bypass** mode to facilitate faster programming. Once the device enters the Unlock Bypass mode, only two write cycles are required to program a word or byte, instead of four. The “Word/Byte Program Command Sequence” section has details on programming data to the device using

both standard and Unlock Bypass command sequences.

An erase operation can erase one sector, multiple sectors, or the entire device. Table 2 indicates the address space that each sector occupies.

Refer to the DC Characteristics table for the active current specification for the write mode. The AC Characteristics section contains timing specification tables and timing diagrams for write operations.

Write Buffer

Write Buffer Programming allows the system write to a maximum of 16 words/32 bytes in one programming operation. This results in faster effective programming time than the standard programming algorithms. See “Write Buffer” for more information.

Accelerated Program Operation

The device offers accelerated program operations through the ACC function. This is one of two functions provided by the WP#/ACC pin. This function is primarily intended to allow faster manufacturing throughput at the factory.

If the system asserts V_{HH} on this pin, the device automatically enters the aforementioned Unlock Bypass mode, temporarily unprotects any protected sector groups, and uses the higher voltage on the pin to reduce the time required for program operations. The system would use a two-cycle program command sequence as required by the Unlock Bypass mode. Removing V_{HH} from the WP#/ACC pin returns the device to normal operation. *Note that the WP#/ACC pin must not be at V_{HH} for operations other than accelerated programming, or device damage may result. WP# has an internal pullup; when unconnected, WP# is at V_{IH} .*

Autoselect Functions

If the system writes the autoselect command sequence, the device enters the autoselect mode. The system can then read autoselect codes from the internal register (which is separate from the memory array) on DQ7–DQ0. Standard read cycle timings apply in this mode. Refer to the Autoselect Mode and Autoselect Command Sequence sections for more information.

Standby Mode

When the system is not reading or writing to the device, it can place the device in the standby mode. In this mode, current consumption is greatly reduced, and the outputs are placed in the high impedance state, independent of the OE# input.

The device enters the CMOS standby mode when the CE# and RESET# pins are both held at $V_{IO} \pm 0.3 V$. (Note that this is a more restricted voltage range than

V_{IH} .) If CE# and RESET# are held at V_{IH} , but not within $V_{IO} \pm 0.3$ V, the device will be in the standby mode, but the standby current will be greater. The device requires standard access time (t_{CE}) for read access when the device is in either of these standby modes, before it is ready to read data.

If the device is deselected during erasure or programming, the device draws active current until the operation is completed.

Refer to the DC Characteristics table for the standby current specification.

Automatic Sleep Mode

The automatic sleep mode minimizes Flash device energy consumption. The device automatically enables this mode when addresses remain stable for $t_{ACC} + 30$ ns. The automatic sleep mode is independent of the CE#, WE#, and OE# control signals. Standard address access timings provide new data when addresses are changed. While in sleep mode, output data is latched and always available to the system. Refer to the DC Characteristics table for the automatic sleep mode current specification.

RESET#: Hardware Reset Pin

The RESET# pin provides a hardware method of resetting the device to reading array data. When the RE-

SET# pin is driven low for at least a period of t_{RP} , the device immediately terminates any operation in progress, tristates all output pins, and ignores all read/write commands for the duration of the RESET# pulse. The device also resets the internal state machine to reading array data. The operation that was interrupted should be reinitiated once the device is ready to accept another command sequence, to ensure data integrity.

Current is reduced for the duration of the RESET# pulse. When RESET# is held at $V_{SS} \pm 0.3$ V, the device draws CMOS standby current (I_{CC4}). If RESET# is held at V_{IL} but not within $V_{SS} \pm 0.3$ V, the standby current will be greater.

The RESET# pin may be tied to the system reset circuitry. A system reset would thus also reset the Flash memory, enabling the system to read the boot-up firmware from the Flash memory.

Refer to the AC Characteristics tables for RESET# parameters and to Figure 16 for the timing diagram.

Output Disable Mode

When the OE# input is at V_{IH} , output from the device is disabled. The output pins are placed in the high impedance state.

Table 2. Sector Address Table

Sector	A22–A15								Sector Size (Kbytes/Kwords)	8-bit Address Range (in hexadecimal)	16-bit Address Range (in hexadecimal)
	0	0	0	0	0	0	0	0			
SA0	0	0	0	0	0	0	0	0	64/32	000000–00FFFF	000000–007FFF
SA1	0	0	0	0	0	0	0	1	64/32	010000–01FFFF	008000–00FFFF
SA2	0	0	0	0	0	0	1	0	64/32	020000–02FFFF	010000–017FFF
SA3	0	0	0	0	0	0	1	1	64/32	030000–03FFFF	018000–01FFFF
SA4	0	0	0	0	0	1	0	0	64/32	040000–04FFFF	020000–027FFF
SA5	0	0	0	0	0	1	0	1	64/32	050000–05FFFF	028000–02FFFF
SA6	0	0	0	0	0	1	1	0	64/32	060000–06FFFF	030000–037FFF
SA7	0	0	0	0	0	1	1	1	64/32	070000–07FFFF	038000–03FFFF
SA8	0	0	0	0	1	0	0	0	64/32	080000–08FFFF	040000–047FFF
SA9	0	0	0	0	1	0	0	1	64/32	090000–09FFFF	048000–04FFFF
SA10	0	0	0	0	1	0	1	0	64/32	0A0000–0AFFFF	050000–057FFF
SA11	0	0	0	0	1	0	1	1	64/32	0B0000–0BFFFF	058000–05FFFF
SA12	0	0	0	0	1	1	0	0	64/32	0C0000–0CFFFF	060000–067FFF
SA13	0	0	0	0	1	1	0	1	64/32	0D0000–0DFFFF	068000–06FFFF
SA14	0	0	0	0	1	1	1	0	64/32	0E0000–0EFFFF	070000–077FFF
SA15	0	0	0	0	1	1	1	1	64/32	0F0000–0FFFFF	078000–07FFFF
SA16	0	0	0	1	0	0	0	0	64/32	100000–10FFFF	080000–087FFF
SA17	0	0	0	1	0	0	0	1	64/32	110000–11FFFF	088000–08FFFF
SA18	0	0	0	1	0	0	1	0	64/32	120000–12FFFF	090000–097FFF
SA19	0	0	0	1	0	0	1	1	64/32	130000–13FFFF	098000–09FFFF
SA20	0	0	0	1	0	1	0	0	64/32	140000–14FFFF	0A0000–0A7FFF
SA21	0	0	0	1	0	1	0	1	64/32	150000–15FFFF	0A8000–0AFFFF
SA22	0	0	0	1	0	1	1	0	64/32	160000–16FFFF	0B0000–0B7FFF
SA23	0	0	0	1	0	1	1	1	64/32	170000–17FFFF	0B8000–0BFFFF
SA24	0	0	0	1	1	0	0	0	64/32	180000–18FFFF	0C0000–0C7FFF
SA25	0	0	0	1	1	0	0	1	64/32	190000–19FFFF	0C8000–0CFFFF
SA26	0	0	0	1	1	0	1	0	64/32	1A0000–1AFFFF	0D0000–0D7FFF
SA27	0	0	0	1	1	0	1	1	64/32	1B0000–1BFFFF	0D8000–0DFFFF
SA28	0	0	0	1	1	1	0	0	64/32	1C0000–1CFFFF	0E0000–0E7FFF
SA29	0	0	0	1	1	1	0	1	64/32	1D0000–1DFFFF	0E8000–0EFFFF
SA30	0	0	0	1	1	1	1	0	64/32	1E0000–1EFFFF	0F0000–0F7FFF
SA31	0	0	0	1	1	1	1	1	64/32	1F0000–1FFFFF	0F8000–0FFFFF
SA32	0	0	1	0	0	0	0	0	64/32	200000–20FFFF	100000–107FFF
SA33	0	0	1	0	0	0	0	1	64/32	210000–21FFFF	108000–10FFFF
SA34	0	0	1	0	0	0	1	0	64/32	220000–22FFFF	110000–117FFF
SA35	0	0	1	0	0	0	1	1	64/32	230000–23FFFF	118000–11FFFF
SA36	0	0	1	0	0	1	0	0	64/32	240000–24FFFF	120000–127FFF
SA37	0	0	1	0	0	1	0	1	64/32	250000–25FFFF	128000–12FFFF
SA38	0	0	1	0	0	1	1	0	64/32	260000–26FFFF	130000–137FFF
SA39	0	0	1	0	0	1	1	1	64/32	270000–27FFFF	138000–13FFFF
SA40	0	0	1	0	1	0	0	0	64/32	280000–28FFFF	140000–147FFF
SA41	0	0	1	0	1	0	0	1	64/32	290000–29FFFF	148000–14FFFF
SA42	0	0	1	0	1	0	1	0	64/32	2A0000–2AFFFF	150000–157FFF
SA43	0	0	1	0	1	0	1	1	64/32	2B0000–2BFFFF	158000–15FFFF
SA44	0	0	1	0	1	1	0	0	64/32	2C0000–2CFFFF	160000–167FFF
SA45	0	0	1	0	1	1	0	1	64/32	2D0000–2DFFFF	168000–16FFFF
SA46	0	0	1	0	1	1	1	0	64/32	2E0000–2EFFFF	170000–177FFF

Table 2. Sector Address Table (Continued)

Sector	A22-A15								Sector Size (Kbytes/Kwords)	8-bit Address Range (in hexadecimal)	16-bit Address Range (in hexadecimal)
	0	0	1	0	1	1	1	1			
SA47	0	0	1	0	1	1	1	1	64/32	2F0000-2FFFFFFF	178000-17FFFF
SA48	0	0	1	1	0	0	0	0	64/32	300000-30FFFF	180000-187FFF
SA49	0	0	1	1	0	0	0	1	64/32	310000-31FFFF	188000-18FFFF
SA50	0	0	1	1	0	0	1	0	64/32	320000-32FFFF	190000-197FFF
SA51	0	0	1	1	0	0	1	1	64/32	330000-33FFFF	198000-19FFFF
SA52	0	0	1	1	0	1	0	0	64/32	340000-34FFFF	1A0000-1A7FFF
SA53	0	0	1	1	0	1	0	1	64/32	350000-35FFFF	1A8000-1AFFFF
SA54	0	0	1	1	0	1	1	0	64/32	360000-36FFFF	1B0000-1B7FFF
SA55	0	0	1	1	0	1	1	1	64/32	370000-37FFFF	1B8000-1BFFFF
SA56	0	0	1	1	1	0	0	0	64/32	380000-38FFFF	1C0000-1C7FFF
SA57	0	0	1	1	1	0	0	1	64/32	390000-39FFFF	1C8000-1CFFFF
SA58	0	0	1	1	1	0	1	0	64/32	3A0000-3AFFFF	1D0000-1D7FFF
SA59	0	0	1	1	1	0	1	1	64/32	3B0000-3BFFFF	1D8000-1DFFFF
SA60	0	0	1	1	1	1	0	0	64/32	3C0000-3CFFFF	1E0000-1E7FFF
SA61	0	0	1	1	1	1	0	1	64/32	3D0000-3DFFFF	1E8000-1EFFFF
SA62	0	0	1	1	1	1	1	0	64/32	3E0000-3EFFFF	1F0000-1F7FFF
SA63	0	0	1	1	1	1	1	1	64/32	3F0000-3FFFFFFF	1F8000-1FFFFFFF
SA64	0	1	0	0	0	0	0	0	64/32	400000-40FFFF	200000-207FFF
SA65	0	1	0	0	0	0	0	1	64/32	410000-41FFFF	208000-20FFFF
SA66	0	1	0	0	0	0	1	0	64/32	420000-42FFFF	210000-217FFF
SA67	0	1	0	0	0	0	1	1	64/32	430000-43FFFF	218000-21FFFF
SA68	0	1	0	0	0	1	0	0	64/32	440000-44FFFF	220000-227FFF
SA69	0	1	0	0	0	1	0	1	64/32	450000-45FFFF	228000-22FFFF
SA70	0	1	0	0	0	1	1	0	64/32	460000-46FFFF	230000-237FFF
SA71	0	1	0	0	0	1	1	1	64/32	470000-47FFFF	238000-23FFFF
SA72	0	1	0	0	1	0	0	0	64/32	480000-48FFFF	240000-247FFF
SA73	0	1	0	0	1	0	0	1	64/32	490000-49FFFF	248000-24FFFF
SA74	0	1	0	0	1	0	1	0	64/32	4A0000-4AFFFF	250000-257FFF
SA75	0	1	0	0	1	0	1	1	64/32	4B0000-4BFFFF	258000-25FFFF
SA76	0	1	0	0	1	1	0	0	64/32	4C0000-4CFFFF	260000-267FFF
SA77	0	1	0	0	1	1	0	1	64/32	4D0000-4DFFFF	268000-26FFFF
SA78	0	1	0	0	1	1	1	0	64/32	4E0000-4EFFFF	270000-277FFF
SA79	0	1	0	0	1	1	1	1	64/32	4F0000-4FFFFFFF	278000-27FFFF
SA80	0	1	0	1	0	0	0	0	64/32	500000-50FFFF	280000-287FFF
SA81	0	1	0	1	0	0	0	1	64/32	510000-51FFFF	288000-28FFFF
SA82	0	1	0	1	0	0	1	0	64/32	520000-52FFFF	290000-297FFF
SA83	0	1	0	1	0	0	1	1	64/32	530000-53FFFF	298000-29FFFF
SA84	0	1	0	1	0	1	0	0	64/32	540000-54FFFF	2A0000-2A7FFF
SA85	0	1	0	1	0	1	0	1	64/32	550000-55FFFF	2A8000-2AFFFF
SA86	0	1	0	1	0	1	1	0	64/32	560000-56FFFF	2B0000-2B7FFF
SA87	0	1	0	1	0	1	1	1	64/32	570000-57FFFF	2B8000-2BFFFF
SA88	0	1	0	1	1	0	0	0	64/32	580000-58FFFF	2C0000-2C7FFF
SA89	0	1	0	1	1	0	0	1	64/32	590000-59FFFF	2C8000-2CFFFF
SA90	0	1	0	1	1	0	1	0	64/32	5A0000-5AFFFF	2D0000-2D7FFF
SA91	0	1	0	1	1	0	1	1	64/32	5B0000-5BFFFF	2D8000-2DFFFF
SA92	0	1	0	1	1	1	0	0	64/32	5C0000-5CFFFF	2E0000-2E7FFF
SA93	0	1	0	1	1	1	0	1	64/32	5D0000-5DFFFF	2E8000-2EFFFF
SA94	0	1	0	1	1	1	1	0	64/32	5E0000-5EFFFF	2F0000-2F7FFF

Table 2. Sector Address Table (Continued)

Sector	A22-A15								Sector Size (Kbytes/Kwords)	8-bit Address Range (in hexadecimal)	16-bit Address Range (in hexadecimal)
	0	1	0	1	1	1	1	1			
SA95	0	1	0	1	1	1	1	1	64/32	5F0000-5FFFFF	2F8000-2FFFFF
SA96	0	1	1	0	0	0	0	0	64/32	600000-60FFFF	300000-307FFF
SA97	0	1	1	0	0	0	0	1	64/32	610000-61FFFF	308000-30FFFF
SA98	0	1	1	0	0	0	1	0	64/32	620000-62FFFF	310000-317FFF
SA99	0	1	1	0	0	0	1	1	64/32	630000-63FFFF	318000-31FFFF
SA100	0	1	1	0	0	1	0	0	64/32	640000-64FFFF	320000-327FFF
SA101	0	1	1	0	0	1	0	1	64/32	650000-65FFFF	328000-32FFFF
SA102	0	1	1	0	0	1	1	0	64/32	660000-66FFFF	330000-337FFF
SA103	0	1	1	0	0	1	1	1	64/32	670000-67FFFF	338000-33FFFF
SA104	0	1	1	0	1	0	0	0	64/32	680000-68FFFF	340000-347FFF
SA105	0	1	1	0	1	0	0	1	64/32	690000-69FFFF	348000-34FFFF
SA106	0	1	1	0	1	0	1	0	64/32	6A0000-6AFFFF	350000-357FFF
SA107	0	1	1	0	1	0	1	1	64/32	6B0000-6BFFFF	358000-35FFFF
SA108	0	1	1	0	1	1	0	0	64/32	6C0000-6CFFFF	360000-367FFF
SA109	0	1	1	0	1	1	0	1	64/32	6D0000-6DFFFF	368000-36FFFF
SA110	0	1	1	0	1	1	1	0	64/32	6E0000-6EFFFF	370000-377FFF
SA111	0	1	1	0	1	1	1	1	64/32	6F0000-6FFFFF	378000-37FFFF
SA112	0	1	1	1	0	0	0	0	64/32	700000-70FFFF	380000-387FFF
SA113	0	1	1	1	0	0	0	1	64/32	710000-71FFFF	388000-38FFFF
SA114	0	1	1	1	0	0	1	0	64/32	720000-72FFFF	390000-397FFF
SA115	0	1	1	1	0	0	1	1	64/32	730000-73FFFF	398000-39FFFF
SA116	0	1	1	1	0	1	0	0	64/32	740000-74FFFF	3A0000-3A7FFF
SA117	0	1	1	1	0	1	0	1	64/32	750000-75FFFF	3A8000-3AFFFF
SA118	0	1	1	1	0	1	1	0	64/32	760000-76FFFF	3B0000-3B7FFF
SA119	0	1	1	1	0	1	1	1	64/32	770000-77FFFF	3B8000-3BFFFF
SA120	0	1	1	1	1	0	0	0	64/32	780000-78FFFF	3C0000-3C7FFF
SA121	0	1	1	1	1	0	0	1	64/32	790000-79FFFF	3C8000-3CFFFF
SA122	0	1	1	1	1	0	1	0	64/32	7A0000-7AFFFF	3D0000-3D7FFF
SA123	0	1	1	1	1	0	1	1	64/32	7B0000-7BFFFF	3D8000-3DFFFF
SA124	0	1	1	1	1	1	0	0	64/32	7C0000-7CFFFF	3E0000-3E7FFF
SA125	0	1	1	1	1	1	0	1	64/32	7D0000-7DFFFF	3E8000-3EFFFF
SA126	0	1	1	1	1	1	1	0	64/32	7E0000-7EFFFF	3F0000-3F7FFF
SA127	0	1	1	1	1	1	1	1	64/32	7F0000-7FFFFF	3F8000-3FFFFF
SA128	1	0	0	0	0	0	0	0	64/32	800000-80FFFF	400000-407FFF
SA129	1	0	0	0	0	0	0	1	64/32	810000-81FFFF	408000-40FFFF
SA130	1	0	0	0	0	0	1	0	64/32	820000-82FFFF	410000-417FFF
SA131	1	0	0	0	0	0	1	1	64/32	830000-83FFFF	418000-41FFFF
SA132	1	0	0	0	0	1	0	0	64/32	840000-84FFFF	420000-427FFF
SA133	1	0	0	0	0	1	0	1	64/32	850000-85FFFF	428000-42FFFF
SA134	1	0	0	0	0	1	1	0	64/32	860000-86FFFF	430000-437FFF
SA135	1	0	0	0	0	1	1	1	64/32	870000-87FFFF	438000-43FFFF
SA136	1	0	0	0	1	0	0	0	64/32	880000-88FFFF	440000-447FFF
SA137	1	0	0	0	1	0	0	1	64/32	890000-89FFFF	448000-44FFFF
SA138	1	0	0	0	1	0	1	0	64/32	8A0000-8AFFFF	450000-457FFF
SA139	1	0	0	0	1	0	1	1	64/32	8B0000-8BFFFF	458000-45FFFF
SA140	1	0	0	0	1	1	0	0	64/32	8C0000-8CFFFF	460000-467FFF
SA141	1	0	0	0	1	1	0	1	64/32	8D0000-8DFFFF	468000-46FFFF
SA142	1	0	0	0	1	1	1	0	64/32	8E0000-8EFFFF	470000-477FFF

Table 2. Sector Address Table (Continued)

Sector	A22-A15								Sector Size (Kbytes/Kwords)	8-bit Address Range (in hexadecimal)	16-bit Address Range (in hexadecimal)
	1	0	0	0	1	1	1	1			
SA143	1	0	0	0	1	1	1	1	64/32	8F0000-8FFFFFFF	478000-47FFFF
SA144	1	0	0	1	0	0	0	0	64/32	900000-90FFFF	480000-487FFF
SA145	1	0	0	1	0	0	0	1	64/32	910000-91FFFF	488000-48FFFF
SA146	1	0	0	1	0	0	1	0	64/32	920000-92FFFF	490000-497FFF
SA147	1	0	0	1	0	0	1	1	64/32	930000-93FFFF	498000-49FFFF
SA148	1	0	0	1	0	1	0	0	64/32	940000-94FFFF	4A0000-4A7FFF
SA149	1	0	0	1	0	1	0	1	64/32	950000-95FFFF	4A8000-4AFFFF
SA150	1	0	0	1	0	1	1	0	64/32	960000-96FFFF	4B0000-4B7FFF
SA151	1	0	0	1	0	1	1	1	64/32	970000-97FFFF	4B8000-4BFFFF
SA152	1	0	0	1	1	0	0	0	64/32	980000-98FFFF	4C0000-4C7FFF
SA153	1	0	0	1	1	0	0	1	64/32	990000-99FFFF	4C8000-4CFFFF
SA154	1	0	0	1	1	0	1	0	64/32	9A0000-9AFFFF	4D0000-4D7FFF
SA155	1	0	0	1	1	0	1	1	64/32	9B0000-9BFFFF	4D8000-4DFFFF
SA156	1	0	0	1	1	1	0	0	64/32	9C0000-9CFFFF	4E0000-4E7FFF
SA157	1	0	0	1	1	1	0	1	64/32	9D0000-9DFFFF	4E8000-4EFFFF
SA158	1	0	0	1	1	1	1	0	64/32	9E0000-9EFFFF	4F0000-4F7FFF
SA159	1	0	0	1	1	1	1	1	64/32	9F0000-9FFFFFFF	4F8000-4FFFFFFF
SA160	1	0	1	0	0	0	0	0	64/32	A00000-A0FFFF	500000-507FFF
SA161	1	0	1	0	0	0	0	1	64/32	A10000-A1FFFF	508000-50FFFF
SA162	1	0	1	0	0	0	1	0	64/32	A20000-A2FFFF	510000-517FFF
SA163	1	0	1	0	0	0	1	1	64/32	A30000-A3FFFF	518000-51FFFF
SA164	1	0	1	0	0	1	0	0	64/32	A40000-A4FFFF	520000-527FFF
SA165	1	0	1	0	0	1	0	1	64/32	A50000-A5FFFF	528000-52FFFF
SA166	1	0	1	0	0	1	1	0	64/32	A60000-A6FFFF	530000-537FFF
SA167	1	0	1	0	0	1	1	1	64/32	A70000-A7FFFF	538000-53FFFF
SA168	1	0	1	0	1	0	0	0	64/32	A80000-A8FFFF	540000-547FFF
SA169	1	0	1	0	1	0	0	1	64/32	A90000-A9FFFF	548000-54FFFF
SA170	1	0	1	0	1	0	1	0	64/32	AA0000-AAFFFF	550000-557FFF
SA171	1	0	1	0	1	0	1	1	64/32	AB0000-ABFFFF	558000-55FFFF
SA172	1	0	1	0	1	1	0	0	64/32	AC0000-ACFFFF	560000-567FFF
SA173	1	0	1	0	1	1	0	1	64/32	AD0000-ADFFFF	568000-56FFFF
SA174	1	0	1	0	1	1	1	0	64/32	AE0000-AEFFFF	570000-577FFF
SA175	1	0	1	0	1	1	1	1	64/32	AF0000-AFFFFFFF	578000-57FFFF
SA176	1	0	1	1	0	0	0	0	64/32	B00000-B0FFFF	580000-587FFF
SA177	1	0	1	1	0	0	0	1	64/32	B10000-B1FFFF	588000-58FFFF
SA178	1	0	1	1	0	0	1	0	64/32	B20000-B2FFFF	590000-597FFF
SA179	1	0	1	1	0	0	1	1	64/32	B30000-B3FFFF	598000-59FFFF
SA180	1	0	1	1	0	1	0	0	64/32	B40000-B4FFFF	5A0000-5A7FFF
SA181	1	0	1	1	0	1	0	1	64/32	B50000-B5FFFF	5A8000-5AFFFF
SA182	1	0	1	1	0	1	1	0	64/32	B60000-B6FFFF	5B0000-5B7FFF
SA183	1	0	1	1	0	1	1	1	64/32	B70000-B7FFFF	5B8000-5BFFFF
SA184	1	0	1	1	1	0	0	0	64/32	B80000-B8FFFF	5C0000-5C7FFF
SA185	1	0	1	1	1	0	0	1	64/32	B90000-B9FFFF	5C8000-5CFFFF
SA186	1	0	1	1	1	0	1	0	64/32	BA0000-BAFFFF	5D0000-5D7FFF
SA187	1	0	1	1	1	0	1	1	64/32	BB0000-BBFFFF	5D8000-5DFFFF
SA188	1	0	1	1	1	1	0	0	64/32	BC0000-BCFFFF	5E0000-5E7FFF
SA189	1	0	1	1	1	1	0	1	64/32	BD0000-BDFFFF	5E8000-5EFFFF
SA190	1	0	1	1	1	1	1	0	64/32	BE0000-BEFFFF	5F0000-5F7FFF

Table 2. Sector Address Table (Continued)

Sector	A22–A15								Sector Size (Kbytes/Kwords)	8-bit Address Range (in hexadecimal)	16-bit Address Range (in hexadecimal)
	1	0	1	1	1	1	1	1			
SA191	1	0	1	1	1	1	1	1	64/32	BF0000–BFFFFFFF	5F8000–5FFFFFFF
SA192	1	1	0	0	0	0	0	0	64/32	C00000–C0FFFF	600000–607FFF
SA193	1	1	0	0	0	0	0	1	64/32	C10000–C1FFFF	608000–60FFFF
SA194	1	1	0	0	0	0	1	0	64/32	C20000–C2FFFF	610000–617FFF
SA195	1	1	0	0	0	0	1	1	64/32	C30000–C3FFFF	618000–61FFFF
SA196	1	1	0	0	0	1	0	0	64/32	C40000–C4FFFF	620000–627FFF
SA197	1	1	0	0	0	1	0	1	64/32	C50000–C5FFFF	628000–62FFFF
SA198	1	1	0	0	0	1	1	0	64/32	C60000–C6FFFF	630000–637FFF
SA199	1	1	0	0	0	1	1	1	64/32	C70000–C7FFFF	638000–63FFFF
SA200	1	1	0	0	1	0	0	0	64/32	C80000–C8FFFF	640000–647FFF
SA201	1	1	0	0	1	0	0	1	64/32	C90000–C9FFFF	648000–64FFFF
SA202	1	1	0	0	1	0	1	0	64/32	CA0000–CAFFFF	650000–657FFF
SA203	1	1	0	0	1	0	1	1	64/32	CB0000–CBFFFF	658000–65FFFF
SA204	1	1	0	0	1	1	0	0	64/32	CC0000–CCFFFF	660000–667FFF
SA205	1	1	0	0	1	1	0	1	64/32	CD0000–CDFFFF	668000–66FFFF
SA206	1	1	0	0	1	1	1	0	64/32	CE0000–CEFFFF	670000–677FFF
SA207	1	1	0	0	1	1	1	1	64/32	CF0000–CFFFFFFF	678000–67FFFF
SA208	1	1	0	1	0	0	0	0	64/32	D00000–D0FFFF	680000–687FFF
SA209	1	1	0	1	0	0	0	1	64/32	D10000–D1FFFF	688000–68FFFF
SA210	1	1	0	1	0	0	1	0	64/32	D20000–D2FFFF	690000–697FFF
SA211	1	1	0	1	0	0	1	1	64/32	D30000–D3FFFF	698000–69FFFF
SA212	1	1	0	1	0	1	0	0	64/32	D40000–D4FFFF	6A0000–6A7FFF
SA213	1	1	0	1	0	1	0	1	64/32	D50000–D5FFFF	6A8000–6AFFFF
SA214	1	1	0	1	0	1	1	0	64/32	D60000–D6FFFF	6B0000–6B7FFF
SA215	1	1	0	1	0	1	1	1	64/32	D70000–D7FFFF	6B8000–6BFFFF
SA216	1	1	0	1	1	0	0	0	64/32	D80000–D8FFFF	6C0000–6C7FFF
SA217	1	1	0	1	1	0	0	1	64/32	D90000–D9FFFF	6C8000–6CFFFF
SA218	1	1	0	1	1	0	1	0	64/32	DA0000–DAFFFF	6D0000–6D7FFF
SA219	1	1	0	1	1	0	1	1	64/32	DB0000–DBFFFF	6D8000–6DFFFF
SA220	1	1	0	1	1	1	0	0	64/32	DC0000–DCFFFF	6E0000–6E7FFF
SA221	1	1	0	1	1	1	0	1	64/32	DD0000–DDFFFF	6E8000–6EFFFF
SA222	1	1	0	1	1	1	1	0	64/32	DE0000–DEFFFF	6F0000–6F7FFF
SA223	1	1	0	1	1	1	1	1	64/32	DF0000–DFFFFFFF	6F8000–6FFFFFFF
SA224	1	1	1	0	0	0	0	0	64/32	E00000–E0FFFF	700000–707FFF
SA225	1	1	1	0	0	0	0	1	64/32	E10000–E1FFFF	708000–70FFFF
SA226	1	1	1	0	0	0	1	0	64/32	E20000–E2FFFF	710000–717FFF
SA227	1	1	1	0	0	0	1	1	64/32	E30000–E3FFFF	718000–71FFFF
SA228	1	1	1	0	0	1	0	0	64/32	E40000–E4FFFF	720000–727FFF
SA229	1	1	1	0	0	1	0	1	64/32	E50000–E5FFFF	728000–72FFFF
SA230	1	1	1	0	0	1	1	0	64/32	E60000–E6FFFF	730000–737FFF
SA231	1	1	1	0	0	1	1	1	64/32	E70000–E7FFFF	738000–73FFFF
SA232	1	1	1	0	1	0	0	0	64/32	E80000–E8FFFF	740000–747FFF
SA233	1	1	1	0	1	0	0	1	64/32	E90000–E9FFFF	748000–74FFFF
SA234	1	1	1	0	1	0	1	0	64/32	EA0000–EAFFFF	750000–757FFF
SA235	1	1	1	0	1	0	1	1	64/32	EB0000–EBFFFF	758000–75FFFF
SA236	1	1	1	0	1	1	0	0	64/32	EC0000–ECFFFF	760000–767FFF
SA237	1	1	1	0	1	1	0	1	64/32	ED0000–EDFFFF	768000–76FFFF
SA238	1	1	1	0	1	1	1	0	64/32	EE0000–EEFFFF	770000–777FFF

Table 2. Sector Address Table (Continued)

Sector	A22-A15								Sector Size (Kbytes/Kwords)	8-bit Address Range (in hexadecimal)	16-bit Address Range (in hexadecimal)
	1	1	1	0	1	1	1	1			
SA239	1	1	1	0	1	1	1	1	64/32	EF0000-EFFFFFFF	778000-77FFFF
SA240	1	1	1	1	0	0	0	0	64/32	F00000-F0FFFF	780000-787FFF
SA241	1	1	1	1	0	0	0	1	64/32	F10000-F1FFFF	788000-78FFFF
SA242	1	1	1	1	0	0	1	0	64/32	F20000-F2FFFF	790000-797FFF
SA243	1	1	1	1	0	0	1	1	64/32	F30000-F3FFFF	798000-79FFFF
SA244	1	1	1	1	0	1	0	0	64/32	F40000-F4FFFF	7A0000-7A7FFF
SA245	1	1	1	1	0	1	0	1	64/32	F50000-F5FFFF	7A8000-7AFFFF
SA246	1	1	1	1	0	1	1	0	64/32	F60000-F6FFFF	7B0000-7B7FFF
SA247	1	1	1	1	0	1	1	1	64/32	F70000-F7FFFF	7B8000-7BFFFF
SA248	1	1	1	1	1	0	0	0	64/32	F80000-F8FFFF	7C0000-7C7FFF
SA249	1	1	1	1	1	0	0	1	64/32	F90000-F9FFFF	7C8000-7CFFFF
SA250	1	1	1	1	1	0	1	0	64/32	FA0000-FAFFFF	7D0000-7D7FFF
SA251	1	1	1	1	1	0	1	1	64/32	FB0000-FBFFFF	7D8000-7DFFFF
SA252	1	1	1	1	1	1	0	0	64/32	FC0000-FCFFFF	7E0000-7E7FFF
SA253	1	1	1	1	1	1	0	1	64/32	FD0000-FDFFFF	7E8000-7EFFFF
SA254	1	1	1	1	1	1	1	0	64/32	FE0000-FEFFFF	7F0000-7F7FFF
SA255	1	1	1	1	1	1	1	1	64/32	FF0000-FFFFFF	7F8000-7FFFFF

Autoselect Mode

The autoselect mode provides manufacturer and device identification, and sector group protection verification, through identifier codes output on DQ7–DQ0. This mode is primarily intended for programming equipment to automatically match a device to be programmed with its corresponding programming algorithm. However, the autoselect codes can also be accessed in-system through the command register.

When using programming equipment, the autoselect mode requires VID on address pin A9. Address pins A6, A3, A2, A1, and A0 must be as shown in Table 3.

In addition, when verifying sector protection, the sector address must appear on the appropriate highest order address bits (see Table 2). Table 3 shows the remaining address bits that are don't care. When all necessary bits have been set as required, the programming equipment may then read the corresponding identifier code on DQ7–DQ0.

To access the autoselect codes in-system, the host system can issue the autoselect command via the command register, as shown in Tables 10 and 11. This method does not require V_{ID}. Refer to the Autoselect Command Sequence section for more information.

Table 3. Autoselect Codes, (High Voltage Method)

Description	CE#	OE#	WE#	A22 to A15	A14 to A10	A9	A8 to A7	A6	A5 to A4	A3 to A2	A1	A0	DQ8 to DQ15		DQ7 to DQ0								
													BYTE# = V _{IH}	BYTE# = V _{IL}									
Manufacturer ID: AMD	L	L	H	X	X	V _{ID}	X	L	X	L	L	L	00	X	01h								
Device ID	Cycle 1		L	L	H	X	X	V _{ID}	X	L	X	L	L	H	22	X	7Eh						
	Cycle 2																	H	H	L	22	X	12h
	Cycle 3																						
Sector Group Protection Verification	L	L	H	SA	X	V _{ID}	X	L	X	L	H	L	X	X	01h (protected), 00h (unprotected)								
SecSi Sector Indicator Bit (DQ7), WP# protects highest address sector	L	L	H	X	X	V _{ID}	X	L	X	L	H	H	X	X	98h (factory locked), 18h (not factory locked)								
SecSi Sector Indicator Bit (DQ7), WP# protects lowest address sector	L	L	H	X	X	V _{ID}	X	L	X	L	H	H	X	X	88h (factory locked), 08h (not factory locked)								

Legend: L = Logic Low = V_{IL}, H = Logic High = V_{IH}, SA = Sector Address, X = Don't care.

Sector Group Protection and Unprotection

The hardware sector group protection feature disables both program and erase operations in any sector group. The hardware sector group unprotection feature re-enables both program and erase operations in previously protected sector groups. Sector group protection/unprotection can be implemented via two methods.

Sector group protection/unprotection requires V_{ID} on the RESET# pin only, and can be implemented either in-system or via programming equipment. Figure 2 shows the algorithms and Figure 25 shows the timing diagram. This method uses standard microprocessor bus cycle timing. For sector group unprotect, all unprotected sector group must first be protected prior to the first sector group unprotect write cycle.

The device is shipped with all sector groups unprotected. AMD offers the option of programming and protecting sector groups at its factory prior to shipping the device through AMD's ExpressFlash™ Service. Contact an AMD representative for details.

It is possible to determine whether a sector group is protected or unprotected. See the Autoselect Mode section for details.

Table 4. Sector Group Protection/Unprotection Address Table

Sector Group	A22–A15
SA0	00000000
SA1	00000001
SA2	00000010
SA3	00000011
SA4–SA7	000001xx
SA8–SA11	000010xx
SA12–SA15	000011xx
SA16–SA19	000100xx
SA20–SA23	000101xx
SA24–SA27	000110xx
SA28–SA31	000111xx
SA32–SA35	001000xx
SA36–SA39	001001xx
SA40–SA43	001010xx
SA44–SA47	001011xx
SA48–SA51	001100xx
SA52–SA55	001101xx
SA56–SA59	001110xx
SA60–SA63	001111xx
SA64–SA67	010000xx
SA68–SA71	010001xx
SA72–SA75	010010xx
SA76–SA79	010011xx
SA80–SA83	010100xx

Sector Group	A22–A15
SA84–SA87	010101xx
SA88–SA91	010110xx
SA92–SA95	010111xx
SA96–SA99	011000xx
SA100–SA103	011001xx
SA104–SA107	011010xx
SA108–SA111	011011xx
SA112–SA115	011100xx
SA116–SA119	011101xx
SA120–SA123	011110xx
SA124–SA127	011111xx
SA128–SA131	100000xx
SA132–SA135	100001xx
SA136–SA139	100010xx
SA140–SA143	100011xx
SA144–SA147	100100xx
SA148–SA151	100101xx
SA152–SA155	100110xx
SA156–SA159	100111xx
SA160–SA163	101000xx
SA164–SA167	101001xx
SA168–SA171	101010xx
SA172–SA175	101011xx
SA176–SA179	101100xx
SA180–SA183	101101xx
SA184–SA187	101110xx
SA188–SA191	101111xx
SA192–SA195	110000xx
SA196–SA199	110001xx
SA200–SA203	110010xx
SA204–SA207	110011xx
SA208–SA211	110100xx
SA212–SA215	110101xx
SA216–SA219	110110xx
SA220–SA223	110111xx
SA224–SA227	111000xx
SA228–SA231	111001xx
SA232–SA235	111010xx
SA236–SA239	111011xx
SA240–SA243	111100xx
SA244–SA247	111101xx
SA248–SA251	111110xx
SA252	11111100
SA253	11111101
SA254	11111110
SA255	11111111

Write Protect (WP#)

The Write Protect function provides a hardware method of protecting the first or last sector group without using V_{ID} . Write Protect is one of two functions provided by the WP#/ACC input.

If the system asserts V_{IL} on the WP#/ACC pin, the device disables program and erase functions in the first or last sector group independently of whether those sector groups were protected or unprotected using the method described in "Sector Group Protection and Unprotection". Note that if WP#/ACC is at V_{IL} when the device is in the standby mode, the maximum input load current is increased. See the table in "DC Characteristics".

If the system asserts V_{IH} on the WP#/ACC pin, the device reverts to whether the first or last sector was previously set to be protected or unprotected using the method described in "Sector Group Protection and Unprotection". Note that WP# has an internal pullup; when unconnected, WP# is at V_{IH} .

Temporary Sector Group Unprotect

This feature allows temporary unprotection of previously protected sector groups to change data in-system. The Sector Group Unprotect mode is activated by setting the RESET# pin to V_{ID} . During this mode, formerly protected sector groups can be programmed or erased by selecting the sector group addresses. Once V_{ID} is removed from the RESET# pin, all the previously protected sector groups are protected again.

Figure 1 shows the algorithm, and Figure 24 shows the timing diagrams, for this feature.

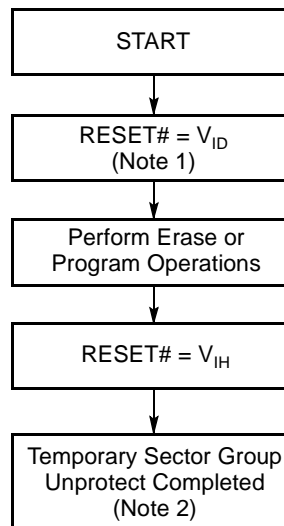

Notes:

1. All protected sector groups unprotected (If WP# = V_{IL} , the first or last sector will remain protected).
2. All previously protected sector groups are protected once again.

Figure 1. Temporary Sector Group Unprotect Operation

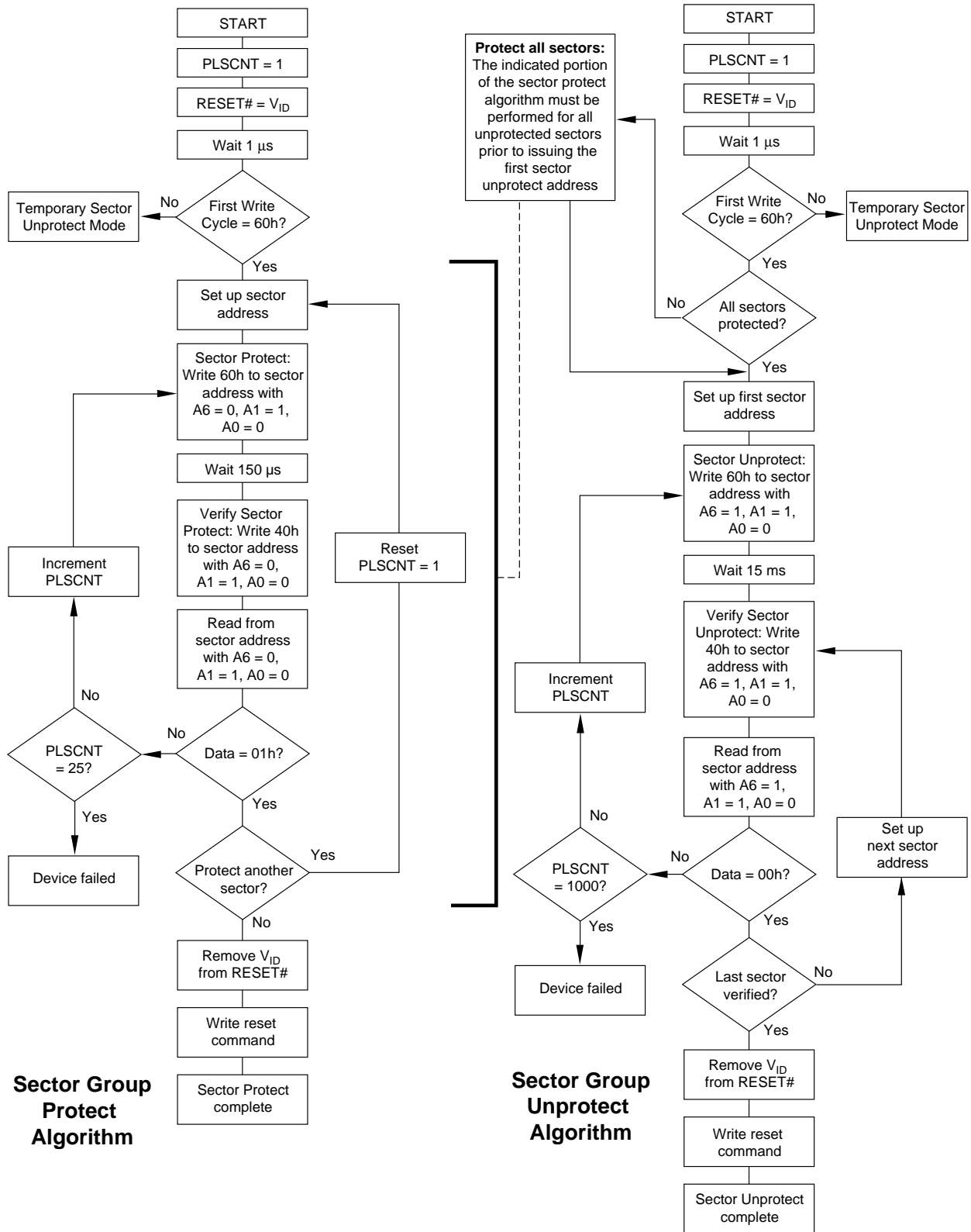

Figure 2. In-System Sector Group Protect/Unprotect Algorithms

SecSi (Secured Silicon) Sector Flash Memory Region

The SecSi (Secured Silicon) Sector feature provides a Flash memory region that enables permanent part identification through an Electronic Serial Number (ESN). The SecSi Sector is 128 words/256 bytes in length, and uses a SecSi Sector Indicator Bit (DQ7) to indicate whether or not the SecSi Sector is locked when shipped from the factory. This bit is permanently set at the factory and cannot be changed, which prevents cloning of a factory locked part. This ensures the security of the ESN once the product is shipped to the field.

AMD offers the device with the SecSi Sector either factory locked or customer lockable. The factory-locked version is always protected when shipped from the factory, and has the SecSi (Secured Silicon) Sector Indicator Bit permanently set to a “1.” The customer-lockable version is shipped with the SecSi Sector unprotected, allowing customers to program the sector after receiving the device. The customer-lockable version also has the SecSi Sector Indicator Bit permanently set to a “0.” Thus, the SecSi Sector Indicator Bit prevents customer-lockable devices from being used to replace devices that are factory locked.

The SecSi sector address space in this device is allocated as follows:

Table 5. SecSi Sector Contents

SecSi Sector Address Range		Standard Factory Locked	ExpressFlash Factory Locked	Customer Lockable
x16	x8			
000000h–000007h	000000h–00000Fh	ESN	ESN or determined by customer	Determined by customer
000008h–00007Fh	000010h–0000FFh	Unavailable	Determined by customer	

The system accesses the SecSi Sector through a command sequence (see “Enter SecSi Sector/Exit SecSi Sector Command Sequence”). After the system has written the Enter SecSi Sector command sequence, it may read the SecSi Sector by using the addresses normally occupied by the first sector (SA0). This mode of operation continues until the system issues the Exit SecSi Sector command sequence, or until power is removed from the device. On power-up, or following a hardware reset, the device reverts to sending commands to sector SA0. *Note that the ACC function and unlock bypass modes are not available when the SecSi Sector is enabled.*

Factory Locked: SecSi Sector Programmed and Protected At the Factory

In devices with an ESN, the SecSi Sector is protected when the device is shipped from the factory. The SecSi Sector cannot be modified in any way. A factory locked device has an 8-word/16-byte random ESN at addresses 000000h–000007h.

Customers may opt to have their code programmed by AMD through the AMD ExpressFlash service. The devices are then shipped from AMD’s factory with the SecSi Sector permanently locked. Contact an AMD representative for details on using AMD’s ExpressFlash service.

Customer Lockable: SecSi Sector NOT Programmed or Protected At the Factory

As an alternative to the factory-locked version, the device may be ordered such that the customer may program and protect the 128-word/256 bytes SecSi sector.

The system may program the SecSi Sector using the write-buffer, accelerated and/or unlock bypass methods, in addition to the standard programming command sequence. See Command Definitions.

Programming and protecting the SecSi Sector must be used with caution since, once protected, there is no procedure available for unprotecting the SecSi Sector area and none of the bits in the SecSi Sector memory space can be modified in any way.

The SecSi Sector area can be protected using one of the following procedures:

- Write the three-cycle Enter SecSi Sector Region command sequence, and then follow the in-system sector protect algorithm as shown in Figure 2, except that *RESET# may be at either V_{IH} or V_{ID}* . This allows in-system protection of the SecSi Sector without raising any device pin to a high voltage. Note that this method is only applicable to the SecSi Sector.
- To verify the protect/unprotect status of the SecSi Sector, follow the algorithm shown in Figure 3.

Once the SecSi Sector is programmed, locked and verified, the system must write the Exit SecSi Sector Region command sequence to return to reading and writing within the remainder of the array.

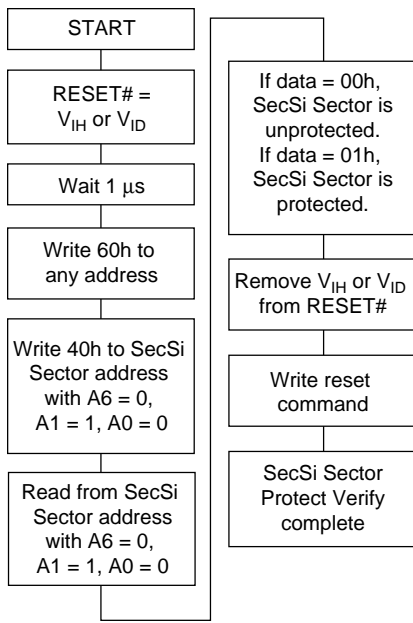

Figure 3. SecSi Sector Protect Verify

Hardware Data Protection

The command sequence requirement of unlock cycles for programming or erasing provides data protection against inadvertent writes (refer to Tables 10 and 11 for command definitions). In addition, the following hardware data protection measures prevent accidental erasure or programming, which might otherwise be

caused by spurious system level signals during V_{CC} power-up and power-down transitions, or from system noise.

Low V_{CC} Write Inhibit

When V_{CC} is less than V_{LKO} , the device does not accept any write cycles. This protects data during V_{CC} power-up and power-down. The command register and all internal program/erase circuits are disabled, and the device resets to the read mode. Subsequent writes are ignored until V_{CC} is greater than V_{LKO} . The system must provide the proper signals to the control pins to prevent unintentional writes when V_{CC} is greater than V_{LKO} .

Write Pulse “Glitch” Protection

Noise pulses of less than 5 ns (typical) on $OE\#$, $CE\#$ or $WE\#$ do not initiate a write cycle.

Logical Inhibit

Write cycles are inhibited by holding any one of $OE\# = V_{IL}$, $CE\# = V_{IH}$ or $WE\# = V_{IH}$. To initiate a write cycle, $CE\#$ and $WE\#$ must be a logical zero while $OE\#$ is a logical one.

Power-Up Write Inhibit

If $WE\# = CE\# = V_{IL}$ and $OE\# = V_{IH}$ during power up, the device does not accept commands on the rising edge of $WE\#$. The internal state machine is automatically reset to the read mode on power-up.

COMMON FLASH MEMORY INTERFACE (CFI)

The Common Flash Interface (CFI) specification outlines device and host system software interrogation handshake, which allows specific vendor-specified software algorithms to be used for entire families of devices. Software support can then be device-independent, JEDEC ID-independent, and forward- and backward-compatible for the specified flash device families. Flash vendors can standardize their existing interfaces for long-term compatibility.

This device enters the CFI Query mode when the system writes the CFI Query command, 98h, to address 55h, any time the device is ready to read array data. The system can read CFI information at the addresses given in Tables 6–9. To terminate reading CFI data, the system must write the reset command.

The system can also write the CFI query command when the device is in the autoselect mode. The device enters the CFI query mode, and the system can read CFI data at the addresses given in Tables 6–9. The system must write the reset command to return the device to reading array data.

For further information, please refer to the CFI Specification and CFI Publication 100, available via the World Wide Web at <http://www.amd.com/flash/cfi>. Alternatively, contact an AMD representative for copies of these documents.

Table 6. CFI Query Identification String

Addresses (x16)	Data	Description
10h 11h 12h	0051h 0052h 0059h	Query Unique ASCII string "QRY"
13h 14h	0002h 0000h	Primary OEM Command Set
15h 16h	0040h 0000h	Address for Primary Extended Table
17h 18h	0000h 0000h	Alternate OEM Command Set (00h = none exists)
19h 1Ah	0000h 0000h	Address for Alternate OEM Extended Table (00h = none exists)

Table 7. System Interface String

Addresses (x16)	Data	Description
1Bh	0027h	V_{CC} Min. (write/erase) D7–D4: volt, D3–D0: 100 millivolt
1Ch	0036h	V_{CC} Max. (write/erase) D7–D4: volt, D3–D0: 100 millivolt
1Dh	0000h	V_{PP} Min. voltage (00h = no V_{PP} pin present)
1Eh	0000h	V_{PP} Max. voltage (00h = no V_{PP} pin present)
1Fh	0007h	Typical timeout per single byte/word write 2^N μ s
20h	0007h	Typical timeout for Min. size buffer write 2^N μ s (00h = not supported)
21h	000Ah	Typical timeout per individual block erase 2^N ms
22h	0000h	Typical timeout for full chip erase 2^N ms (00h = not supported)
23h	0001h	Max. timeout for byte/word write 2^N times typical
24h	0005h	Max. timeout for buffer write 2^N times typical
25h	0004h	Max. timeout per individual block erase 2^N times typical
26h	0000h	Max. timeout for full chip erase 2^N times typical (00h = not supported)

Table 8. Device Geometry Definition

Addresses (x16)	Data	Description
27h	0018h	Device Size = 2 ^N byte
28h 29h	0002h 0000h	Flash Device Interface description (refer to CFI publication 100)
2Ah 2Bh	0005h 0000h	Max. number of byte in multi-byte write = 2 ^N (00h = not supported)
2Ch	0001h	Number of Erase Block Regions within device (01h = uniform device, 02h = boot device)
2Dh 2Eh 2Fh 30h	00FFh 0000h 0000h 0001h	Erase Block Region 1 Information (refer to the CFI specification or CFI publication 100)
31h 32h 33h 34h	0000h 0000h 0000h 0000h	Erase Block Region 2 Information (refer to CFI publication 100)
35h 36h 37h 38h	0000h 0000h 0000h 0000h	Erase Block Region 3 Information (refer to CFI publication 100)
39h 3Ah 3Bh 3Ch	0000h 0000h 0000h 0000h	Erase Block Region 4 Information (refer to CFI publication 100)

Table 9. Primary Vendor-Specific Extended Query

Addresses (x16)	Data	Description
40h 41h 42h	0050h 0052h 0049h	Query-unique ASCII string "PRI"
43h	0031h	Major version number, ASCII
44h	0033h	Minor version number, ASCII
45h	0008h	Address Sensitive Unlock (Bits 1-0) 0 = Required, 1 = Not Required Process Technology (Bits 7-2) 0010b = 0.23 μ m MirrorBit
46h	0002h	Erase Suspend 0 = Not Supported, 1 = To Read Only, 2 = To Read & Write
47h	0001h	Sector Protect 0 = Not Supported, X = Number of sectors in per group
48h	0001h	Sector Temporary Unprotect 00 = Not Supported, 01 = Supported
49h	0004h	Sector Protect/Unprotect scheme 04 = 29LV800 mode
4Ah	0000h	Simultaneous Operation 00 = Not Supported, X = Number of Sectors in Bank
4Bh	0000h	Burst Mode Type 00 = Not Supported, 01 = Supported
4Ch	0001h	Page Mode Type 00 = Not Supported, 01 = 4 Word Page, 02 = 8 Word Page
4Dh	00B5h	ACC (Acceleration) Supply Minimum 00h = Not Supported, D7-D4: Volt, D3-D0: 100 mV
4Eh	00C5h	ACC (Acceleration) Supply Maximum 00h = Not Supported, D7-D4: Volt, D3-D0: 100 mV
4Fh	0004h/ 0005h	Top/Bottom Boot Sector Flag 00h = Uniform Device without WP# protect, 02h = Bottom Boot Device, 03h = Top Boot Device, 04h = Uniform sectors bottom WP# protect, 05h = Uniform sectors top WP# protect
50h	0001h	Program Suspend 00h = Not Supported, 01h = Supported

COMMAND DEFINITIONS

Writing specific address and data commands or sequences into the command register initiates device operations. Tables 10 and 11 defines the valid register command sequences. *Writing incorrect address and data values or writing them in the improper sequence may place the device in an unknown state.* A reset command is then required to return the device to reading array data.

All addresses are latched on the falling edge of WE# or CE#, whichever happens later. All data is latched on the rising edge of WE# or CE#, whichever happens first. Refer to the AC Characteristics section for timing diagrams.

Reading Array Data

The device is automatically set to reading array data after device power-up. No commands are required to retrieve data. The device is ready to read array data after completing an Embedded Program or Embedded Erase algorithm.

After the device accepts an Erase Suspend command, the device enters the erase-suspend-read mode, after which the system can read data from any non-erase-suspended sector. After completing a programming operation in the Erase Suspend mode, the system may once again read array data with the same exception. See the Erase Suspend/Erase Resume Commands section for more information.

The system *must* issue the reset command to return the device to the read (or erase-suspend-read) mode if DQ5 goes high during an active program or erase operation, or if the device is in the autoselect mode. See the next section, Reset Command, for more information.

See also Requirements for Reading Array Data in the Device Bus Operations section for more information. The Read-Only Operations table provides the read parameters, and Figure 14 shows the timing diagram.

Reset Command

Writing the reset command resets the device to the read or erase-suspend-read mode. Address bits are don't cares for this command.

The reset command may be written between the sequence cycles in an erase command sequence before erasing begins. This resets the device to the read mode. Once erasure begins, however, the device ignores reset commands until the operation is complete.

The reset command may be written between the sequence cycles in a program command sequence before programming begins. This resets the device to

the read mode. If the program command sequence is written while the device is in the Erase Suspend mode, writing the reset command returns the device to the erase-suspend-read mode. Once programming begins, however, the device ignores reset commands until the operation is complete.

The reset command may be written between the sequence cycles in an autoselect command sequence. Once in the autoselect mode, the reset command must be written to return to the read mode. If the device entered the autoselect mode while in the Erase Suspend mode, writing the reset command returns the device to the erase-suspend-read mode.

If DQ5 goes high during a program or erase operation, writing the reset command returns the device to the read mode (or erase-suspend-read mode if the device was in Erase Suspend).

Note that if DQ1 goes high during a Write Buffer Programming operation, the system must write the Write-to-Buffer-Abort Reset command sequence to reset the device for the next operation.

Autoselect Command Sequence

The autoselect command sequence allows the host system to access the manufacturer and device codes, and determine whether or not a sector is protected. Tables 10 and 11 show the address and data requirements. This method is an alternative to that shown in Table 3, which is intended for PROM programmers and requires V_{ID} on address pin A9. The autoselect command sequence may be written to an address that is either in the read or erase-suspend-read mode. The autoselect command may not be written while the device is actively programming or erasing.

The autoselect command sequence is initiated by first writing two unlock cycles. This is followed by a third write cycle that contains the autoselect command. The device then enters the autoselect mode. The system may read at any address any number of times without initiating another autoselect command sequence:

- A read cycle at address XX00h returns the manufacturer code.
- Three read cycles at addresses 01h, 0Eh, and 0Fh return the device code.
- A read cycle to an address containing a sector address (SA), and the address 02h on A7–A0 in word mode returns 01h if the sector is protected, or 00h if it is unprotected.

The system must write the reset command to return to the read mode (or erase-suspend-read mode if the device was previously in Erase Suspend).

Enter SecSi Sector/Exit SecSi Sector Command Sequence

The SecSi Sector region provides a secured data area containing an 8-word/16-byte random Electronic Serial Number (ESN). The system can access the SecSi Sector region by issuing the three-cycle Enter SecSi Sector command sequence. The device continues to access the SecSi Sector region until the system issues the four-cycle Exit SecSi Sector command sequence. The Exit SecSi Sector command sequence returns the device to normal operation. Tables 10 and 11 show the address and data requirements for both command sequences. See also “SecSi (Secured Silicon) Sector Flash Memory Region” for further information. *Note that the ACC function and unlock bypass modes are not available when the SecSi Sector is enabled.*

Word/Byte Program Command Sequence

Programming is a four-bus-cycle operation. The program command sequence is initiated by writing two unlock write cycles, followed by the program set-up command. The program address and data are written next, which in turn initiate the Embedded Program algorithm. The system is *not* required to provide further controls or timings. The device automatically provides internally generated program pulses and verifies the programmed cell margin. Tables 10 and 11 show the address and data requirements for the word program command sequence.

When the Embedded Program algorithm is complete, the device then returns to the read mode and addresses are no longer latched. The system can determine the status of the program operation by using DQ7 or DQ6. Refer to the Write Operation Status section for information on these status bits.

Any commands written to the device during the Embedded Program Algorithm are ignored. Note that a **hardware reset** immediately terminates the program operation. The program command sequence should be reinitiated once the device has returned to the read mode, to ensure data integrity. *Note that the SecSi Sector, autoselect, and CFI functions are unavailable when a program operation is in progress.*

Programming is allowed in any sequence and across sector boundaries. **A bit cannot be programmed from “0” back to a “1.”** Attempting to do so may cause the device to set DQ5 = 1, or cause the DQ7 and DQ6 status bits to indicate the operation was successful. However, a succeeding read will show that the data is still “0.” Only erase operations can convert a “0” to a “1.”

Unlock Bypass Command Sequence

The unlock bypass feature allows the system to program words to the device faster than using the standard program command sequence. The unlock bypass command sequence is initiated by first writing two unlock cycles. This is followed by a third write cycle containing the unlock bypass command, 20h. The device then enters the unlock bypass mode. A two-cycle unlock bypass program command sequence is all that is required to program in this mode. The first cycle in this sequence contains the unlock bypass program command, A0h; the second cycle contains the program address and data. Additional data is programmed in the same manner. This mode dispenses with the initial two unlock cycles required in the standard program command sequence, resulting in faster total programming time. Tables 10 and 11 show the requirements for the command sequence.

During the unlock bypass mode, only the Unlock Bypass Program and Unlock Bypass Reset commands are valid. To exit the unlock bypass mode, the system must issue the two-cycle unlock bypass reset command sequence. The first cycle must contain the data 90h. The second cycle must contain the data 00h. The device then returns to the read mode.

Write Buffer Programming

Write Buffer Programming allows the system write to a maximum of 16 words/32 bytes in one programming operation. This results in faster effective programming time than the standard programming algorithms. The Write Buffer Programming command sequence is initiated by first writing two unlock cycles. This is followed by a third write cycle containing the Write Buffer Load command written at the Sector Address in which programming will occur. The fourth cycle writes the sector address and the number of word locations, minus one, to be programmed. For example, if the system will program 6 unique address locations, then 05h should be written to the device. This tells the device how many write buffer addresses will be loaded with data and therefore when to expect the Program Buffer to Flash command. The number of locations to program cannot exceed the size of the write buffer or the operation will abort.

The fifth cycle writes the first address location and data to be programmed. The write-buffer-page is selected by address bits $A_{MAX}-A_4$. All subsequent address/data pairs must fall within the selected-write-buffer-page. The system then writes the remaining address/data pairs into the write buffer. Write buffer locations may be loaded in any order.

The write-buffer-page address must be the same for all address/data pairs loaded into the write buffer. (This means Write Buffer Programming cannot be performed across multiple write-buffer pages. This also

means that Write Buffer Programming cannot be performed across multiple sectors. If the system attempts to load programming data outside of the selected write-buffer page, the operation will abort.

Note that if a Write Buffer address location is loaded multiple times, the address/data pair counter will be decremented for every data load operation. The host system must therefore account for loading a write-buffer location more than once. The counter decrements for each data load operation, not for each unique write-buffer-address location. Note also that if an address location is loaded more than once into the buffer, the final data loaded for that address will be programmed.

Once the specified number of write buffer locations have been loaded, the system must then write the Program Buffer to Flash command at the sector address. Any other address and data combination aborts the Write Buffer Programming operation. The device then begins programming. Data polling should be used while monitoring the last address location loaded into the write buffer. DQ7, DQ6, DQ5, and DQ1 should be monitored to determine the device status during Write Buffer Programming.

The write-buffer programming operation can be suspended using the standard program suspend/resume commands. Upon successful completion of the Write Buffer Programming operation, the device is ready to execute the next command.

The Write Buffer Programming Sequence can be aborted in the following ways:

- Load a value that is greater than the page buffer size during the Number of Locations to Program step.
- Write to an address in a sector different than the one specified during the Write-Buffer-Load command.

- Write an Address/Data pair to a different write-buffer-page than the one selected by the Starting Address during the write buffer data loading stage of the operation.

- Write data other than the Confirm Command after the specified number of data load cycles.

The abort condition is indicated by DQ1 = 1, DQ7 = DATA# (for the last address location loaded), DQ6 = toggle, and DQ5=0. A Write-to-Buffer-Abort Reset command sequence must be written to reset the device for the next operation. Note that the full 3-cycle Write-to-Buffer-Abort Reset command sequence is required when using Write-Buffer-Programming features in Unlock Bypass mode.

Programming is allowed in any sequence and across sector boundaries. **A bit cannot be programmed from “0” back to a “1.”** Attempting to do so may cause the device to set DQ5 = 1, or cause the DQ7 and DQ6 status bits to indicate the operation was successful. However, a succeeding read will show that the data is still “0.” Only erase operations can convert a “0” to a “1.”

Accelerated Program

The device offers accelerated program operations through the WP#/ACC pin. When the system asserts V_{HH} on the WP#/ACC pin, the device automatically enters the Unlock Bypass mode. The system may then write the two-cycle Unlock Bypass program command sequence. The device uses the higher voltage on the WP#/ACC pin to accelerate the operation. *Note that the WP#/ACC pin must not be at V_{HH} for operations other than accelerated programming, or device damage may result. WP# has an internal pullup; when unconnected, WP# is at V_{IH} .*

Figure 5 illustrates the algorithm for the program operation. Refer to the Erase and Program Operations table in the AC Characteristics section for parameters, and Figure 18 for timing diagrams.

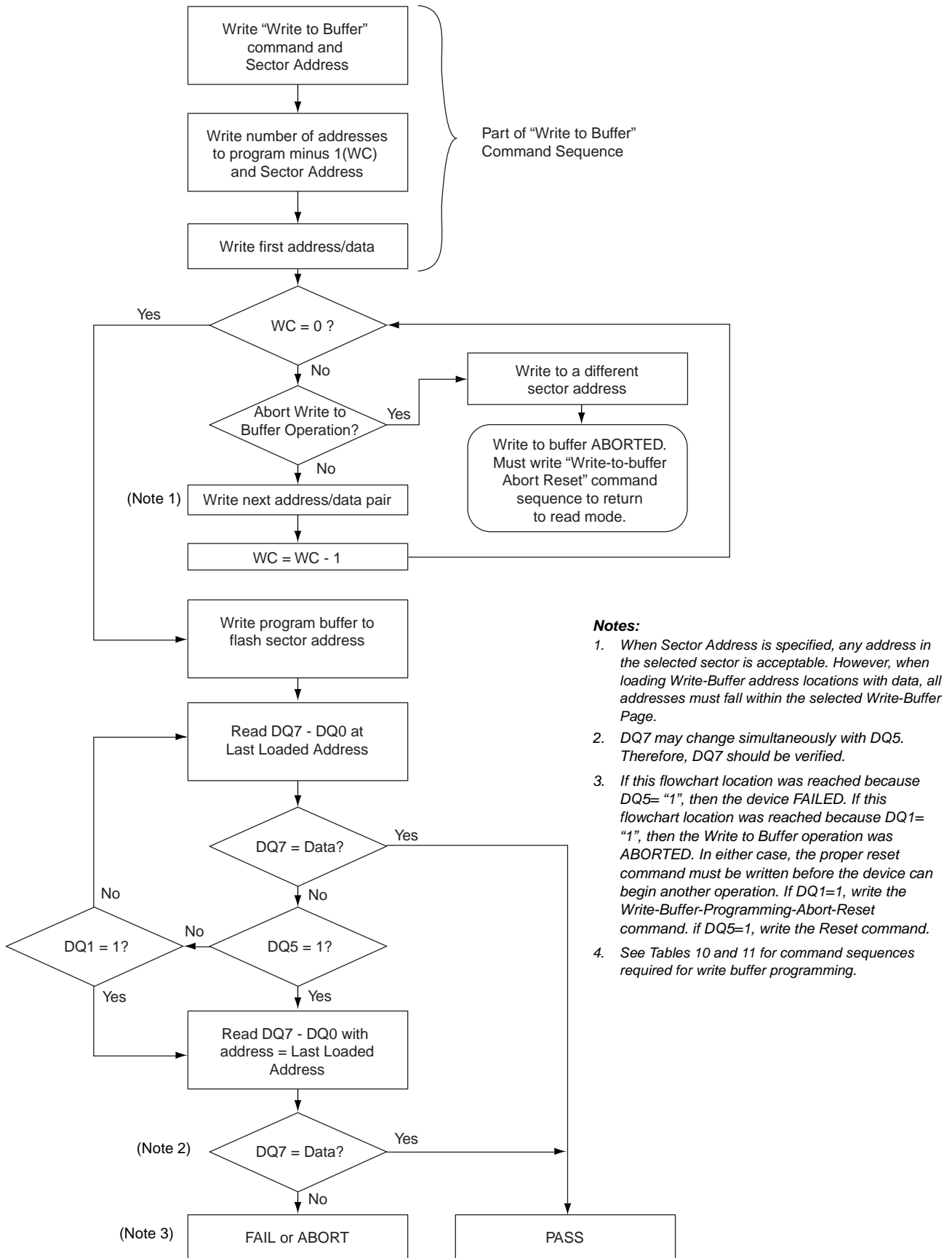
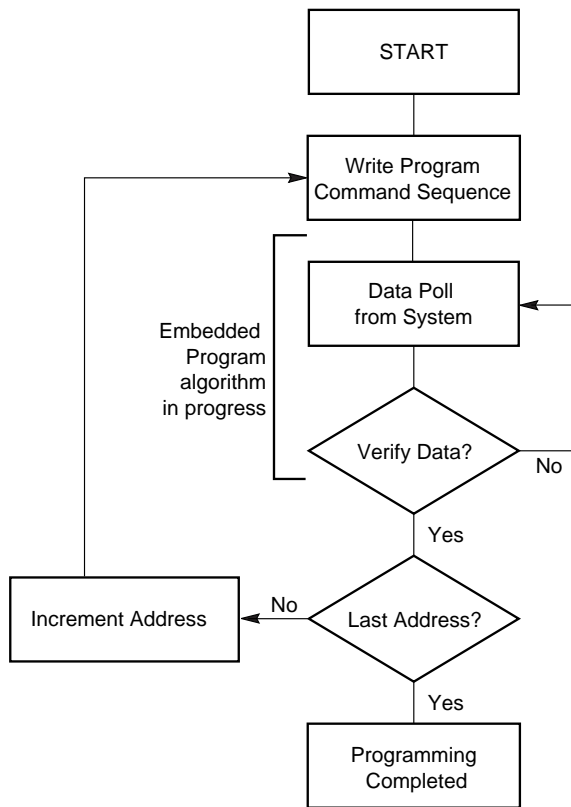

Figure 4. Write Buffer Programming Operation



Note: See Tables 10 and 11 for program command sequence.

Figure 5. Program Operation

Program Suspend/Program Resume Command Sequence

The Program Suspend command allows the system to interrupt a programming operation or a Write to Buffer programming operation so that data can be read from any non-suspended sector. When the Program Suspend command is written during a programming process, the device halts the program operation within 15 μ s maximum (5 μ s typical) and updates the status bits. Addresses are not required when writing the Program Suspend command.

After the programming operation has been suspended, the system can read array data from any non-suspended sector. The Program Suspend command may also be issued during a programming operation while an erase is suspended. In this case, data may be read from any addresses not in Erase Suspend or Program Suspend. If a read is needed from the SecSi Sector area (One-time Program area), then user must use the proper command sequences to enter and exit this region.

The system may also write the autoselect command sequence when the device is in the Program Suspend mode. The system can read as many autoselect codes as required. When the device exits the autoselect mode, the device reverts to the Program Suspend mode, and is ready for another valid operation. See Autoselect Command Sequence for more information.

After the Program Resume command is written, the device reverts to programming. The system can determine the status of the program operation using the DQ7 or DQ6 status bits, just as in the standard program operation. See Write Operation Status for more information.

The system must write the Program Resume command (address bits are don't care) to exit the Program Suspend mode and continue the programming operation. Further writes of the Resume command are ignored. Another Program Suspend command can be written after the device has resume programming.

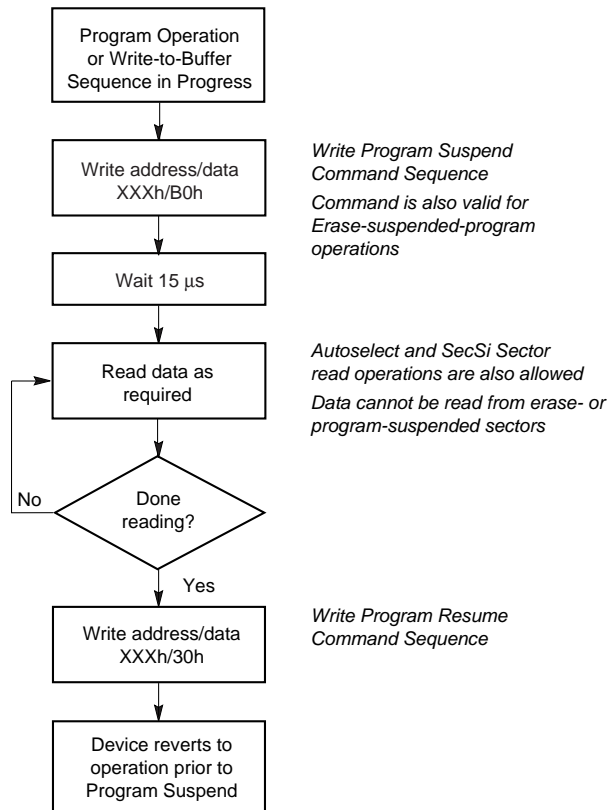

Figure 6. Program Suspend/Program Resume

Chip Erase Command Sequence

Chip erase is a six bus cycle operation. The chip erase command sequence is initiated by writing two unlock cycles, followed by a set-up command. Two additional unlock write cycles are then followed by the chip erase command, which in turn invokes the Embedded Erase algorithm. The device does *not* require the system to preprogram prior to erase. The Embedded Erase algorithm automatically preprograms and verifies the entire memory for an all zero data pattern prior to electrical erase. The system is not required to provide any controls or timings during these operations. Tables 10 and 11 show the address and data requirements for the chip erase command sequence.

When the Embedded Erase algorithm is complete, the device returns to the read mode and addresses are no longer latched. The system can determine the status of the erase operation by using DQ7, DQ6, or DQ2. Refer to the Write Operation Status section for information on these status bits.

Any commands written during the chip erase operation are ignored. However, note that a **hardware reset** immediately terminates the erase operation. If that occurs, the chip erase command sequence should be reinitiated once the device has returned to reading array data, to ensure data integrity. *Note that the SecSi Sector, autoselect, and CFI functions are unavailable when an program operation is in progress.*

Figure 6 illustrates the algorithm for the erase operation. Refer to the Erase and Program Operations tables in the AC Characteristics section for parameters, and Figure 20 section for timing diagrams.

Sector Erase Command Sequence

Sector erase is a six bus cycle operation. The sector erase command sequence is initiated by writing two unlock cycles, followed by a set-up command. Two additional unlock cycles are written, and are then followed by the address of the sector to be erased, and the sector erase command. Tables 9 & 10 shows the address and data requirements for the sector erase command sequence.

The device does *not* require the system to preprogram prior to erase. The Embedded Erase algorithm automatically programs and verifies the entire memory for an all zero data pattern prior to electrical erase. The system is not required to provide any controls or timings during these operations.

After the command sequence is written, a sector erase time-out of 50 μ s occurs. During the time-out period, additional sector addresses and sector erase commands may be written. Loading the sector erase buffer may be done in any sequence, and the number of sectors may be from one sector to all sectors. The time between these additional cycles must be less than 50 μ s, otherwise erasure may begin. Any sector erase address and command following the exceeded time-out may or may not be accepted. It is recommended that processor interrupts be disabled during this time to ensure all commands are accepted. The interrupts can be re-enabled after the last Sector Erase command is written. **Any command other than Sector Erase or Erase Suspend during the time-out period resets the device to the read mode.** The system must rewrite the command sequence and any additional addresses and commands. *Note that the SecSi Sector, autoselect, and CFI functions are unavailable when an erase operation is in progress.*

The system can monitor DQ3 to determine if the sector erase timer has timed out (See the section on DQ3: Sector Erase Timer.). The time-out begins from the rising edge of the final WE# pulse in the command sequence.

When the Embedded Erase algorithm is complete, the device returns to reading array data and addresses are no longer latched. The system can determine the status of the erase operation by reading DQ7, DQ6, or DQ2 in the erasing sector. Refer to the Write Operation Status section for information on these status bits.

Once the sector erase operation has begun, only the Erase Suspend command is valid. All other commands are ignored. However, note that a **hardware reset** immediately terminates the erase operation. If that occurs, the sector erase command sequence should be reinitiated once the device has returned to reading array data, to ensure data integrity.

Figure 6 illustrates the algorithm for the erase operation. Refer to the Erase and Program Operations tables in the AC Characteristics section for parameters, and Figure 20 section for timing diagrams.

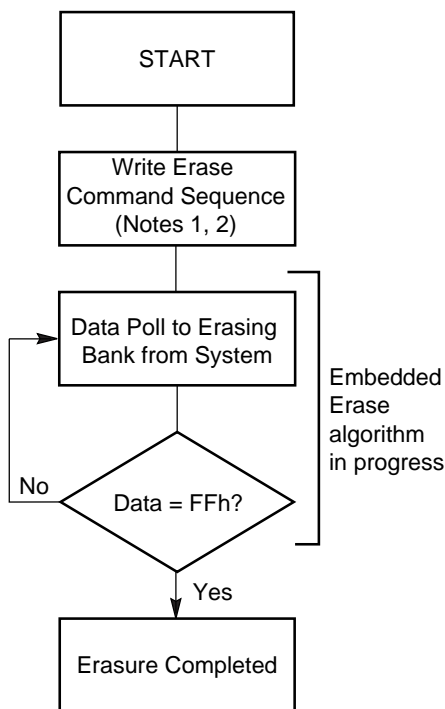

Figure 7. Erase Operation

Notes:

1. See Tables 10 and 11 for erase command sequence.
2. See the section on DQ3 for information on the sector erase timer.

Erase Suspend/Erase Resume Commands

The Erase Suspend command, B0h, allows the system to interrupt a sector erase operation and then read data from, or program data to, any sector not selected for erasure. This command is valid only during the sector erase operation, including the 50 μ s time-out period during the sector erase command sequence. The Erase Suspend command is ignored if written during the chip erase operation or Embedded Program algorithm.

When the Erase Suspend command is written during the sector erase operation, the device requires a typical of 5 μ s (maximum of 20 μ s) to suspend the erase operation. However, when the Erase Suspend command is written during the sector erase time-out, the device immediately terminates the time-out period and suspends the erase operation.

After the erase operation has been suspended, the device enters the erase-suspend-read mode. The system can read data from or program data to any sector not selected for erasure. (The device “erase suspends” all sectors selected for erasure.) Reading at any address within erase-suspended sectors produces status information on DQ7–DQ0. The system can use DQ7, or DQ6 and DQ2 together, to determine if a sector is actively erasing or is erase-suspended. Refer to the Write Operation Status section for information on these status bits.

After an erase-suspended program operation is complete, the device returns to the erase-suspend-read mode. The system can determine the status of the program operation using the DQ7 or DQ6 status bits, just as in the standard word program operation. Refer to the Write Operation Status section for more information.

In the erase-suspend-read mode, the system can also issue the autoselect command sequence. Refer to the Autoselect Mode and Autoselect Command Sequence sections for details.

To resume the sector erase operation, the system must write the Erase Resume command. The address of the erase-suspended sector is required when writing this command. Further writes of the Resume command are ignored. Another Erase Suspend command can be written after the chip has resumed erasing.

Command Definitions

Table 10. Command Definitions (x16 Mode, BYTE# = V_{IH})

Command Sequence (Note 1)	Cycles	Bus Cycles (Notes 2-5)												
		First		Second		Third		Fourth		Fifth		Sixth		
		Addr	Data	Addr	Data	Addr	Data	Addr	Data	Addr	Data	Addr	Data	
Read (Note 6)	1	RA	RD											
Reset (Note 7)	1	XXX	F0											
Autoselect (Note 8)	Manufacturer ID	4	555	AA	2AA	55	555	90	X00	0001				
	Device ID (Note 9)	4	555	AA	2AA	55	555	90	X01	227E	X0E	2212	X0F	2200
	SecSi™ Sector Factory Protect (Note 10)	4	555	AA	2AA	55	555	90	X03	(Note 10)				
	Sector Group Protect Verify (Note 12)	4	555	AA	2AA	55	555	90	(SA)X02	00/01				
Enter SecSi Sector Region	3	555	AA	2AA	55	555	88							
Exit SecSi Sector Region	4	555	AA	2AA	55	555	90	XXX	00					
Program	4	555	AA	2AA	55	555	A0	PA	PD					
Write to Buffer (Note 11)	3	555	AA	2AA	55	SA	25	SA	WC	PA	PD	WBL	PD	
Program Buffer to Flash	1	SA	29											
Write to Buffer Abort Reset (Note 13)	3	555	AA	2AA	55	555	F0							
Unlock Bypass	3	555	AA	2AA	55	555	20							
Unlock Bypass Program (Note 14)	2	XXX	A0	PA	PD									
Unlock Bypass Reset (Note 15)	2	XXX	90	XXX	00									
Chip Erase	6	555	AA	2AA	55	555	80	555	AA	2AA	55	555	10	
Sector Erase	6	555	AA	2AA	55	555	80	555	AA	2AA	55	SA	30	
Program/Erase Suspend (Note 16)	1	BA	B0											
Program/Erase Resume (Note 17)	1	BA	30											
CFI Query (Note 18)	1	55	98											

Legend:

X = Don't care

RA = Read Address of the memory location to be read.

RD = Read Data read from location RA during read operation.

PA = Program Address. Addresses latch on the falling edge of the WE# or CE# pulse, whichever happens later.

PD = Program Data for location PA. Data latches on the rising edge of WE# or CE# pulse, whichever happens first.

SA = Sector Address of sector to be verified (in autoselect mode) or erased. Address bits A22–A15 uniquely select any sector.

WBL = Write Buffer Location. Address must be within the same write buffer page as PA.

WC = Word Count. Number of write buffer locations to load minus 1.

Notes:

- See Table 1 for description of bus operations.
- All values are in hexadecimal.
- Except for the read cycle and the fourth cycle of the autoselect command sequence, all bus cycles are write cycles.
- Data bits DQ15–DQ8 are don't care in command sequences, except for RD, PD, and WC.
- Unless otherwise noted, address bits A22–A11 are don't cares.
- No unlock or command cycles required when device is in read mode.
- The Reset command is required to return to the read mode (or to the erase-suspend-read mode if previously in Erase Suspend) when the device is in the autoselect mode, or if DQ5 goes high while the device is providing status information.
- The fourth cycle of the autoselect command sequence is a read cycle. Data bits DQ15–DQ8 are don't care. See the Autoselect Command Sequence section for more information.
- The device ID must be read in three cycles.
- If WP# protects the highest address sector, the data is 98h for factory locked and 18h for not factory locked. If WP# protects the

lowest address sector, the data is 88h for factory locked and 08h for not factor locked.

- The total number of cycles in the command sequence is determined by the number of words written to the write buffer. The maximum number of cycles in the command sequence is 21.
- The data is 00h for an unprotected sector and 01h for a protected sector.
- Command sequence resets device for next command after aborted write-to-buffer operation.
- The Unlock Bypass command is required prior to the Unlock Bypass Program command.
- The Unlock Bypass Reset command is required to return to the read mode when the device is in the unlock bypass mode.
- The system may read and program in non-erasing sectors, or enter the autoselect mode, when in the Erase Suspend mode. The Erase Suspend command is valid only during a sector erase operation.
- The Erase Resume command is valid only during the Erase Suspend mode.
- Command is valid when device is ready to read array data or when device is in autoselect mode.

Table 11. Command Definitions (x8 Mode, BYTE# = V_{IL})

Command Sequence (Note 1)	Cycles	Bus Cycles (Notes 2–5)											
		First		Second		Third		Fourth		Fifth		Sixth	
		Addr	Data	Addr	Data	Addr	Data	Addr	Data	Addr	Data	Addr	Data
Read (Note 6)	1	RA	RD										
Reset (Note 7)	1	XXX	F0										
Autoselect (Note 8)	Manufacturer ID	4	AAA	AA	555	55	AAA	90	X00	01			
	Device ID (Note 9)	4	AAA	AA	555	55	AAA	90	X02	7E	X1C	12	X1E 00
	SecSi™ Sector Factory Protect (Note 10)	4	AAA	AA	555	55	AAA	90	X06	(Note 10)			
	Sector Group Protect Verify (Note 12)	4	AAA	AA	555	55	AAA	90	(SA)X04	00/01			
Enter SecSi Sector Region	3	AAA	AA	555	55	AAA	88						
Exit SecSi Sector Region	4	AAA	AA	555	55	AAA	90	XXX	00				
Program	4	AAA	AA	555	55	AAA	A0	PA	PD				
Write to Buffer (Note 11)	3	AAA	AA	555	55	SA	25	SA	BC	PA	PD	WBL PD	
Program Buffer to Flash	1	SA	29										
Write to Buffer Abort Reset (Note 13)	3	AAA	AA	555	55	AAA	F0						
Unlock Bypass	3	AAA	AA	555	55	AAA	20						
Unlock Bypass Program (Note 14)	2	XXX	A0	PA	PD								
Unlock Bypass Reset (Note 15)	2	XXX	90	XXX	00								
Chip Erase	6	AAA	AA	555	55	AAA	80	AAA	AA	555	55	AAA 10	
Sector Erase	6	AAA	AA	555	55	AAA	80	AAA	AA	555	55	SA 30	
Program/Erase Suspend (Note 16)	1	BA	B0										
Program/Erase Resume (Note 17)	1	BA	30										
CFI Query (Note 18)	1	AA	98										

Legend:

X = Don't care

RA = Read Address of the memory location to be read.

RD = Read Data read from location RA during read operation.

PA = Program Address. Addresses latch on the falling edge of the WE# or CE# pulse, whichever happens later.

PD = Program Data for location PA. Data latches on the rising edge of WE# or CE# pulse, whichever happens first.

SA = Sector Address of sector to be verified (in autoselect mode) or erased. Address bits A22–A15 uniquely select any sector.

WBL = Write Buffer Location. Address must be within the same write buffer page as PA.

BC = Byte Count. Number of write buffer locations to load minus 1.

Notes:

- See Table 1 for description of bus operations.
- All values are in hexadecimal.
- Except for the read cycle and the fourth cycle of the autoselect command sequence, all bus cycles are write cycles.
- Data bits DQ15–DQ8 are don't care in command sequences, except for RD and PD.
- Unless otherwise noted, address bits A22–A11 are don't cares.
- No unlock or command cycles required when device is in read mode.
- The Reset command is required to return to the read mode (or to the erase-suspend-read mode if previously in Erase Suspend) when the device is in the autoselect mode, or if DQ5 goes high while the device is providing status information.
- The fourth cycle of the autoselect command sequence is a read cycle. Data bits DQ15–DQ8 are don't care. See the Autoselect Command Sequence section for more information.
- The device ID must be read in three cycles.
- If WP# protects the highest address sector, the data is 98h for factory locked and 18h for not factory locked. If WP# protects the

lowest address sector, the data is 88h for factory locked and 08h for not factor locked.

- The total number of cycles in the command sequence is determined by the number of words written to the write buffer. The maximum number of cycles in the command sequence is 37.
- The data is 00h for an unprotected sector group and 01h for a protected sector group.
- Command sequence resets device for next command after aborted write-to-buffer operation.
- The Unlock Bypass command is required prior to the Unlock Bypass Program command.
- The Unlock Bypass Reset command is required to return to the read mode when the device is in the unlock bypass mode.
- The system may read and program in non-erasing sectors, or enter the autoselect mode, when in the Erase Suspend mode. The Erase Suspend command is valid only during a sector erase operation.
- The Erase Resume command is valid only during the Erase Suspend mode.
- Command is valid when device is ready to read array data or when device is in autoselect mode.

WRITE OPERATION STATUS

The device provides several bits to determine the status of a program or erase operation: DQ2, DQ3, DQ5, DQ6, and DQ7. Table 12 and the following subsections describe the function of these bits. DQ7 and DQ6 each offer a method for determining whether a program or erase operation is complete or in progress. The device also provides a hardware-based output signal, RY/BY#, to determine whether an Embedded Program or Erase operation is in progress or has been completed.

DQ7: Data# Polling

The Data# Polling bit, DQ7, indicates to the host system whether an Embedded Program or Erase algorithm is in progress or completed, or whether the device is in Erase Suspend. Data# Polling is valid after the rising edge of the final WE# pulse in the command sequence.

During the Embedded Program algorithm, the device outputs on DQ7 the complement of the datum programmed to DQ7. This DQ7 status also applies to programming during Erase Suspend. When the Embedded Program algorithm is complete, the device outputs the datum programmed to DQ7. The system must provide the program address to read valid status information on DQ7. If a program address falls within a protected sector, Data# Polling on DQ7 is active for approximately 1 μ s, then the device returns to the read mode.

During the Embedded Erase algorithm, Data# Polling produces a "0" on DQ7. When the Embedded Erase algorithm is complete, or if the device enters the Erase Suspend mode, Data# Polling produces a "1" on DQ7. The system must provide an address within any of the sectors selected for erasure to read valid status information on DQ7.

After an erase command sequence is written, if all sectors selected for erasing are protected, Data# Polling on DQ7 is active for approximately 100 μ s, then the device returns to the read mode. If not all selected sectors are protected, the Embedded Erase algorithm erases the unprotected sectors, and ignores the selected sectors that are protected. However, if the system reads DQ7 at an address within a protected sector, the status may not be valid.

Just prior to the completion of an Embedded Program or Erase operation, DQ7 may change asynchronously with DQ0–DQ6 while Output Enable (OE#) is asserted low. That is, the device may change from providing status information to valid data on DQ7. Depending on when the system samples the DQ7 output, it may read the status or valid data. Even if the device has completed the program or erase operation and DQ7 has

valid data, the data outputs on DQ0–DQ6 may be still invalid. Valid data on DQ0–DQ7 will appear on successive read cycles.

Table 12 shows the outputs for Data# Polling on DQ7. Figure 8 shows the Data# Polling algorithm. Figure 21 in the AC Characteristics section shows the Data# Polling timing diagram.

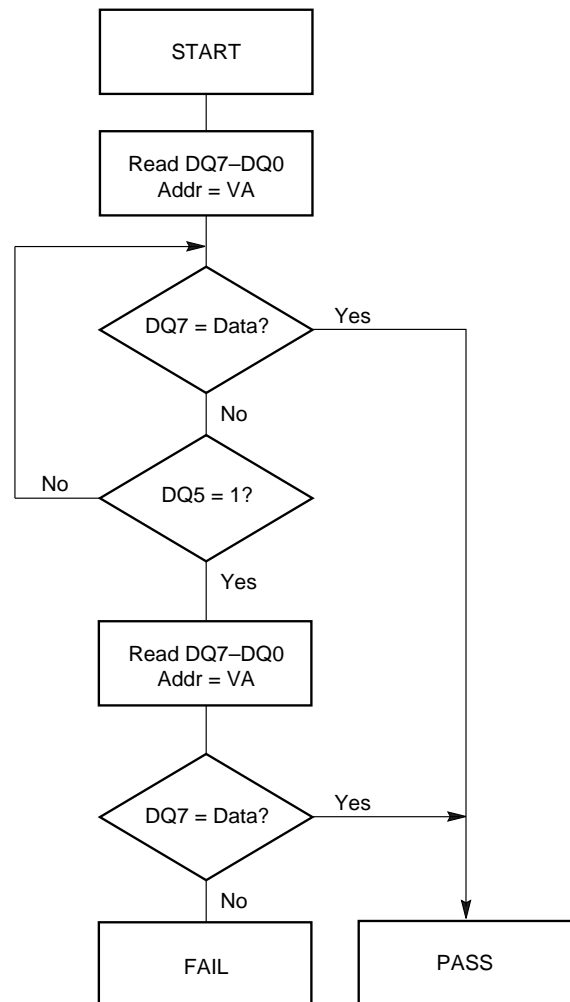

Notes:

1. VA = Valid address for programming. During a sector erase operation, a valid address is any sector address within the sector being erased. During chip erase, a valid address is any non-protected sector address.
2. DQ7 should be rechecked even if DQ5 = "1" because DQ7 may change simultaneously with DQ5.

Figure 8. Data# Polling Algorithm

RY/BY#: Ready/Busy#

The RY/BY# is a dedicated, open-drain output pin which indicates whether an Embedded Algorithm is in progress or complete. The RY/BY# status is valid after the rising edge of the final WE# pulse in the command sequence. Since RY/BY# is an open-drain output, several RY/BY# pins can be tied together in parallel with a pull-up resistor to V_{CC} .

If the output is low (Busy), the device is actively erasing or programming. (This includes programming in the Erase Suspend mode.) If the output is high (Ready), the device is in the read mode, the standby mode, or in the erase-suspend-read mode. Table 12 shows the outputs for RY/BY#.

DQ6: Toggle Bit I

Toggle Bit I on DQ6 indicates whether an Embedded Program or Erase algorithm is in progress or complete, or whether the device has entered the Erase Suspend mode. Toggle Bit I may be read at any address, and is valid after the rising edge of the final WE# pulse in the command sequence (prior to the program or erase operation), and during the sector erase time-out.

During an Embedded Program or Erase algorithm operation, successive read cycles to any address cause DQ6 to toggle. The system may use either OE# or CE# to control the read cycles. When the operation is complete, DQ6 stops toggling.

After an erase command sequence is written, if all sectors selected for erasing are protected, DQ6 toggles for approximately 100 μ s, then returns to reading array data. If not all selected sectors are protected, the Embedded Erase algorithm erases the unprotected sectors, and ignores the selected sectors that are protected.

The system can use DQ6 and DQ2 together to determine whether a sector is actively erasing or is erase-suspended. When the device is actively erasing (that is, the Embedded Erase algorithm is in progress), DQ6 toggles. When the device enters the Erase Suspend mode, DQ6 stops toggling. However, the system must also use DQ2 to determine which sectors are erasing or erase-suspended. Alternatively, the system can use DQ7 (see the subsection on DQ7: Data# Polling).

If a program address falls within a protected sector, DQ6 toggles for approximately 1 μ s after the program command sequence is written, then returns to reading array data.

DQ6 also toggles during the erase-suspend-program mode, and stops toggling once the Embedded Program algorithm is complete.

Table 12 shows the outputs for Toggle Bit I on DQ6. Figure 9 shows the toggle bit algorithm. Figure 22 in the "AC Characteristics" section shows the toggle bit timing diagrams. Figure 23 shows the differences between DQ2 and DQ6 in graphical form. See also the subsection on DQ2: Toggle Bit II.

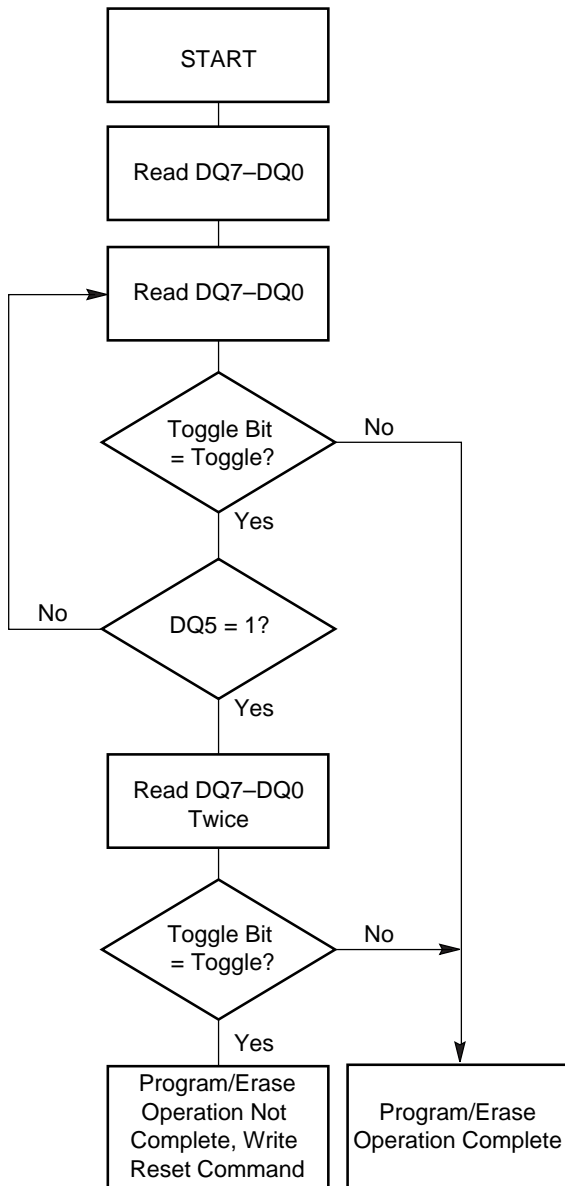

Note: The system should recheck the toggle bit even if $DQ5 = "1"$ because the toggle bit may stop toggling as $DQ5$ changes to "1." See the subsections on $DQ6$ and $DQ2$ for more information.

Figure 9. Toggle Bit Algorithm

DQ2: Toggle Bit II

The "Toggle Bit II" on $DQ2$, when used with $DQ6$, indicates whether a particular sector is actively erasing (that is, the Embedded Erase algorithm is in progress), or whether that sector is erase-suspended. Toggle Bit II is valid after the rising edge of the final $WE\#$ pulse in the command sequence.

$DQ2$ toggles when the system reads at addresses within those sectors that have been selected for erasure. (The system may use either $OE\#$ or $CE\#$ to control the read cycles.) But $DQ2$ cannot distinguish whether the sector is actively erasing or is erase-suspended. $DQ6$, by comparison, indicates whether the device is actively erasing, or is in Erase Suspend, but cannot distinguish which sectors are selected for erasure. Thus, both status bits are required for sector and mode information. Refer to Table 12 to compare outputs for $DQ2$ and $DQ6$.

Figure 9 shows the toggle bit algorithm in flowchart form, and the section "DQ2: Toggle Bit II" explains the algorithm. See also the $RY/BY\#$: Ready/Busy# subsection. Figure 22 shows the toggle bit timing diagram. Figure 23 shows the differences between $DQ2$ and $DQ6$ in graphical form.

Reading Toggle Bits $DQ6/DQ2$

Refer to Figure 9 for the following discussion. Whenever the system initially begins reading toggle bit status, it must read $DQ7-DQ0$ at least twice in a row to determine whether a toggle bit is toggling. Typically, the system would note and store the value of the toggle bit after the first read. After the second read, the system would compare the new value of the toggle bit with the first. If the toggle bit is not toggling, the device has completed the program or erase operation. The system can read array data on $DQ7-DQ0$ on the following read cycle.

However, if after the initial two read cycles, the system determines that the toggle bit is still toggling, the system also should note whether the value of $DQ5$ is high (see the section on $DQ5$). If it is, the system should then determine again whether the toggle bit is toggling, since the toggle bit may have stopped toggling just as $DQ5$ went high. If the toggle bit is no longer toggling, the device has successfully completed the program or erase operation. If it is still toggling, the device did not complete the operation successfully, and the system must write the reset command to return to reading array data.

The remaining scenario is that the system initially determines that the toggle bit is toggling and $DQ5$ has not gone high. The system may continue to monitor the toggle bit and $DQ5$ through successive read cycles, determining the status as described in the previous paragraph. Alternatively, it may choose to perform

other system tasks. In this case, the system must start at the beginning of the algorithm when it returns to determine the status of the operation (top of Figure 9).

DQ5: Exceeded Timing Limits

DQ5 indicates whether the program, erase, or write-to-buffer time has exceeded a specified internal pulse count limit. Under these conditions DQ5 produces a “1,” indicating that the program or erase cycle was not successfully completed.

The device may output a “1” on DQ5 if the system tries to program a “1” to a location that was previously programmed to “0.” **Only an erase operation can change a “0” back to a “1.”** Under this condition, the device halts the operation, and when the timing limit has been exceeded, DQ5 produces a “1.”

In all these cases, the system must write the reset command to return the device to the reading the array (or to erase-suspend-read if the device was previously in the erase-suspend-program mode).

DQ3: Sector Erase Timer

After writing a sector erase command sequence, the system may read DQ3 to determine whether or not erasure has begun. (The sector erase timer does not apply to the chip erase command.) If additional sectors are selected for erasure, the entire time-out also applies after each additional sector erase com-

mand. When the time-out period is complete, DQ3 switches from a “0” to a “1.” If the time between additional sector erase commands from the system can be assumed to be less than 50 μ s, the system need not monitor DQ3. See also the Sector Erase Command Sequence section.

After the sector erase command is written, the system should read the status of DQ7 (Data# Polling) or DQ6 (Toggle Bit I) to ensure that the device has accepted the command sequence, and then read DQ3. If DQ3 is “1,” the Embedded Erase algorithm has begun; all further commands (except Erase Suspend) are ignored until the erase operation is complete. If DQ3 is “0,” the device will accept additional sector erase commands. To ensure the command has been accepted, the system software should check the status of DQ3 prior to and following each subsequent sector erase command. If DQ3 is high on the second status check, the last command might not have been accepted.

Table 12 shows the status of DQ3 relative to the other status bits.

DQ1: Write-to-Buffer Abort

DQ1 indicates whether a Write-to-Buffer operation was aborted. Under these conditions DQ1 produces a “1”. The system must issue the Write-to-Buffer-Abort-Reset command sequence to return the device to reading array data. See Write Buffer Programming section for more details.

Table 12. Write Operation Status

Status			DQ7 (Note 2)	DQ6	DQ5 (Note 1)	DQ3	DQ2 (Note 2)	DQ1	RY/BY#
Standard Mode	Embedded Program Algorithm		DQ7#	Toggle	0	N/A	No toggle	0	0
	Embedded Erase Algorithm		0	Toggle	0	1	Toggle	N/A	0
Program Suspend Mode	Program-Suspend Read	Program-Suspended Sector	Invalid (not allowed)						1
		Non-Program Suspended Sector	Data						1
Erase Suspend Mode	Erase-Suspend Read	Erase-Suspended Sector	1	No toggle	0	N/A	Toggle	N/A	1
		Non-Erase Suspended Sector	Data						1
	Erase-Suspend-Program (Embedded Program)		DQ7#	Toggle	0	N/A	N/A	N/A	0
Write-to-Buffer	Busy (Note 3)		DQ7#	Toggle	0	N/A	N/A	0	0
	Abort (Note 4)		DQ7#	Toggle	0	N/A	N/A	1	0

Notes:

1. DQ5 switches to '1' when an Embedded Program, Embedded Erase, or Write-to-Buffer operation has exceeded the maximum timing limits. Refer to the section on DQ5 for more information.
2. DQ7 and DQ2 require a valid address when reading status information. Refer to the appropriate subsection for further details.
3. The Data# Polling algorithm should be used to monitor the last loaded write-buffer address location.
4. DQ1 switches to '1' when the device has aborted the write-to-buffer operation.

ABSOLUTE MAXIMUM RATINGS

Storage Temperature	
Plastic Packages	−65°C to +150°C
Ambient Temperature with Power Applied	−65°C to +125°C
Voltage with Respect to Ground	
V_{CC} (Note 1)	−0.5 V to +4.0 V
V_{IO}	−0.5 V to +4.0 V
A9, OE#, ACC, and RESET# (Note 2)	−0.5 V to +12.5 V
All other pins (Note 1)	−0.5 V to $V_{CC} + 0.5$ V
Output Short Circuit Current (Note 3)	200 mA

Notes:

1. Minimum DC voltage on input or I/O pins is −0.5 V. During voltage transitions, input or I/O pins may overshoot V_{SS} to −2.0 V for periods of up to 20 ns. Maximum DC voltage on input or I/O pins is $V_{CC} + 0.5$ V. See Figure 10. During voltage transitions, input or I/O pins may overshoot to $V_{CC} + 2.0$ V for periods up to 20 ns. See Figure 11.
2. Minimum DC input voltage on pins A9, OE#, ACC, and RESET# is −0.5 V. During voltage transitions, A9, OE#, ACC, and RESET# may overshoot V_{SS} to −2.0 V for periods of up to 20 ns. See Figure 10. Maximum DC input voltage on pin A9, OE#, ACC, and RESET# is +12.5 V which may overshoot to +14.0 V for periods up to 20 ns.
3. No more than one output may be shorted to ground at a time. Duration of the short circuit should not be greater than one second.

Stresses above those listed under “Absolute Maximum Ratings” may cause permanent damage to the device. This is a stress rating only; functional operation of the device at these or any other conditions above those indicated in the operational sections of this data sheet is not implied. Exposure of the device to absolute maximum rating conditions for extended periods may affect device reliability.

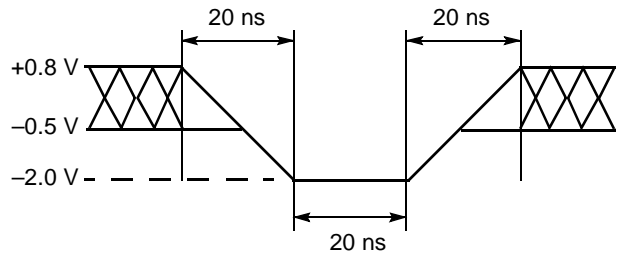

Figure 10. Maximum Negative Overshoot Waveform

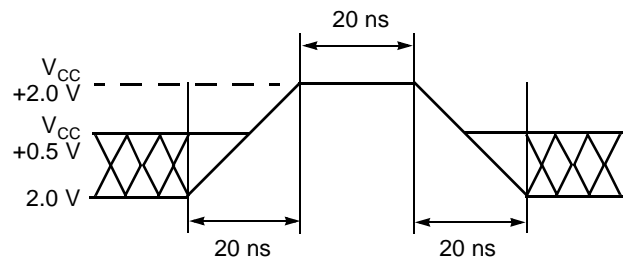

Figure 11. Maximum Positive Overshoot Waveform

OPERATING RANGES

Industrial (I) Devices

Ambient Temperature (T_A)	−40°C to +85°C
-------------------------------	----------------

Supply Voltages

V_{CC} (regulated voltage range)	3.0–3.6 V
V_{CC} (full voltage range)	2.7–3.6 V
V_{IO} (Note 2)	1.65–3.6 V (Note 3)

Notes:

1. Operating ranges define those limits between which the functionality of the device is guaranteed.
2. See Ordering Information section for valid V_{CC}/V_{IO} range combinations. The I/Os will not operate at 3V when $V_{IO} = 1.8V$.
3. 100R/100 Full parts have a V_{IO} range from 2.7–3.6 V.

DC CHARACTERISTICS
CMOS Compatible

Parameter Symbol	Parameter Description (Notes)	Test Conditions	Min	Typ	Max	Unit
I_{LI}	Input Load Current (1)	$V_{IN} = V_{SS}$ to V_{CC} , $V_{CC} = V_{CC\ max}$			± 1.0	μA
I_{LIT}	A9, ACC Input Load Current	$V_{CC} = V_{CC\ max}$; A9 = 12.5 V			35	μA
I_{LO}	Output Leakage Current	$V_{OUT} = V_{SS}$ to V_{CC} , $V_{CC} = V_{CC\ max}$			± 1.0	μA
I_{LR}	Reset Leakage Current	$V_{CC} = V_{CC\ max}$; RESET# = 12.5 V			35	μA
I_{CC1}	V_{CC} Active Read Current (2, 3)	CE# = V_{IL} , OE# = V_{IH}	5 MHz	15	20	mA
			1 MHz	15	20	
I_{CC2}	V_{CC} Initial Page Read Current (2, 3)	CE# = V_{IL} , OE# = V_{IH}		30	50	mA
I_{CC3}	V_{CC} Intra-Page Read Current (2, 3)	CE# = V_{IL} , OE# = V_{IH}		10	20	mA
I_{CC4}	V_{CC} Active Write Current (3, 4)	CE# = V_{IL} , OE# = V_{IH}		50	60	mA
I_{CC5}	V_{CC} Standby Current (3)	CE#, RESET# = $V_{CC} \pm 0.3$ V, WP# = V_{IH}		1	5	μA
I_{CC6}	V_{CC} Reset Current (3)	RESET# = $V_{SS} \pm 0.3$ V, WP# = V_{IH}		1	5	μA
I_{CC7}	Automatic Sleep Mode (3, 5)	$V_{IH} = V_{CC} \pm 0.3$ V; $V_{IL} = V_{SS} \pm 0.3$ V, WP# = V_{IH}		1	5	μA
V_{IL1}	Input Low Voltage 1 (6, 7)		-0.5		0.8	V
V_{IH1}	Input High Voltage 1 (6, 7)		1.9		$V_{CC} + 0.5$	V
V_{IL2}	Input Low Voltage 2 (6, 8)		-0.5		$0.3 \times V_{IO}$	V
V_{IH2}	Input High Voltage 2 (6, 8)		1.9		$V_{IO} + 0.5$	V
V_{HH}	Voltage for ACC Program Acceleration	$V_{CC} = 2.7-3.6$ V	11.5		12.5	V
V_{ID}	Voltage for Autoselect and Temporary Sector Unprotect	$V_{CC} = 2.7-3.6$ V	11.5		12.5	V
V_{OL}	Output Low Voltage (10)	$I_{OL} = 4.0$ mA, $V_{CC} = V_{CC\ min} = V_{IO}$			$0.15 \times V_{IO}$	V
V_{OH1}	Output High Voltage	$I_{OH} = -2.0$ mA, $V_{CC} = V_{CC\ min} = V_{IO}$	$0.85 V_{IO}$			V
V_{OH2}		$I_{OH} = -100$ μA , $V_{CC} = V_{CC\ min} = V_{IO}$	$V_{IO} - 0.4$			V
V_{LKO}	Low V_{CC} Lock-Out Voltage (9)		2.3		2.5	V

Notes:

- On the WP#/ACC pin only, the maximum input load current when WP# = V_{IL} is ± 5.0 μA .
- The I_{CC} current listed is typically less than 2 mA/MHz, with OE# at V_{IH} .
- Maximum I_{CC} specifications are tested with $V_{CC} = V_{CC\ max}$.
- I_{CC} active while Embedded Erase or Embedded Program is in progress.
- Automatic sleep mode enables the low power mode when addresses remain stable for $t_{ACC} + 30$ ns.
- If $V_{IO} < V_{CC}$, maximum V_{IL} for CE# and DQ I/Os is $0.3 V_{IO}$. Maximum V_{IH} for these connections is $V_{IO} + 0.3$ V.
- V_{CC} voltage requirements.
- V_{IO} voltage requirements.
- Not 100% tested.
- Includes RY/BY#

TEST CONDITIONS

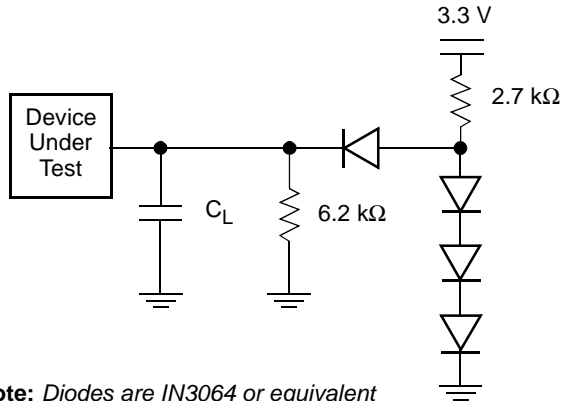

Note: Diodes are IN3064 or equivalent
Figure 12. Test Setup

Table 13. Test Specifications

Test Condition	All Speeds	Unit
Output Load	1 TTL gate	
Output Load Capacitance, C_L (including jig capacitance)	30	pF
Input Rise and Fall Times	5	ns
Input Pulse Levels	0.0–3.0	V
Input timing measurement reference levels (See Note)	1.5	V
Output timing measurement reference levels	$0.5 V_{IO}$	V

Note: If $V_{IO} < V_{CC}$, the reference level is $0.5 V_{IO}$.

KEY TO SWITCHING WAVEFORMS

WAVEFORM	INPUTS	OUTPUTS
		Steady
		Changing from H to L
		Changing from L to H
	Don't Care, Any Change Permitted	Changing, State Unknown
	Does Not Apply	Center Line is High Impedance State (High Z)

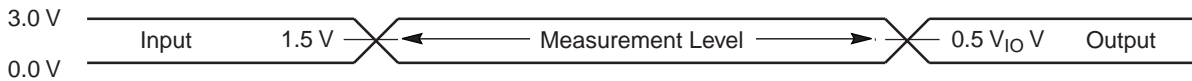

Note: If $V_{IO} < V_{CC}$, the input measurement reference level is $0.5 V_{IO}$.

Figure 13. Input Waveforms and Measurement Levels

AC CHARACTERISTICS

Read-Only Operations

Parameter		Description	Test Setup		Speed Options					Unit
JEDEC	Std.				103, 103R	113	113R	123	123R	
t_{AVAV}	t_{RC}	Read Cycle Time (Note 1)		Min	100	110	120		ns	
t_{AVQV}	t_{ACC}	Address to Output Delay	CE#, OE# = V_{IL}	Max	100	110	120		ns	
t_{ELQV}	t_{CE}	Chip Enable to Output Delay	OE# = V_{IL}	Max	100	110	120		ns	
	t_{PACC}	Page Access Time		Max	30	30	40	30	40	ns
t_{GLQV}	t_{OE}	Output Enable to Output Delay		Max	30	30	40	30	40	ns
t_{EHQZ}	t_{DF}	Chip Enable to Output High Z (Note 1)		Max	16				ns	
t_{GHQZ}	t_{DF}	Output Enable to Output High Z (Note 1)		Max	16				ns	
t_{AXQX}	t_{OH}	Output Hold Time From Addresses, CE# or OE#, Whichever Occurs First		Min	0				ns	
	t_{OEHL}	Output Enable Hold Time (Note 1)	Read	Min	0				ns	
		Toggle and Data# Polling		Min	10				ns	

Notes:

1. Not 100% tested.
2. See Figure 12 and Table 13 for test specifications.
3. AC Specifications listed are tested with $V_{IO} = V_{CC}$. Contact AMD for information on AC operation with $V_{IO} \neq V_{CC}$.

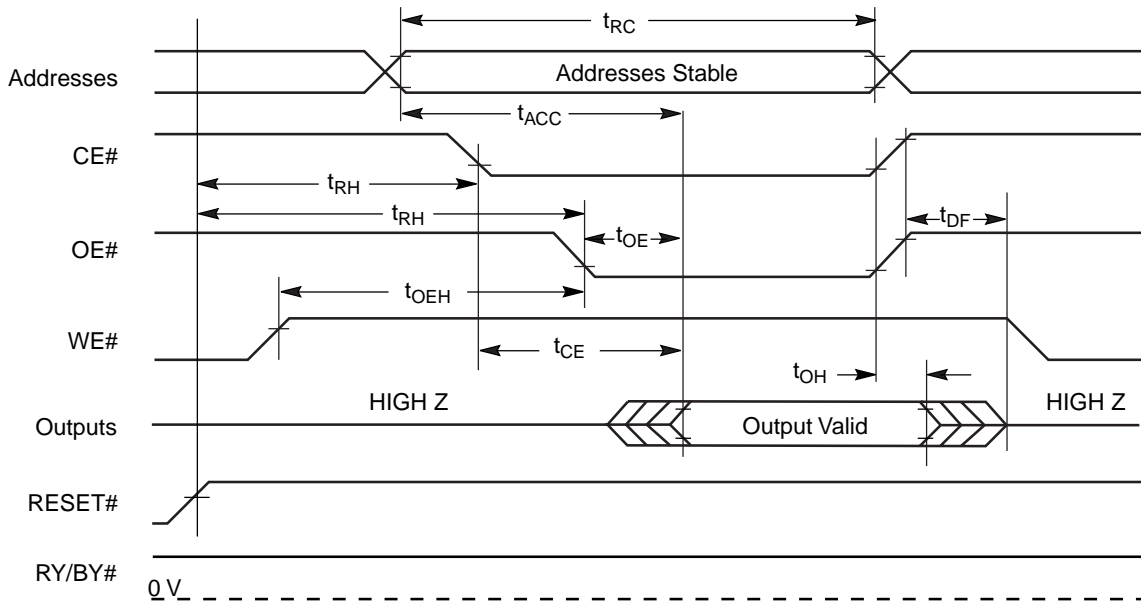
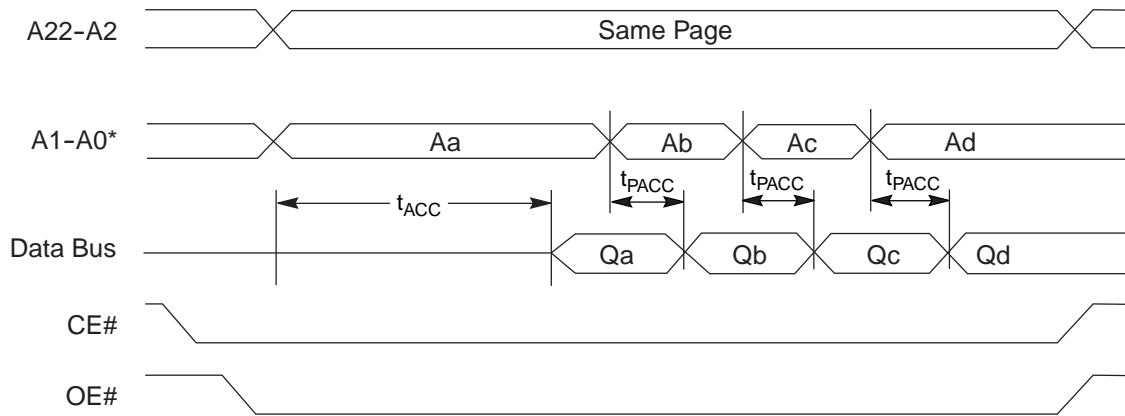

Figure 14. Read Operation Timings

AC CHARACTERISTICS



* Figure shows word mode. Addresses are A1–A-1 for byte mode.

Figure 15. Page Read Timings

AC CHARACTERISTICS

Hardware Reset (RESET#)

Parameter		Description		All Speed Options	Unit
JEDEC	Std.				
	t_{Ready}	RESET# Pin Low (During Embedded Algorithms) to Read Mode (See Note)	Max	20	μs
	t_{Ready}	RESET# Pin Low (NOT During Embedded Algorithms) to Read Mode (See Note)	Max	500	ns
	t_{RP}	RESET# Pulse Width	Min	500	ns
	t_{RH}	Reset High Time Before Read (See Note)	Min	50	ns
	t_{RPD}	RESET# Low to Standby Mode	Min	20	μs

Note:

1. Not 100% tested.
2. AC Specifications listed are tested with $V_{IO} = V_{CC}$. Contact AMD for information on AC operation with $V_{IO} \neq V_{CC}$.

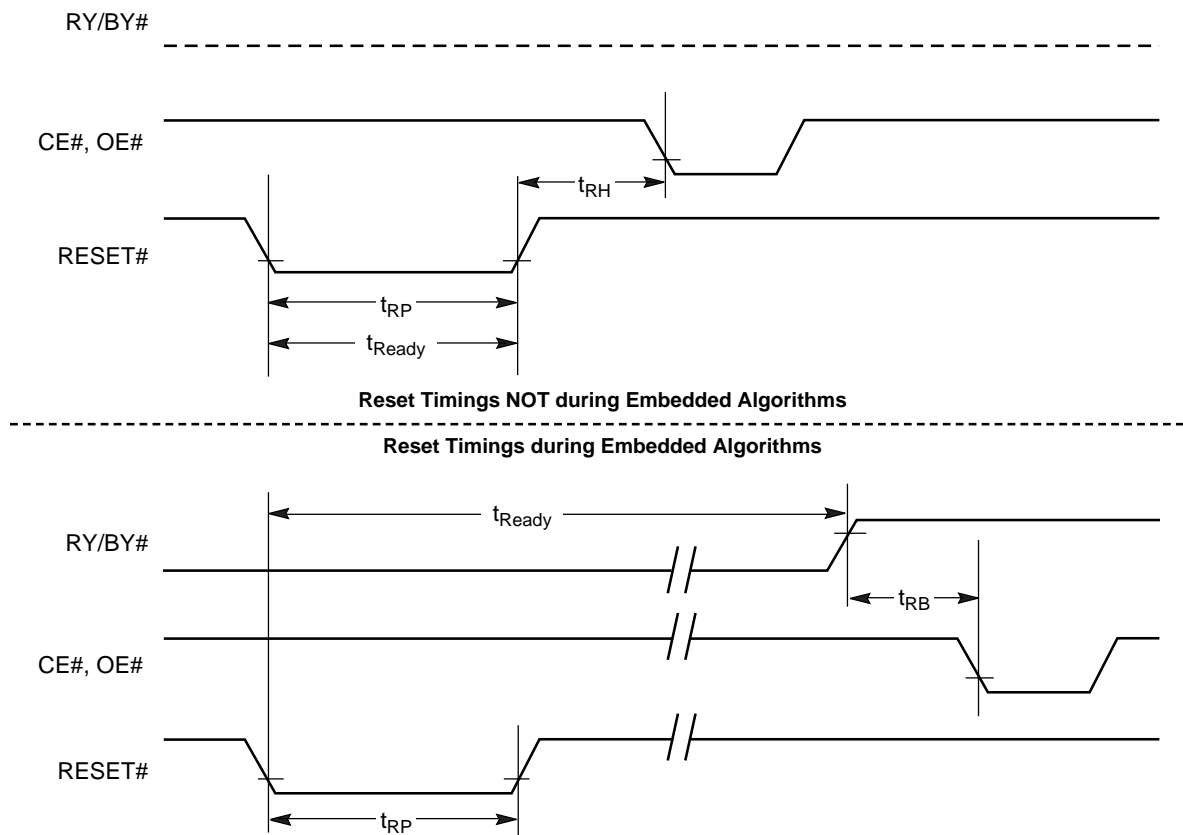

Figure 16. Reset Timings

AC CHARACTERISTICS

Erase and Program Operations

Parameter		Description		Speed Options			Unit	
JEDEC	Std.			103, 103R	113, 113R	123, 123R		
t_{AVAV}	t_{WC}	Write Cycle Time (Note 1)	Min	100	110	120	ns	
t_{AVWL}	t_{AS}	Address Setup Time	Min	0			ns	
	t_{ASO}	Address Setup Time to OE# low during toggle bit polling	Min	15			ns	
t_{WLAX}	t_{AH}	Address Hold Time	Min	45			ns	
	t_{AHT}	Address Hold Time From CE# or OE# high during toggle bit polling	Min	0			ns	
t_{DVWH}	t_{DS}	Data Setup Time	Min	45			ns	
t_{WHDX}	t_{DH}	Data Hold Time	Min	0			ns	
	t_{OEPH}	Output Enable High during toggle bit polling	Min	20			ns	
t_{GHWL}	t_{GHWL}	Read Recovery Time Before Write (OE# High to WE# Low)	Min	0			ns	
t_{ELWL}	t_{CS}	CE# Setup Time	Min	0			ns	
t_{WHEH}	t_{CH}	CE# Hold Time	Min	0			ns	
t_{WLWH}	t_{WP}	Write Pulse Width	Min	35			ns	
t_{WHDL}	t_{WPH}	Write Pulse Width High	Min	30			ns	
t_{WHWH1}	t_{WHWH1}	Write Buffer Program Operation (Notes 2, 3)	Typ	240			μ s	
		Effective Write Buffer Program Operation (Notes 2, 4)	Per Byte	Typ	7.5			μ s
			Per Word	Typ	15			μ s
		Accelerated Effective Write Buffer Program Operation (Notes 2, 4)	Per Byte	Typ	5.9			μ s
			Per Word	Typ	11.8			μ s
		Single Byte Word Program Operation (Note 2, 5)	Byte	Typ	60			μ s
			Word	Typ	60			μ s
Accelerated Single Byte Word Programming Operation (Note 2, 5)	Byte	Typ	54			μ s		
	Word	Typ	54			μ s		
t_{WHWH2}	t_{WHWH2}	Sector Erase Operation (Note 2)	Typ	0.5			sec	
	t_{VHH}	V_{HH} Rise and Fall Time (Note 1)	Min	250			ns	
	t_{VCS}	V_{CC} Setup Time (Note 1)	Min	50			μ s	

Notes:

1. Not 100% tested.
2. See the "Erase And Programming Performance" section for more information.
3. For 1–16 words/1–32 bytes programmed.
4. Effective write buffer specification is based upon a 16-word/32-byte write buffer operation
5. Byte/Word programming specification is based upon a single word/byte programming operation not utilizing the write buffer.
6. AC Specifications listed are tested with $V_{IO} = V_{CC}$. Contact AMD for information on AC operation with $V_{IO} \neq V_{CC}$.

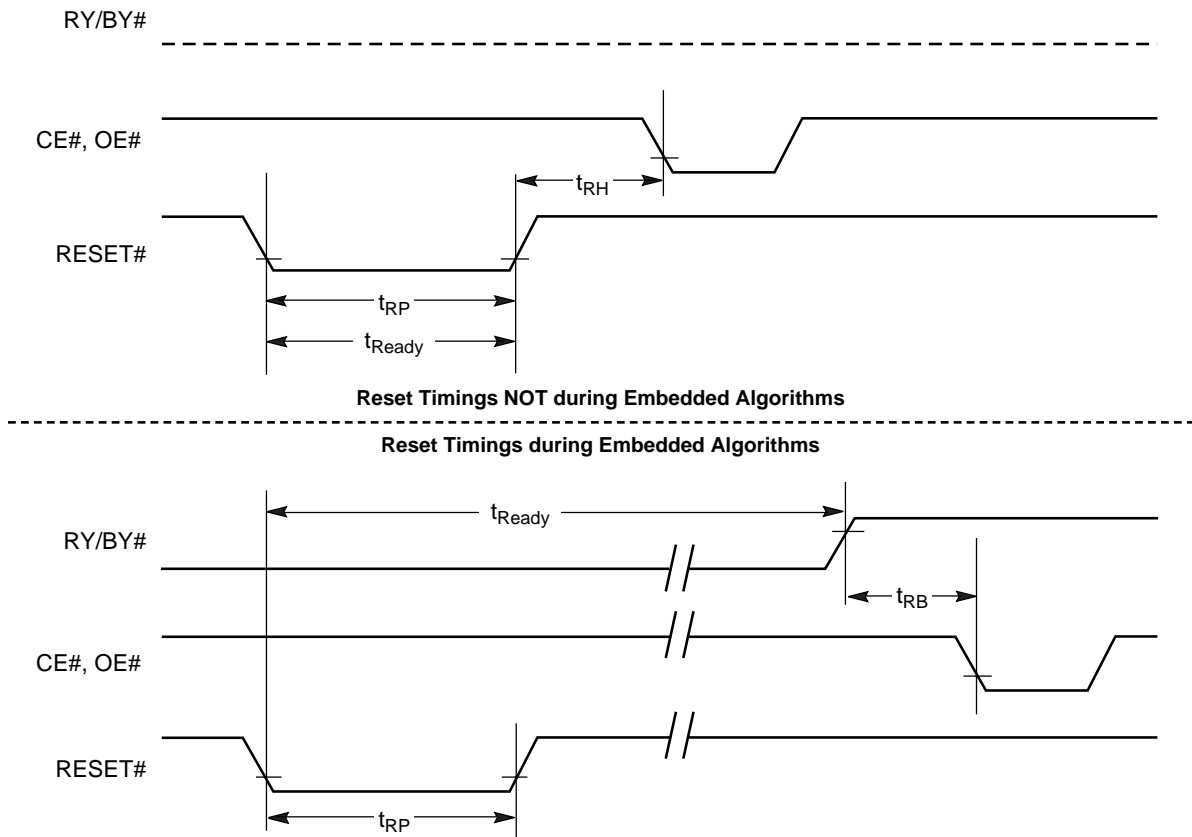
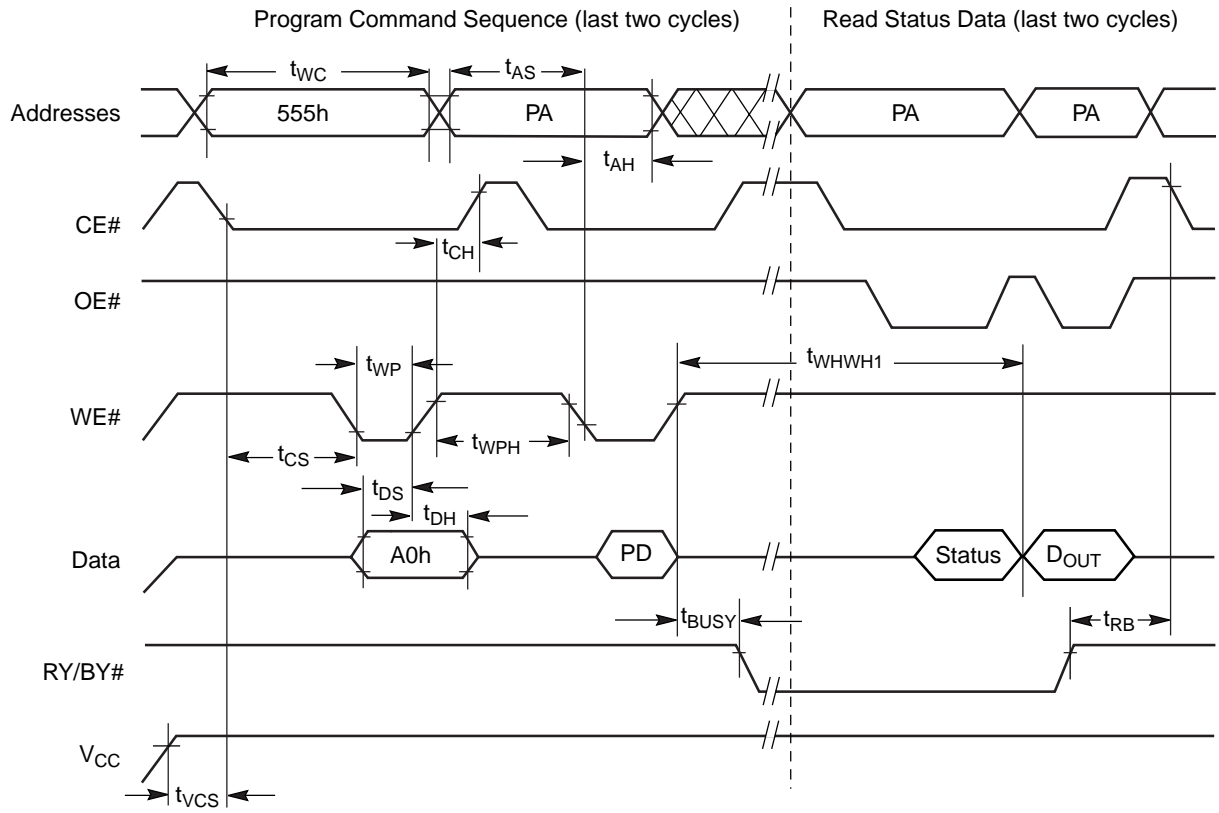

Figure 17. Reset Timings

AC CHARACTERISTICS



Notes:

1. PA = program address, PD = program data, D_{OUT} is the true data at the program address.
2. Illustration shows device in word mode.

Figure 18. Program Operation Timings

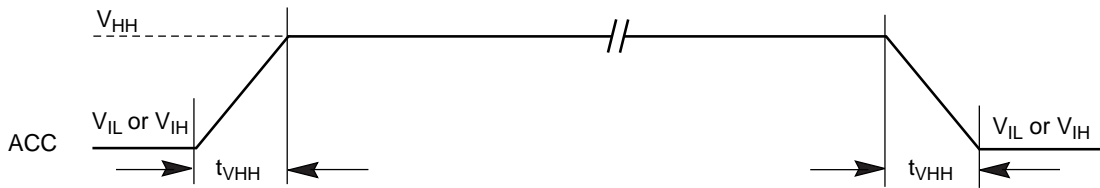
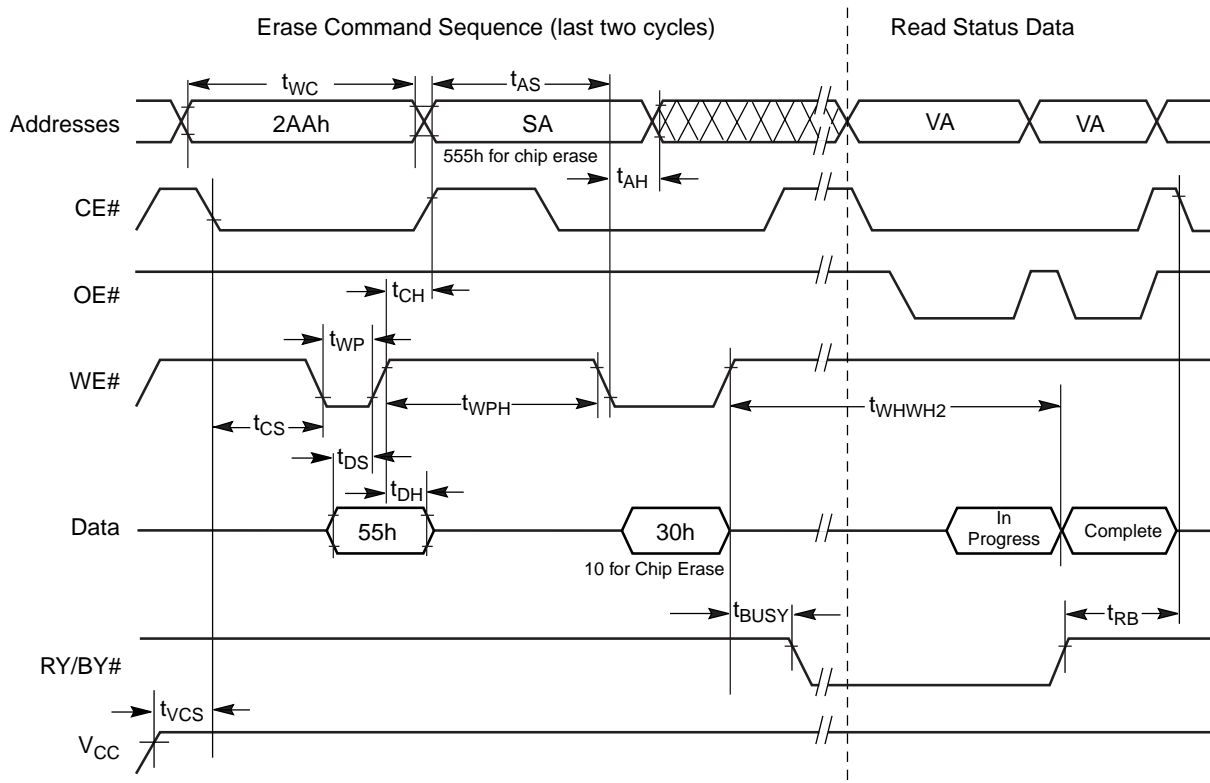

Figure 19. Accelerated Program Timing Diagram

AC CHARACTERISTICS



Notes:

1. SA = sector address (for Sector Erase), VA = Valid Address for reading status data (see "Write Operation Status").
2. These waveforms are for the word mode.

Figure 20. Chip/Sector Erase Operation Timings

AC CHARACTERISTICS

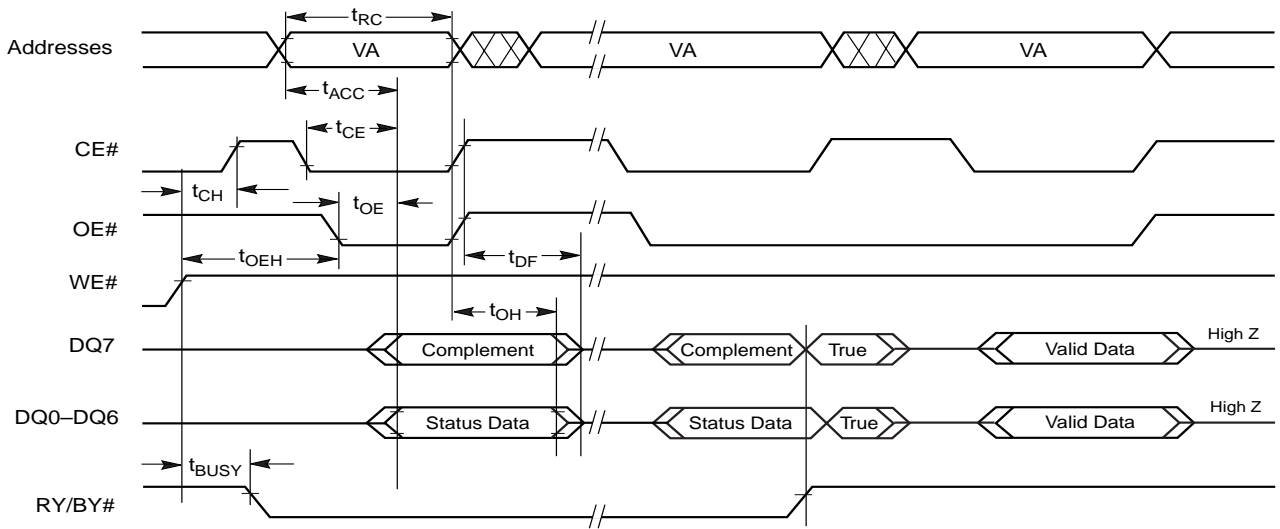

Note: VA = Valid address. Illustration shows first status cycle after command sequence, last status read cycle, and array data read cycle.

Figure 21. Data# Polling Timings (During Embedded Algorithms)

AC CHARACTERISTICS

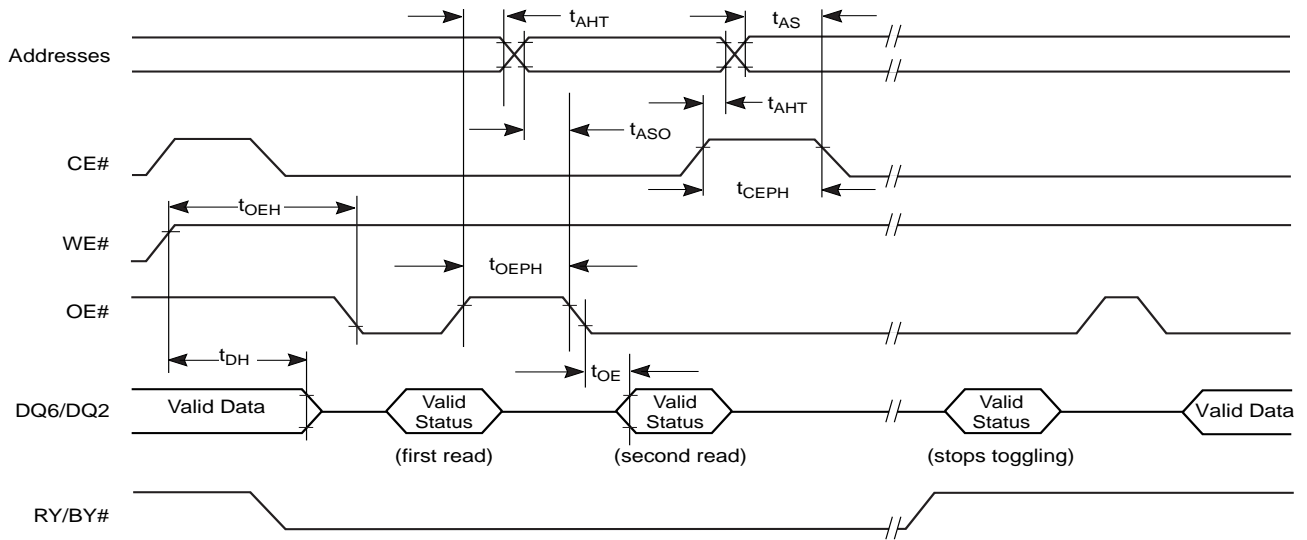

Note: VA = Valid address; not required for DQ6. Illustration shows first two status cycle after command sequence, last status read cycle, and array data read cycle

Figure 22. Toggle Bit Timings (During Embedded Algorithms)

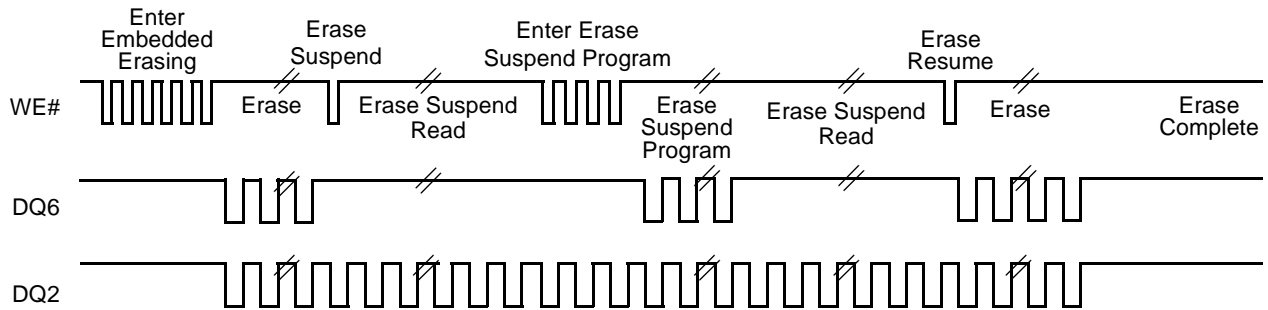

Note: DQ2 toggles only when read at an address within an erase-suspended sector. The system may use OE# or CE# to toggle DQ2 and DQ6.

Figure 23. DQ2 vs. DQ6

AC CHARACTERISTICS

Temporary Sector Group Unprotect

Parameter		Description		All Speed Options	Unit
JEDEC	Std				
	t_{VIDR}	V_{ID} Rise and Fall Time (See Note)	Min	500	ns
	t_{RSP}	RESET# Setup Time for Temporary Sector Unprotect	Min	4	μ s

Note:

1. Not 100% tested.
2. AC Specifications listed are tested with $V_{IO} = V_{CC}$. Contact AMD for information on AC operation with $V_{IO} \neq V_{CC}$.

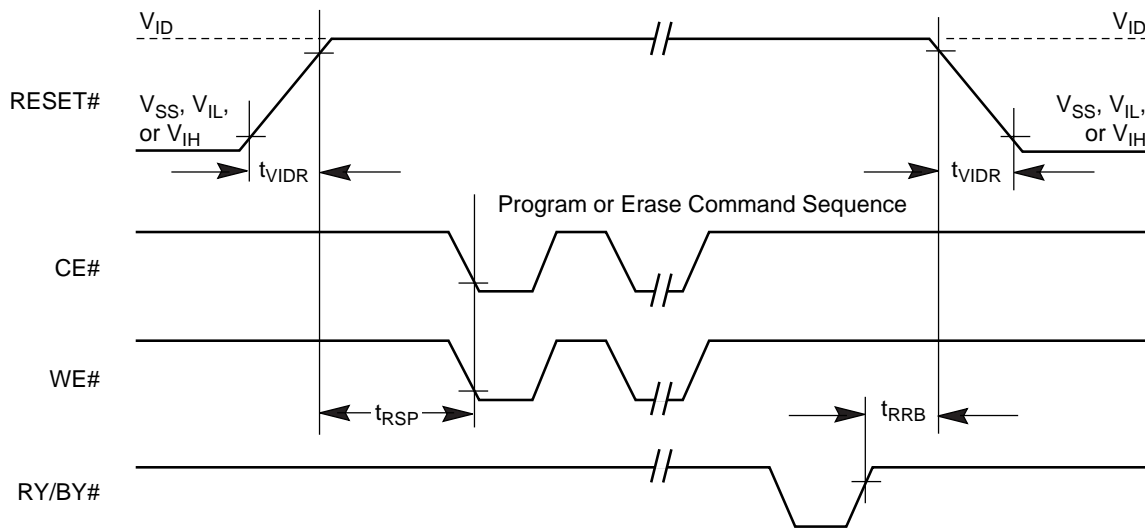
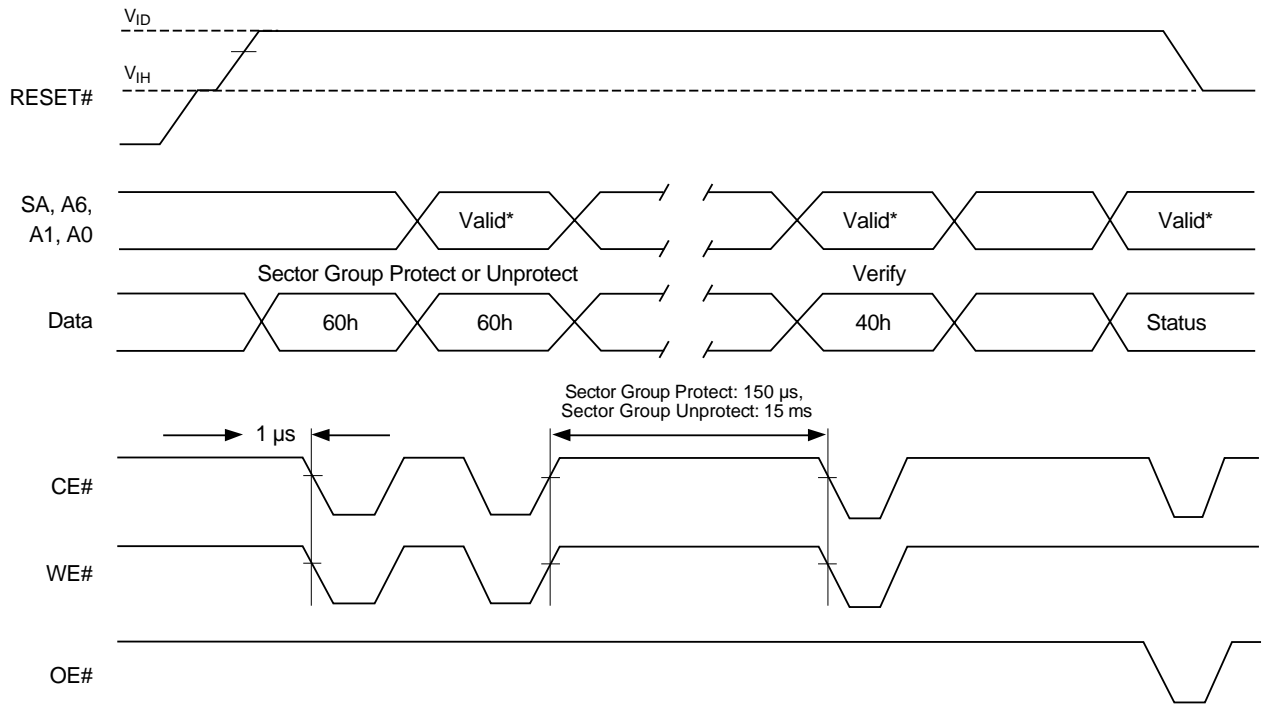

Figure 24. Temporary Sector Group Unprotect Timing Diagram

AC CHARACTERISTICS



* For sector group protect, A6 = 0, A1 = 1, A0 = 0. For sector group unprotect, A6 = 1, A1 = 1, A0 = 0.

Figure 25. Sector Group Protect and Unprotect Timing Diagram

AC CHARACTERISTICS

Alternate CE# Controlled Erase and Program Operations

Parameter		Description		Speed Options			Unit	
JEDEC	Std.			103, 103R	113, 113R	123, 123R		
t_{AVAV}	t_{WC}	Write Cycle Time (Note 1)	Min	100	110	120	ns	
t_{AVWL}	t_{AS}	Address Setup Time	Min	0			ns	
t_{ELAX}	t_{AH}	Address Hold Time	Min	45			ns	
t_{DVEH}	t_{DS}	Data Setup Time	Min	45			ns	
t_{EHDX}	t_{DH}	Data Hold Time	Min	0			ns	
t_{GHEL}	t_{GHEL}	Read Recovery Time Before Write (OE# High to WE# Low)	Min	0			ns	
t_{WLEL}	t_{WS}	WE# Setup Time	Min	0			ns	
t_{EHWH}	t_{WH}	WE# Hold Time	Min	0			ns	
t_{ELEH}	t_{CP}	CE# Pulse Width	Min	45			ns	
t_{EHEL}	t_{CPH}	CE# Pulse Width High	Min	30			ns	
t_{WHWH1}	t_{WHWH1}	Write Buffer Program Operation (Notes 2, 3)	Typ	240			μ s	
		Effective Write Buffer Program Operation (Notes 2, 4)	Per Byte	Typ	7.5			μ s
			Per Word	Typ	15			μ s
		Accelerated Effective Write Buffer Program Operation (Notes 2, 4)	Per Byte	Typ	5.9			μ s
			Per Word	Typ	11.8			μ s
		Single Byte Word Program Operation (Note 2, 5)	Byte	Typ	60			μ s
			Word	Typ	60			μ s
		Accelerated Single Byte Word Programming Operation (Note 2, 5)	Byte	Typ	54			μ s
Word	Typ		54			μ s		
t_{WHWH2}	t_{WHWH2}	Sector Erase Operation (Note 2)	Typ	0.5			sec	

Notes:

1. Not 100% tested.
2. See the "Erase And Programming Performance" section for more information.
3. For 1–16 words/1–32 bytes programmed.
4. Effective write buffer specification is based upon a 16-word/32-byte write buffer operation.
5. Byte/Word programming specification is based upon a single word/byte programming operation not utilizing the write buffer.
6. AC Specifications listed are tested with $V_{IO} = V_{CC}$. Contact AMD for information on AC operation with $V_{IO} \neq V_{CC}$.

AC CHARACTERISTICS

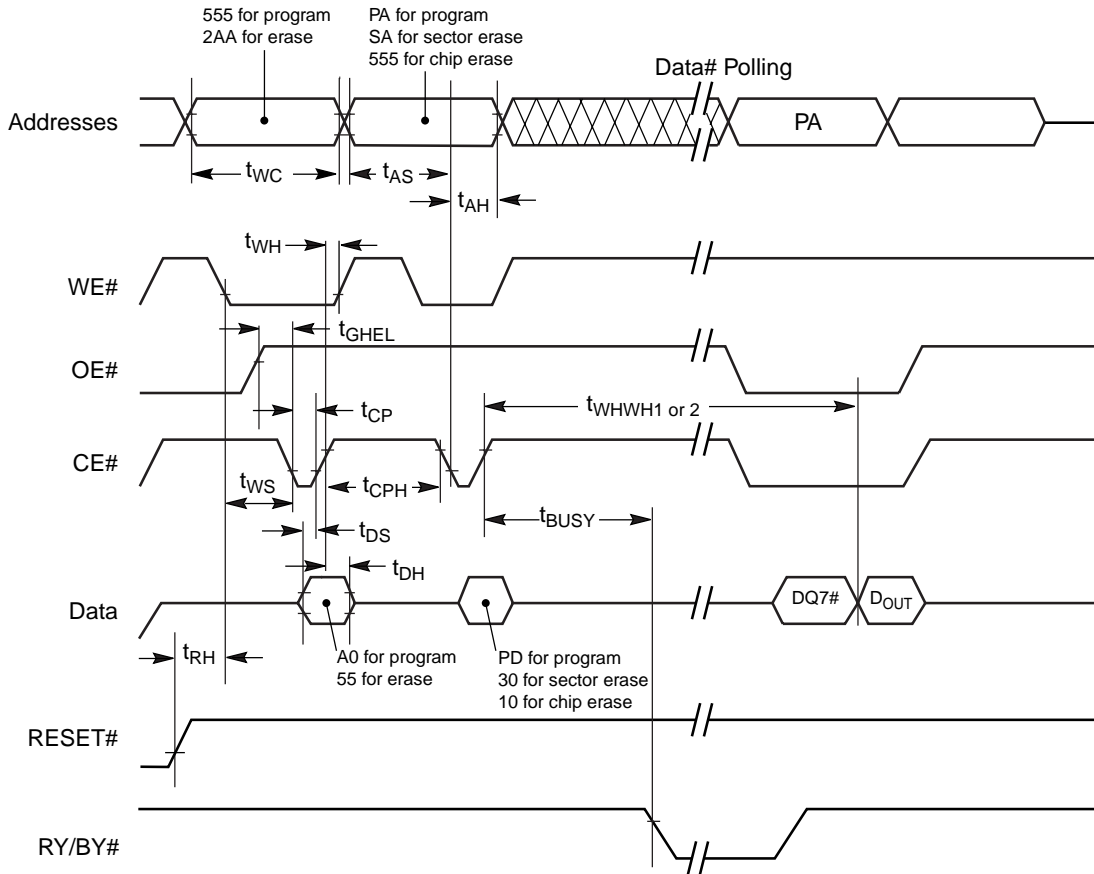

Notes:

1. Figure indicates last two bus cycles of a program or erase operation.
2. PA = program address, SA = sector address, PD = program data.
3. DQ7# is the complement of the data written to the device. D_{OUT} is the data written to the device.
4. Waveforms are for the word mode.

Figure 26. Alternate CE# Controlled Write (Erase/Program) Operation Timings

LATCHUP CHARACTERISTICS

Description	Min	Max
Input voltage with respect to V _{SS} on all pins except I/O pins (including A9, OE#, and RESET#)	-1.0 V	12.5 V
Input voltage with respect to V _{SS} on all I/O pins	-1.0 V	V _{CC} + 1.0 V
V _{CC} Current	-100 mA	+100 mA

Note: Includes all pins except V_{CC}. Test conditions: V_{CC} = 3.0 V, one pin at a time.

ERASE AND PROGRAMMING PERFORMANCE

Parameter		Typ (Note 1)	Max (Note 2)	Unit	Comments
Sector Erase Time		0.5	15	sec	Excludes 00h programming prior to erasure (Note 6)
Chip Erase Time		128	TBD	sec	
Effective Write Buffer Program Time (Note 3)	Per Byte	7.5	TBD	µs	Excludes system level overhead (Note 7)
	Per Word	15	TBD	µs	
Effective Accelerated Write Buffer Program Time (Note 3)	Per Byte	5.9	TBD	µs	
	Per Word	11.8	TBD	µs	
Single Byte/Word Program Time (Note 4)	Byte	60	TBD	µs	
	Word	60	TBD	µs	
Accelerated Single Byte/Word Program Time (Note 4)	Byte	54	TBD	µs	
	Word	54	TBD	µs	
Chip Program Time (Note 5)		126	TBD	sec	

Notes:

1. Typical program and erase times assume the following conditions: 25°C, 3.0 V V_{CC} , 100,000 cycles. Additionally, programming typicals assume checkerboard pattern.
2. Under worst case conditions of 90°C, $V_{CC} = 3.0$ V, 100,000 cycles.
3. Effective write buffer specification is based upon a 16-word/32-byte write buffer operation.
4. Byte/Word programming specification is based upon a single word/byte programming operation not utilizing the write buffer.
5. The typical chip programming time is considerably less than the maximum chip programming time listed, since most words program faster than the maximum program times listed.
6. In the pre-programming step of the Embedded Erase algorithm, all bits are programmed to 00h before erasure.
7. System-level overhead is the time required to execute the two- or four-bus-cycle sequence for the program command. See Table 11 for further information on command definitions.
8. The device has a minimum erase and program cycle endurance of 100,000 cycles.

TSOP PIN AND BGA PACKAGE CAPACITANCE

Parameter Symbol	Parameter Description	Test Setup	Typ	Max	Unit	
C_{IN}	Input Capacitance	$V_{IN} = 0$	TSOP	6	7.5	pF
			BGA	4.2	5	pF
C_{OUT}	Output Capacitance	$V_{OUT} = 0$	TSOP	8.5	12	pF
			BGA	5.4	6.5	pF
C_{IN2}	Control Pin Capacitance	$V_{IN} = 0$	TSOP	7.5	9	pF
			BGA	3.9	4.7	pF

Notes:

1. Sampled, not 100% tested.
2. Test conditions $T_A = 25^\circ\text{C}$, $f = 1.0$ MHz.

DATA RETENTION

Parameter Description	Test Conditions	Min	Unit
Minimum Pattern Data Retention Time	150°C	10	Years
	125°C	20	Years

PHYSICAL DIMENSIONS

TS056/TSR056—56-Pin Standard/Reverse Thin Small Outline Package (TSOP)

STANDARD PIN OUT (TOP VIEW)

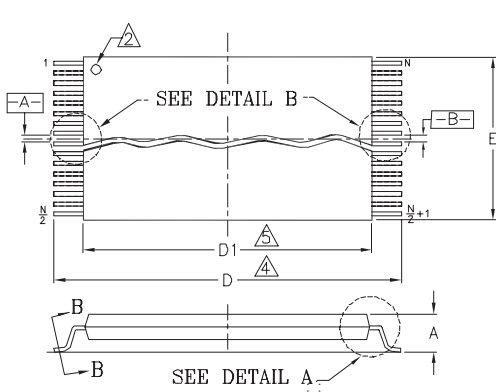

REVERSE PIN OUT (TOP VIEW)

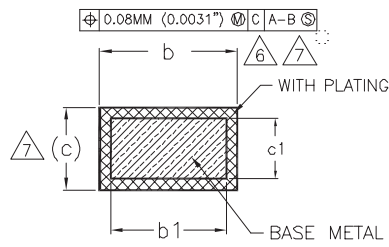
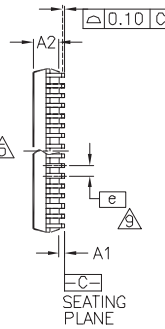
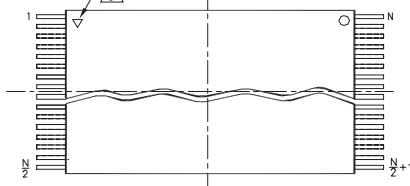

SECTION B-B

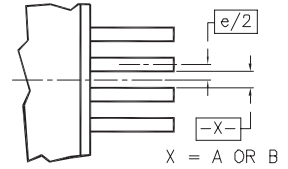

DETAIL B

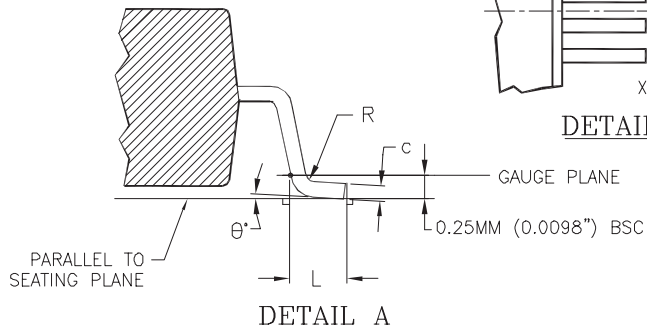

DETAIL A

PACKAGE	TS/TSR 56		
JEDEC	MO-142 (B) EC		
SYMBOL	MIN.	NOM.	MAX.
A	---	---	1.20
A1	0.05	---	0.15
A2	0.95	1.00	1.05
b1	0.17	0.20	0.23
b	0.17	0.22	0.27
c1	0.10	---	0.16
c	0.10	---	0.21
D	19.90	20.00	20.20
D1	18.30	18.40	18.50
E	13.90	14.00	14.10
e	0.50 BASIC		
L	0.50	0.60	0.70
∅	0°	3°	5°
R	0.08	---	0.20
N	56		

NOTES:

- 1 CONTROLLING DIMENSIONS ARE IN MILLIMETERS (mm). (DIMENSIONING AND TOLERANCING CONFORMS TO ANSI Y14.5M-1982.)
- 2 PIN 1 IDENTIFIER FOR STANDARD PIN OUT (DIE UP).
- 3 PIN 1 IDENTIFIER FOR REVERSE PIN OUT (DIE DOWN), INK OR LASER MARK.
- 4 TO BE DETERMINED AT THE SEATING PLANE [C-]. THE SEATING PLANE IS DEFINED AS THE PLANE OF CONTACT THAT IS MADE WHEN THE PACKAGE LEADS ARE ALLOWED TO REST FREELY ON A FLAT HORIZONTAL SURFACE.
- 5 DIMENSIONS D1 AND E DO NOT INCLUDE MOLD PROTRUSION. ALLOWABLE MOLD PROTRUSION IS 0.15 mm PER SIDE.
- 6 DIMENSION b DOES NOT INCLUDE DAMBAR PROTUSION. ALLOWABLE DAMBAR PROTUSION SHALL BE 0.08 mm TOTAL IN EXCESS OF b DIMENSION AT MAX MATERIAL CONDITION. MINIMUM SPACE BETWEEN PROTRUSION AND AN ADJACENT LEAD TO BE 0.07 mm.
- 7 THESE DIMENSIONS APPLY TO THE FLAT SECTION OF THE LEAD BETWEEN 0.10 mm AND 0.25 mm FROM THE LEAD TIP.
8. LEAD COPLANARITY SHALL BE WITHIN 0.10 mm AS MEASURED FROM THE SEATING PLANE.
- 9 DIMENSION "e" IS MEASURED AT THE CENTERLINE OF THE LEADS.

316038.10A

PHYSICAL DIMENSIONS

LAA064—64-Ball Fortified Ball Grid Array
13 x 11 mm Package

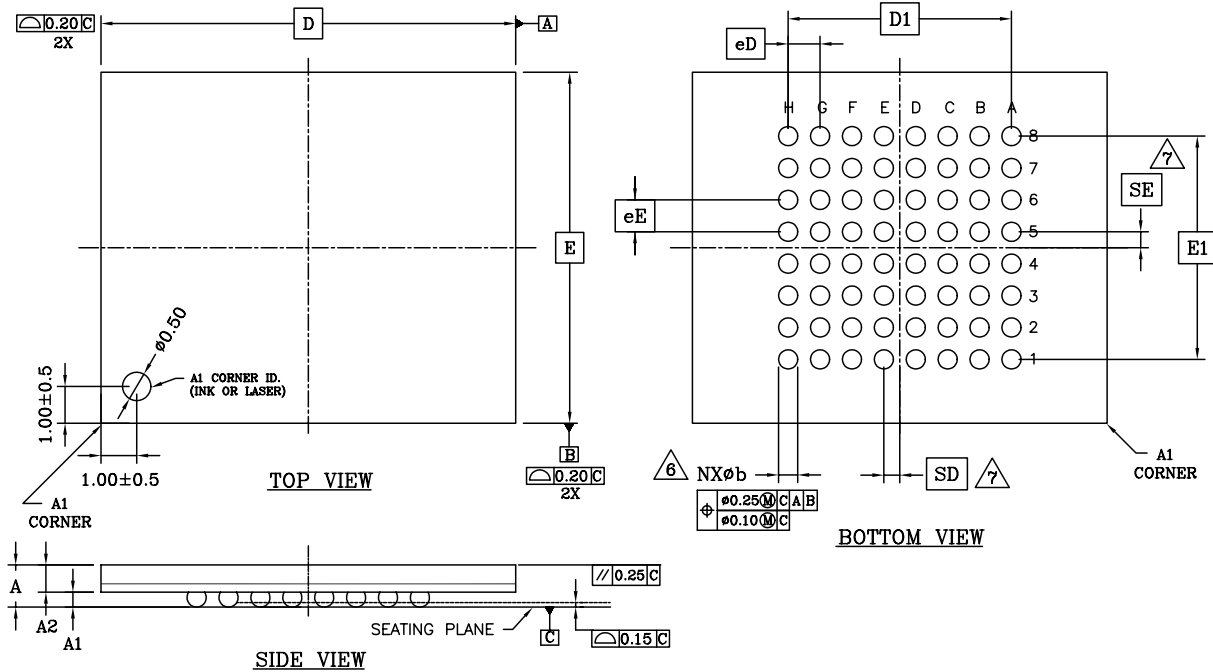

PACKAGE	LAA 064			
JEDEC	N/A			
	13.00x11.00 mm PACKAGE			
SYMBOL	MIN.	NOM.	MAX.	NOTE
A	-	-	1.40	PROFILE HEIGHT
A1	0.40	-	-	STANDOFF
A2	0.60	-	-	BODY THICKNESS
D	13.00 BSC.			BODY SIZE
E	11.00 BSC.			BODY SIZE
D1	7.00 BSC.			MATRIX FOOTPRINT
E1	7.00 BSC.			MATRIX FOOTPRINT
MD	8			MATRIX SIZE D DIRECTION
ME	8			MATRIX SIZE E DIRECTION
N	64			BALL COUNT
øb	0.50	0.60	0.70	BALL DIAMETER
eD	1.00 BSC.			BALL PITCH - D DIRECTION
eE	1.00 BSC.			BALL PITCH - E DIRECTION
SD/SE	0.50 BSC.			SOLDER BALL PLACEMENT
	A1-AB, K1-K8			DEPOPULATED SOLDER BALLS

NOTES:

- DIMENSIONING AND TOLERANCING METHODS PER ASME Y14.5M-1994 .
- ALL DIMENSIONS ARE IN MILLIMETERS .
- BALL POSITION DESIGNATION PER JESD 95-1, SPP-010 (EXCEPT AS NOTED).
- [e] REPRESENTS THE SOLDER BALL GRID PITCH .
- SYMBOL "MD" IS THE BALL MATRIX SIZE IN THE "D" DIRECTION.
SYMBOL "ME" IS THE BALL COLUMN MATRIX SIZE IN THE "E" DIRECTION.
N IS THE NUMBER OF POPULATED SOLDER BALL POSITIONS FOR MATRIX SIZE MD X ME.
- 6 DIMENSION "b" IS MEASURED AT THE MAXIMUM BALL DIAMETER IN A PLANE PARALLEL TO DATUM "C".
- 7 SD AND SE ARE MEASURED WITH RESPECT TO DATUMS A AND B AND DEFINE THE POSITION OF THE CENTER SOLDER BALL IN THE OUTER ROW.
WHEN THERE IS AN ODD NUMBER OF SOLDER BALLS IN THE OUTER ROW, SD OR SE = 0.000.
WHEN THERE IS AN EVEN NUMBER OF SOLDER BALLS IN THE OUTER ROW, SD OR SE = $\frac{e}{2}$
- "X" IN THE PACKAGE VARIATIONS DENOTES PART IS UNDER QUALIFICATION.
- "+" INDICATES THE THEORETICAL CENTER OF DEPOPULATED BALLS.

REVISION SUMMARY**Revision A (October 3, 2001)**

Initial release as abbreviated Advance Information data sheet.

Revision A+1 (March 20, 2002)**Distinctive Characteristics**

Clarified description of Enhanced VersatileIO control.

Ordering Information

Corrected device density in device number/description.

Physical Dimensions

Added drawing that shows both TS056 and TSR056 specifications.

Revision B (July 1, 2002)

Expanded data sheet to full specification version.

Revision B+1 (September 16, 2002)**Distinctive Characteristics, Physical Dimensions**

Added 80-Ball Fine-Pitch BGA.

Product Selector Guide

Added 80-Ball Fine-Pitch BGA.

Added Note #1.

Added 103, 108, 113, 118, 123, 128 regulated OPNs.

Changed all OPNs that end with 4 or 9 to 3 or 8.

Program Suspend/Program Resume Command Sequence

Changed 1ms to 15 μ s maximum, with a typical of 5 μ s.

Erase Suspend/Erase Resume Commands

Added that the device requires a typical of 5 μ s.

Read-Only Operations, Erase Program Operations, and Alternate CE# Controlled Erase and Program Operations

Added regulated OPNs.

Changed all OPNs that end with 4 or 9 to 3 or 8.

Revision B+2 (November 11, 2002)**Global**

Removed the Enhanced VI/O option and changed it to VI/O only.

Distinctive Characteristics

Changed the typical sector erase time to TBD.

Changed the typical write buffer word programming time to TBD.

Product Selector Guide

Removed the 98R, 108, 108R, 118, 118R, 128, and 128R Speed Options.

Replaced Note #2.

Product Selector Guide and Read Only Operations

Added a 30 ns Page Access time and Output Enable Access time to the 113R and 123R Speed Options.

Ordering Information

Modified Order numbers and package markings to reflect the removal of speed options.

Modified the V_{IO} ranges.

Added Notes #1 and #2.

Table 4. SecSi Sector Contents

Added x8 and x16

Operating Ranges

Changed the V_{IO} supply range to 1.65–3.6 V.

Added V_{IO} (regulated voltage range) and V_{IO} (full voltage range).

CMOS Compatible

Removed V_{IL} , V_{IH} , V_{OL} , and V_{OH} from table and added V_{IL1} , V_{IH1} , V_{IL2} , V_{IH2} , V_{OL} , V_{OH1} , and V_{OH2} from the CMOS table in the Am29LV640MH/L datasheet.

Erase and Programming Performance

Changed the typicals and/or maximums of Chip Erase Time, Sector Erase Time, Effective Write Buffer Program Time, Program Time, and Accelerated Program Time to TBD.

Customer Lockable: SecSi Sector NOT Programmed or Protected at the factory.

Added second bullet, SecSi sector-protect verify text and figure 3.

SecSi Sector Flash Memory Region, and Enter SecSi Sector/Exit SecSi Sector Command Sequence

Noted that the ACC function and unlock bypass modes are not available when the SecSi sector is enabled.

Byte/Word Program Command Sequence, Sector Erase Command Sequence, and Chip Erase Command Sequence

Noted that the SecSi Sector, autoselect, and CFI functions are unavailable when a program or erase operation is in progress.

Common Flash Memory Interface (CFI)

Changed wording in last sentence of third paragraph from, "...the autoselect mode." to "...reading array data."

Changed CFI website address

Revision B+3 (December 2, 2002)**Global**

Added sector group protection throughout datasheet and added Table 4.

Product Selector Guide

Added V_{IO} s to table and removed Note #2

Ordering Information

Corrected typos in V_{IO} ranges.

Removed Notes #1 and 2.

Figure 6. Program Suspend/Program Resume

Change wait time to 15 μ s.

Operating Ranges

Corrected typos in V_{IO} ranges.

Removed full voltage range.

CMOS Compatible

Changed V_{IH1} and V_{IH2} minimum to 1.9.

Removed typos in notes.

Read-Only Characteristics

Added a 30 ns option to t_{PACC} and t_{OE} standard in table.

Added note #3.

Hardware Reset, Erase and Program Operations, Temporary Sector Unprotect, and Alternate CE# Controlled Erase and Program Operations

Added Note.

Revision B+4 (February 14, 2003)**Distinctive Characteristics**

Corrected performance characteristics.

Product Selector Guide

Removed 93R speed option.

Added note 2.

Ordering Information

Corrected Valid Combination to reflect speed option changes.

Added Note.

AC Characteristics

Removed 93, 93R speed option.

Added Note

Input values in the t_{WHWH1} and t_{WHWH2} parameters in the Erase and Program Options table that were previously TBD. Also added notes 5 and 6.

Input values in the t_{WHWH1} and t_{WHWH2} parameters in the Alternate CE# Controlled Erase and Program Options table that were previously TBD. Also added notes 5.

Erase and Programming Performance

Input values into table that were previously TBD.

Added note 4.

Trademarks

Copyright © 2002 Advanced Micro Devices, Inc. All rights reserved.

AMD, the AMD logo, and combinations thereof are registered trademarks of Advanced Micro Devices, Inc.

ExpressFlash is a trademark of Advanced Micro Devices, Inc.

Product names used in this publication are for identification purposes only and may be trademarks of their respective companies.

Sales Offices and Representatives

North America

ALABAMA	(256)830-9192
ARIZONA	(602)242-4400
CALIFORNIA,	
Irvine	(949)450-7500
Sunnyvale	(408)732-2400
COLORADO	(303)741-2900
CONNECTICUT	(203)264-7800
FLORIDA,	
Clearwater	(727)793-0055
Miami (Lakes)	(305)820-1113
GEORGIA	(770)814-0224
ILLINOIS,	
Chicago	(630)773-4422
MASSACHUSETTS	(781)213-6400
MICHIGAN	(248)471-6294
MINNESOTA	(612)745-0005
NEW JERSEY,	
Chatham	(973)701-1777
NEW YORK	(716)425-8050
NORTH CAROLINA	(919)840-8080
OREGON	(503)245-0080
PENNSYLVANIA	(215)340-1187
SOUTH DAKOTA	(605)692-5777
TEXAS,	
Austin	(512)346-7830
Dallas	(972)985-1344
Houston	(281)376-8084
VIRGINIA	(703)736-9568

International

AUSTRALIA, North Ryde	TEL(61)2-88-777-222
BELGIUM, Antwerpen	TEL(32)3-248-43-00
BRAZIL, San Paulo	TEL(55)11-5501-2105
CHINA,	
Beijing	TEL(86)10-6510-2188
Shanghai	TEL(86)21-635-00838
Shenzhen	TEL(86)755-246-1550
FINLAND, Helsinki	TEL(358)881-3117
FRANCE, Paris	TEL(33)-1-49751010
GERMANY,	
Bad Homburg	TEL(49)-6172-92670
Munich	TEL(49)-89-450530
HONG KONG, Causeway Bay	TEL(852)-2956-0388
ITALY, Milan	TEL(39)-02-381961
INDIA, New Delhi	TEL(91)11-623-8620
JAPAN,	
Osaka	TEL(81)6-6243-3250
Tokyo	TEL(81)3-3346-7600
KOREA, Seoul	TEL(82)2-3468-2600
RUSSIA, Moscow	TEL(7)-095-795-06-22
SWEDEN, Stockholm	TEL(46)8-562-540-00
TAIWAN, Taipei	TEL(886)2-8773-1555
UNITED KINGDOM,	
Frimley	TEL(44)1276-803100
Haydock	TEL(44)1942-272888

Advanced Micro Devices reserves the right to make changes in its product without notice in order to improve design or performance characteristics. The performance characteristics listed in this document are guaranteed by specific tests, guard banding, design and other practices common to the industry. For specific testing details, contact your local AMD sales representative. The company assumes no responsibility for the use of any circuits described herein.

© Advanced Micro Devices, Inc. All rights reserved.
AMD, the AMD Arrow logo and combination thereof, are trademarks of Advanced Micro Devices, Inc. Other product names are for informational purposes only and may be trademarks of their respective companies.

Representatives in U.S. and Canada

ARIZONA,	
Tempe - Centaur	(480)839-2320
CALIFORNIA,	
Calabasas - Centaur	(818)878-5800
Irvine - Centaur	(949)261-2123
San Diego - Centaur	(858)278-4950
Santa Clara - Fourfront	(408)350-4800
CANADA,	
Burnaby, B.C. - Davetek Marketing	(604)430-3680
Calgary, Alberta - Davetek Marketing	(403)283-3577
Kanata, Ontario - J-Squared Tech	(613)592-9540
Mississauga, Ontario - J-Squared Tech	(905)672-2030
St. Laurent, Quebec - J-Squared Tech	(514)747-1211
COLORADO,	
Golden - Compass Marketing	(303)277-0456
FLORIDA,	
Melbourne - Marathon Technical Sales	(321)728-7706
Ft. Lauderdale - Marathon Technical Sales	(954)527-4949
Orlando - Marathon Technical Sales	(407)872-5775
St. Petersburg - Marathon Technical Sales	(727)894-3603
GEORGIA,	
Duluth - Quantum Marketing	(678)584-1128
ILLINOIS,	
Skokie - Industrial Reps, Inc.	(847)967-8430
INDIANA,	
Kokomo - SAI	(765)457-7241
IOWA,	
Cedar Rapids - Lorenz Sales	(319)294-1000
KANSAS,	
Lenexa - Lorenz Sales	(913)469-1312
MASSACHUSETTS,	
Burlington - Synergy Associates	(781)238-0870
MICHIGAN,	
Brighton - SAI	(810)227-0007
MINNESOTA,	
St. Paul - Cahill, Schmitz & Cahill, Inc.	(651)699-0200
MISSOURI,	
St. Louis - Lorenz Sales	(314)997-4558
NEW JERSEY,	
Mt. Laurel - SJ Associates	(856)866-1234
NEW YORK,	
Buffalo - Nycom, Inc.	(716)741-7116
East Syracuse - Nycom, Inc.	(315)437-8343
Pittsford - Nycom, Inc.	(716)586-3660
Rockville Centre - SJ Associates	(516)536-4242
NORTH CAROLINA,	
Raleigh - Quantum Marketing	(919)846-5728
OHIO,	
Middleburg Hts - Dolfuss Root & Co.	(440)816-1660
Powell - Dolfuss Root & Co.	(614)781-0725
Vandalia - Dolfuss Root & Co.	(937)898-9610
Westerville - Dolfuss Root & Co.	(614)523-1990
OREGON,	
Lake Oswego - I Squared, Inc.	(503)670-0557
UTAH,	
Murray - Front Range Marketing	(801)288-2500
VIRGINIA,	
Glen Burnie - Coherent Solution, Inc.	(410)761-2255
WASHINGTON,	
Kirkland - I Squared, Inc.	(425)822-9220
WISCONSIN,	
Pewaukee - Industrial Representatives	(262)574-9393

Representatives in Latin America

ARGENTINA,	
Capital Federal Argentina/WW Rep.	(54-11)4373-0655
CHILE,	
Santiago - LatinRep/WW Rep.	(+562)264-0993
COLUMBIA,	
Bogota - Dimser	(571)410-4182
MEXICO,	
Guadalajara - LatinRep/WW Rep.	(523)817-3900
Mexico City - LatinRep/WW Rep.	(525)752-2727
Monterrey - LatinRep/WW Rep.	(528)369-6828
PUERTO RICO,	
Boqueron - Inftronics	(787)851-6000



One AMD Place, P.O. Box 3453, Sunnyvale, CA 94088-3453 408-732-2400
TWX 910-339-9280 TELEX 34-6306 800-538-8450 <http://www.amd.com>

©2003 Advanced Micro Devices, Inc.
01/03
Printed in USA

