

Solid Tantalum Chip Capacitors TANTAMOUNT® Conformal Coated

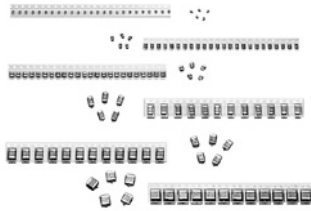

FEATURES

- 8 mm, 12 mm Tape Packaging to EIA-481-1 reeling per IEC 286-3. 7" (178 mm) standard 13" (330 mm) available
- US and European case sizes available



PERFORMANCE CHARACTERISTICS

Operating Temperature: - 55°C to + 85°C.
(To + 125°C with voltage derating.)

Capacitance Range: 0.1 µF to 330 µF

Capacitance Tolerance: ± 10 %, ± 20 % standard.

Voltage Rating: 2 WVDC to 50 WVDC

ORDERING INFORMATION

195D TYPE	106 CAPACITANCE	X0 CAPACITANCE TOLERANCE	004 DC VOLTAGE RATING AT + 85 °C	S CASE CODE	2 TERMINATION	T PACKAGING
This is expressed in picofarads. The first two digits are the significant figures. The third is the number of zeros to follow.	X0 = ± 20 % X9 = ± 10 %	This is expressed in volts. To complete the three-digit block, zeros precede the voltage rating. A decimal point is indicated by an "R" (6R3 = 6.3 volts).	See Ratings and Case Codes Table.	Style 2 is standard 2 = 100 % Tin 4 = Gold Plated 8 = Solder Plated (60/40) Special Order	T = Tape and Reel 7" [178 mm] Reel standard 1/2" Reel minimum 13" [330] Reel available excluding the "R" case, on request. See Tape and Reel Specifications.	

Note: Preferred Tolerance and reel sizes are in bold. We reserve the right to supply higher voltage ratings and tighter capacitance tolerance capacitors in the same case size. Voltage substitutions will be marked with the higher voltage rating.

DIMENSIONS in inches [millimeters]

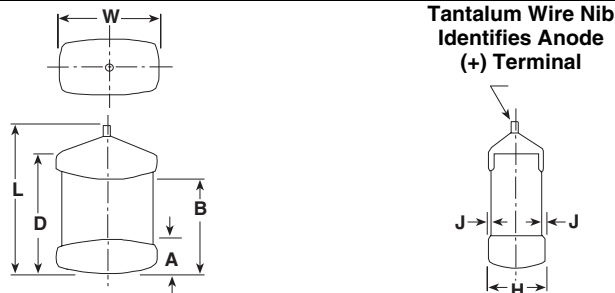

CASE CODE	EIA SIZE	L (Max.)	W	H	A	B	D (Ref.)	J (Max.)
C	N / A	0.087 [2.21]	0.045 ± 0.010 [1.14 ± 0.25]	0.045 ± 0.010 [1.14 ± 0.25]	0.016 ± 0.008 [0.40 ± 0.20]	0.042 ± 0.010 [1.07 ± 0.25]	0.063 [1.60]	0.004 [0.10]
R	7257	0.283 [7.2]	0.235 ± 0.013 [6.0 ± 0.3]	0.136 ± 0.010 [3.15 ± 0.3]	0.051 ± 0.013 [1.3 ± 0.3]	0.180 ± 0.025 [4.6 ± 0.6]	0.243 [6.20]	0.004 [0.10]
S	3518	0.143 [3.63]	0.072 ± 0.008 [1.83 ± 0.20]	0.048 ± 0.008 [1.22 ± 0.20]	0.023 ± 0.010 [0.58 ± 0.25]	0.085 ± 0.015 [2.16 ± 0.37]	0.115 [2.90]	0.004 [0.10]
V	3527	0.143 [3.63]	0.104 ± 0.010 [2.65 ± 0.25]	0.051 ± 0.010 [1.30 ± 0.25]	0.023 ± 0.010 [0.58 ± 0.25]	0.085 ± 0.015 [2.16 ± 0.37]	0.115 [2.90]	0.004 [0.10]
X	7227	0.285 [7.24]	0.104 ± 0.010 [2.65 ± 0.25]	0.051 ± 0.010 [1.30 ± 0.25]	0.040 ± 0.020 [1.00 ± 0.50]	0.200 ± 0.027 [5.08 ± 0.69]	0.243 [6.20]	0.004 [0.10]
Y	7227	0.285 [7.24]	0.104 ± 0.010 [2.65 ± 0.25]	0.069 ± 0.010 [1.75 ± 0.25]	0.040 ± 0.020 [1.00 ± 0.50]	0.200 ± 0.027 [5.08 ± 0.69]	0.243 [6.20]	0.004 [0.10]
Z	7227	0.285 [7.24]	0.104 ± 0.010 [2.65 ± 0.25]	0.104 ± 0.010 [2.65 ± 0.25]	0.040 ± 0.020 [1.00 ± 0.50]	0.200 ± 0.023 [5.08 ± 0.59]	0.243 [6.20]	0.004 [0.10]

Note: The anode termination (D less B) will be a minimum of 0.010 (0.25), C Case = 0.005 (0.131) minimum



Solid Tantalum Chip Capacitors
TANTAMOUNT® Conformal Coated

RATINGS AND CASE CODES								
µF	4 V	6.3 V	10 V	16 V	20 V	25 V	35 V	50 V
0.10								C
0.15								C
0.22								C
0.33							C	S
0.47						C	S	V
0.68					C	S	S	V
1.0				C	S	S	S	X
1.5			C	S	S	S	V	X
2.2		C	S	S	S	V	X	Y
3.3	C	S	S	S	V	X	Y	Z
4.7	S	S	S	V	X	X	Z	Z
6.8	S	S	V	X	X	Y	Z	R
10	S	V	X	X	Y	Y	Z	R
15	V	X	X	Y	Z	Z	R	
22	X	X	Y	Z	Z	R	R	
33	X	Y	Z	Z	R	R		
47	Y	Y	Z	R	R			
68	Y	Z	R	R				
100	Z	Z	R					
120	R	R	R					
150	R	R	R					
180	R	R						
220	R	R						
330	R							

STANDARD RATINGS					
CAPACITANCE (µF)	CASE CODE	PART NUMBER*	Max. DCL at + 25 °C (µA)	Max. DF at + 25 °C 120 Hz (%)	
4 WVDC @ + 85 °C, SURGE = 5 V . . . 2.7 WVDC @ + 125 °C, SURGE = 3.4 V					
3.3	C	195D335X_004C2T	0.5	6	
4.7	S	195D475X_004S2T	0.5	6	
6.8	S	195D685X_004S2T	0.5	6	
10	S	195D106X_004S2T	0.5	6	
15	V	195D156X_004V2T	0.6	6	
22	X	195D226X_004X2T	0.9	6	
33	X	195D336X_004X2T	1.3	6	
47	Y	195D476X_004Y2T	1.9	6	
68	Y	195D686X_004Y2T	2.7	6	
100	Z	195D107X_004Z2T	4.0	8	
120	R	195D127X_004R2T	4.8	8	
150	R	195D157X_004R2T	6.0	8	
180	R	195D187X_004R2T	7.2	8	
220	R	195D227X_004R2T	8.8	8	
330	R	195D337X_004R2T	13.2	8	

For 10 % tolerance, specify "9"; for 20 % tolerance, change to "0".

STANDARD RATINGS				
CAPACITANCE (μF)	CASE CODE	PART NUMBER*	Max. DCL at + 25 °C (μA)	Max. DF at + 25 °C 120 Hz (%)
6.3 WVDC @ + 85 °C, SURGE = 8 V . . . 4 WVDC @ + 125 °C, SURGE = 5 V				
2.2	C	195D225X_6R3C2T	0.5	6
3.3	S	195D335X_6R3S2T	0.5	6
4.7	S	195D475X_6R3S2T	0.5	6
6.8	S	195D685X_6R3S2T	0.5	6
10	V	195D106X_6R3V2T	0.6	6
15	X	195D156X_6R3X2T	0.9	6
22	X	195D226X_6R3X2T	1.3	6
33	Y	195D336X_6R3Y2T	2.0	6
47	Y	195D476X_6R3Y2T	2.8	6
68	Z	195D686X_6R3Z2T	4.1	6
100	Z	195D107X_6R3Z2T	6.0	8
120	R	195D127X_6R3R2T	7.2	8
150	R	195D157X_6R3R2T	9.0	8
180	R	195D187X_6R3R2T	10.8	8
220	R	195D227X_6R3R2T	13.2	8
10 WVDC @ + 85 °C, SURGE = 13V . . . 7 WVDC @ + 125 °C, SURGE = 9 V				
1.5	C	195D155X_010C2T	0.5	6
2.2	S	195D225X_010S2T	0.5	6
3.3	S	195D335X_010S2T	0.5	6
4.7	S	195D475X_010S2T	0.5	6
6.8	V	195D685X_010V2T	0.7	6
10	X	195D106X_010X2T	1.0	6
15	X	195D156X_010X2T	1.5	6
22	Y	195D226X_010Y2T	2.2	6
33	Z	195D336X_010Z2T	3.0	6
47	Z	195D476X_010Z2T	4.7	6
68	R	195D686X_010R2T	6.8	6
100	R	195D107X_010R2T	10	8
120	R	195D127X_010R2T	12	8
150	R	195D157X_010R2T	15	8
16 WVDC @ + 85 °C, SURGE = 20 V . . . 10 WVDC @ + 125 °C, SURGE = 12 V				
1.0	C	195D105X_016C2T	0.5	4
1.5	S	195D155X_016S2T	0.5	6
2.2	S	195D225X_016S2T	0.5	6
3.3	S	195D335X_016S2T	0.5	6
4.7	V	195D475X_016V2T	0.7	6
6.8	X	195D685X_016X2T	1.0	6
10	X	195D106X_016X2T	1.5	6
15	Y	195D156X_016Y2T	2.3	6
22	Z	195D226X_016Z2T	3.3	6
33	Z	195D336X_016Z2T	5.0	6
47	R	195D476X_016R2T	7.1	6
68	R	195D686X_016R2T	10.2	6

For 10 % tolerance, specify "9"; for 20 % tolerance, change to "0".



Solid Tantalum Chip Capacitors
TANTAMOUNT® Conformal Coated

195D
Vishay Sprague

STANDARD RATINGS				
CAPACITANCE (µF)	CASE CODE	PART NUMBER*	Max. DCL at + 25 °C (µA)	Max. DF at + 25 °C 120 Hz (%)
20 WVDC @ + 85 °C, SURGE = 26 V . . . 13 WVDC @ + 125 °C, SURGE = 16 V				
0.68	C	195D684X_020C2T	0.5	4
1.0	S	195D105X_020S2T	0.5	4
1.5	S	195D155X_020S2T	0.5	6
2.2	S	195D225X_020S2T	0.5	6
3.3	V	195D335X_020V2T	0.7	6
4.7	X	195D475X_020X2T	0.9	6
6.8	X	195D685X_020X2T	1.4	6
10	Y	195D106X_020Y2T	2.0	6
15	Z	195D156X_020Z2T	3.0	6
22	Z	195D226X_020Z2T	4.4	6
33	R	195D336X_020R2T	6.6	6
47	R	195D476X_020R2T	9.4	6
25 WVDC @ + 85 °C, SURGE = 32 V . . . 17 WVDC @ + 125 °C, SURGE = 20 V				
0.47	C	195D474X_025C2T	0.5	4
0.68	S	195D684X_025S2T	0.5	4
1.0	S	195D105X_025S2T	0.5	4
1.5	S	195D155X_025S2T	0.5	6
2.2	V	195D225X_025V2T	0.6	6
3.3	X	195D335X_025X2T	0.8	6
4.7	X	195D475X_025X2T	1.2	6
6.8	Y	195D685X_025Y2T	1.7	6
10	Y	195D106X_025Y2T	2.5	6
15	Z	195D156X_025Z2T	3.8	6
22	R	195D226X_025R2T	5.5	6
33	R	195D336X_025R2T	8.3	6
35 WVDC @ + 85 °C, SURGE = 46 V . . . 23 WVDC @ + 125 °C, SURGE = 28 V				
0.33	C	195D334X_035C2T	0.5	4
0.47	S	195D474X_035S2T	0.5	4
0.68	S	195D684X_035S2T	0.5	4
1.0	S	195D105X_035S2T	0.5	4
1.5	V	195D155X_035V2T	0.5	6
2.2	X	195D225X_035X2T	0.8	6
3.3	Y	195D335X_035Y2T	1.2	6
4.7	Z	195D475X_035Z2T	1.6	6
6.8	Z	195D685X_035Z2T	2.4	6
10	Z	195D106X_035Z2T	3.5	6
15	R	195D156X_035R2T	5.3	6
22	R	195D226X_035R2T	7.7	6

For 10 % tolerance, specify "9": for 20 % tolerance, change to "0".

Solid Tantalum Chip Capacitors
TANTAMOUNT® Conformal Coated

STANDARD RATINGS				
CAPACITANCE (μF)	CASE CODE	PART NUMBER*	Max. DCL at + 25 °C (μA)	Max. DF at + 25 °C 120 Hz (%)
50 WVDC @ + 85 °C, SURGE = 65 V . . . 33 WVDC @ + 125 °C, SURGE = 38 V				
0.1	C	195D104X_050C2T	0.5	4
0.15	C	195D154X_050C2T	0.5	4
0.22	C	195D224X_050C2T	0.5	4
0.33	S	195D334X_050S2T	0.5	4
0.47	V	195D474X_050V2T	0.5	4
0.68	V	195D684X_050V2T	0.5	4
1.0	X	195D105X_050X2T	0.5	4
1.5	X	195D155X_050X2T	0.8	6
2.2	Y	195D225X_050Y2T	1.1	6
3.3	Z	195D335X_050Z2T	1.7	6
4.7	Z	195D475X_050Z2T	2.4	6
6.8	R	195D685X_050R2T	3.4	6
10	R	195D106X_050R2T	5.0	6

For 10 % tolerance, specify "9": for 20 % tolerance, change to "0".

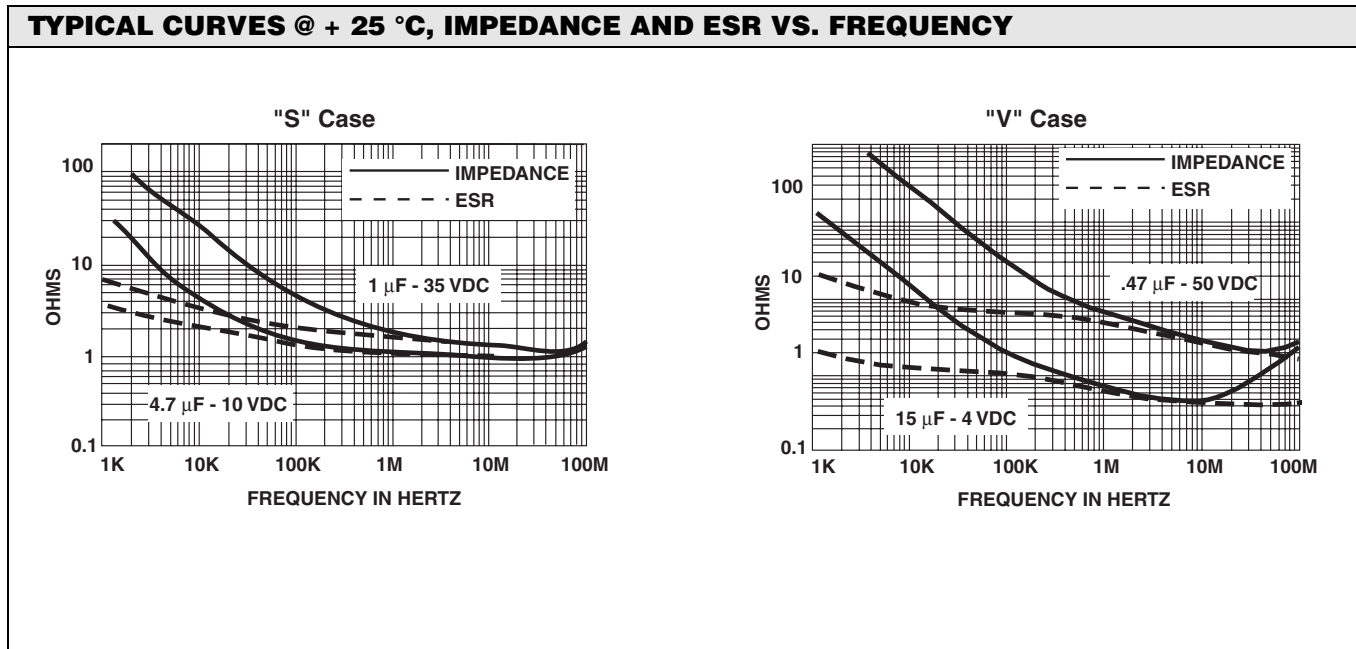



TYPICAL CURVES @ + 25 °C, IMPEDANCE AND ESR VS. FREQUENCY

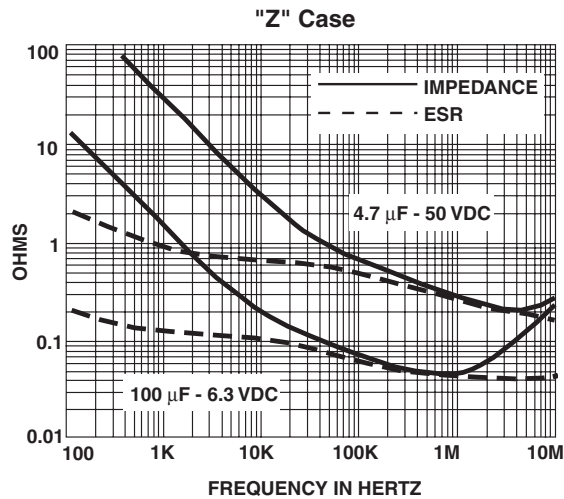
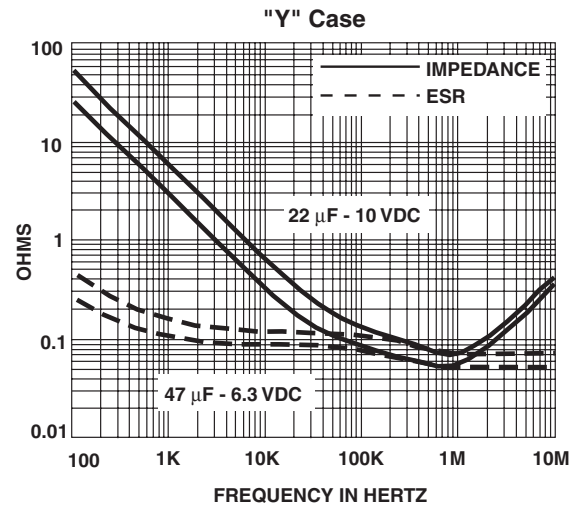
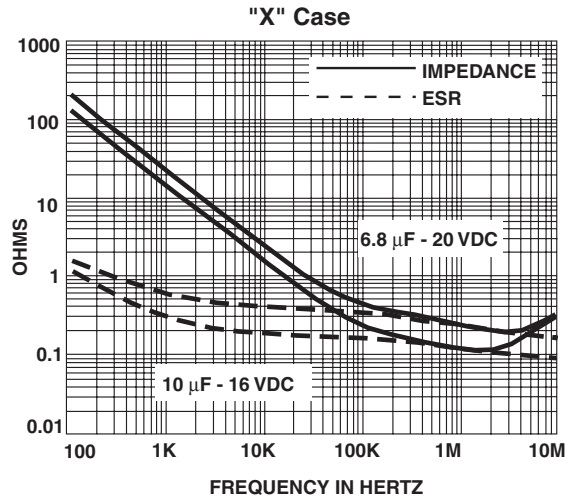

Solid Tantalum Chip Capacitors
TANTAMOUNT® Conformal Coated

ORDERING INFORMATION - EUROPEAN USE ONLY

195D TYPE	106 CAPACITANCE	X0 CAPACITANCE TOLERANCE	004 DC VOLTAGE RATING AT + 85 °C	D CASE CODE	2 TERMINATION	T PACKAGING
	This is expressed in picofarads. The first two digits are the significant figures. The third is the number of zeros to follow.	X0 = ± 20 % X9 = ± 10 %	This is expressed in volts. To complete the three-digit block, zeros precede the voltage rating. A decimal point is indicated by an "R" (6R3 = 6.3 volts).	See Ratings and Case Codes Table.	Style 2 is standard 2 = Solderable Coating 4 = Gold Plated 8 = Solder Plated (60/40) Special Order	T = Tape and Reel 180 mm Reel standard E = Tape and Reel 180 mm Reel for H case size, lengthwise. See Tape and Reel Specifications.

Note: Preferred Tolerance and reel sizes are in bold. We reserve the right to supply higher voltage ratings and tighter capacitance tolerance capacitors in the same case size. Voltage substitutions will be marked with the higher voltage rating.

DIMENSIONS in millimeters

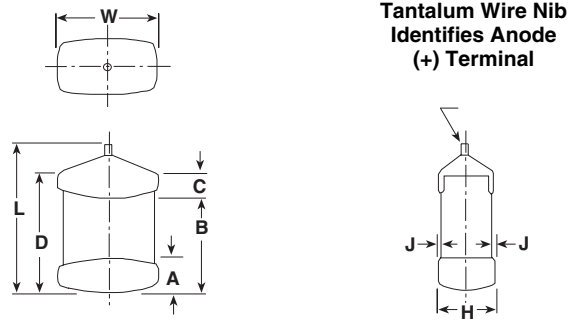

CASE CODE	L ± 0.3	W ± 0.3	H (max)	A ± 0.3	B ± 0.3	C (min)
A	2.8*	1.5	1.4	0.7	1.6	0.3
B	4.2*	1.4	1.6	0.8	2.5	0.3
D	4.2*	2.1	1.6	0.8	2.5	0.5
E	5.5	2.1	1.7	1.0	3.2	0.8
F	5.0	3.3	2.0	1.0	3.6	0.8
G	7.0	2.6	2.8	1.0	4.5	0.8
H	7.8	3.7	3.0	1.0	5.0	0.8

* ± 0.2

Note: The anode termination (D less B) will be a minimum of 0.010 (0.25), C Case = 0.005 (0.131) minimum



195D / CTC2 STANDARD RANGE, RATINGS AND CASE CODES									
µF	2V	4 V	6.3 V	10 V	15 / 16 V	20 V	25 V	35 /40 V	50 V
0.10								A	A
0.15								A	A
0.22								A	B
0.33							A	B	B
0.47					A	A		B	D
0.68					A		B	D	D
1.0				A	B	B		D	E
1.5			A		B		D	E	F
2.2		A		B		D	E	F	F
3.3	A		B		D	E		F	G
4.7	A	B		D	E		F	G	H
6.8	A		D	E		F	G	H	
10	A	D	E		F		G		
15		E		F		G	H		
22			F		G	H			
33		F		G	H				
47			G	H					
68		G	H						
100		H							

*Note: 2, 15, 20 and 35 Volt are not CTC2 ratings

STANDARD RATINGS					
CAPACITANCE (µF)	CASE CODE	PART NUMBER	Max. DCL at + 25 °C (µA)	Max. DF at + 25 °C 120 Hz (%)	
2 WVDC @ + 85 °C, SURGE = 2.6 V . . . 1.2 WVDC @ + 125 °C, SURGE = 1.6 V					
3.3	A	195D335X_002A2T	0.5	8	
4.7	A	195D475X_002A2T	0.5	8	
6.8	A	195D685X_002A2T	0.5	8	
10	A	195D106X_002A2T	0.6	8	
4 WVDC @ + 85 °C, SURGE = 5 V . . . 2.7 WVDC @ + 125 °C, SURGE = 3.4 V					
2.2	A	195D225X_004A2T	0.5	8	
4.7	B	195D475X_004B2T	0.5	8	
10	D	195D106X_004D2T	0.5	8	
15	E	195D156X_004E2T	0.6	8	
33	F	195D336X_004F2T	1.3	8	
68	G	195D686X_004G2T	2.7	8	
100	H	195D107X_004H2E	4.0	8	
6.3 WVDC @ + 85 °C, SURGE = 8 V . . . 4 WVDC @ + 125 °C, SURGE = 5 V					
1.5	A	195D155X_6R3A2T	0.5	8	
3.3	B	195D335X_6R3B2T	0.5	8	
6.8	D	195D685X_6R3D2T	0.5	8	
10	E	195D106X_6R3E2T	0.6	8	
22	F	195D226X_6R3F2T	1.3	8	
47	G	195D476X_6R3G2T	2.8	8	
68	H	195D686X_6R3H2E	4.1	8	

For 10 % tolerance, specify "9"; for 20 % tolerance, change to "0".

STANDARD RATINGS				
CAPACITANCE (μF)	CASE CODE	PART NUMBER	Max. DCL at + 25 °C (μA)	Max. DF at + 25 °C 120 Hz (%)
10 WVDC @ + 85 °C, SURGE = 13 V . . . 7 WVDC @ + 125 °C, SURGE = 9 V				
1.0	A	195D105X_010A2T	0.5	6
2.2	B	195D225X_010B2T	0.5	6
4.7	D	195D475X_010D2T	0.5	6
6.8	E	195D685X_010E2T	0.7	6
15	F	195D156X_010F2T	1.5	6
33	G	195D336X_010G2T	3.3	6
47	H	195D476X_010H2E	4.7	6
15 / 16 WVDC @ + 85 °C, SURGE = 20 V...10 WVDC @ + 125 °C, SURGE = 12 V				
0.47	A	195D474X_015A2T	0.5	6
0.68	A	195D684X_015A2T	0.5	6
1.0	B	195D105X_015B2T	0.5	6
1.5	B	195D155X_015B2T	0.5	6
3.3	D	195D335X_015D2T	0.5	6
4.7	E	195D475X_015E2T	0.7	6
10	F	195D106X_015F2T	1.5	6
22	G	195D226X_015G2T	3.3	6
33	H	195D336X_015H2E	5.0	6
20 WVDC @ + 85 °C, SURGE = 26 V . . . 13 WVDC @ + 125 °C, SURGE = 16 V				
0.47	A	195D474X_020A2T	0.5	6
1.0	B	195D105X_020B2T	0.5	6
2.2	D	195D225X_020D2T	0.5	6
3.3	E	195D335X_020E2T	0.7	6
6.8	F	195D685X_020F2T	1.4	6
15	G	195D156X_020G2T	3.0	6
22	H	195D226X_020H2E	4.4	6
25 WVDC @ + 85 °C, SURGE = 32 V . . . 17 WVDC @ + 125 °C, SURGE = 20 V				
0.33	A	195D334X_025A2T	0.5	6
0.68	B	195D684X_025B2T	0.5	6
1.5	D	195D155X_025D2T	0.5	6
2.2	E	195D225X_025E2T	0.6	6
4.7	F	195D475X_025F2T	1.2	6
6.8	G	195D685X_025G2T	1.7	6
10	G	195D106X_025G2T	2.5	6
15	H	195D156X_025H2E	3.8	6

For 10 % tolerance, specify "9"; for 20 % tolerance, change to "0".



STANDARD RATINGS				
CAPACITANCE (μF)	CASE CODE	PART NUMBER	Max. DCL at + 25 °C (μA)	Max. DF at + 25 °C 120 Hz (%)
35 / 40 WVDC @ + 85 °C, SURGE = 46 / 52 V . . . 23 / 25 WVDC @ + 125 °C, SURGE = 28 / 30 V				
0.10	A	195D104X_035A2T	0.5	6
0.15	A	195D154X_035A2T	0.5	6
0.22	A	195D224X_035A2T	0.5	6
0.33	B	195D334X_035B2T	0.5	6
0.47	B	195D474X_035B2T	0.5	6
0.68	D	195D684X_035D2T	0.5	6
1.0	D	195D105X_035D2T	0.5	6
1.5	E	195D155X_035E2T	0.5	6
2.2	F	195D225X_035F2T	0.8	6
3.3	F	195D335X_035F2T	1.2	6
4.7	G	195D475X_035G2T	1.6	6
6.8	H	195D685X_035H2E	2.4	6
50 WVDC @ + 85 °C, SURGE = 65 V . . . 33 WVDC @ + 125 °C, SURGE = 38 V				
0.10	A	195D104X_050A2T	0.5	6
0.15	A	195D154X_050A2T	0.5	6
0.22	B	195D224X_050B2T	0.5	6
0.33	B	195D334X_050B2T	0.5	6
0.47	D	195D474X_050D2T	0.5	6
0.68	D	195D684X_050D2T	0.5	6
1.0	E	195D105X_050E2T	0.5	6
1.5	F	195D155X_050F2T	0.8	6
2.2	F	195D225X_050F2T	1.1	6
3.3	G	195D335X_050G2T	1.7	6
4.7	H	195D475X_050H2E	2.4	6

For 10 % tolerance, specify "9": for 20 % tolerance, change to "0".

Solid Tantalum Chip Capacitors
TANTAMOUNT® Conformal Coated

PERFORMANCE CHARACTERISTICS

European Product Case sizes A to H comply to:
CECC 30801/006/008 - CTC2

1. **Operating Temperature:** Capacitors are designed to operate over the temperature range of - 55 °C to + 85 °C.
 - 1.1 Capacitors may be operated to + 125 °C with voltage derating to two-thirds the + 85 °C rating.

+ 85 °C RATING		+ 125 °C RATING	
Working Voltage (V)	Surge Voltage (V)	Working Voltage (V)	Surge Voltage (V)
2.0	2.6	1.2	1.6
4.0	5.0	2.7	3.4
6.3	8.0	4.0	5.0
10	13	7.0	9.0
15/16	20	10	12
20	26	13	16
25	32	17	20
35	46	23	28
40	52	25	30
50	65	33	38

2. **DC Working Voltage:** The DC working voltage is the maximum operating voltage for continuous duty at the rated temperature.
3. **Surge Voltage:** The surge DC rating is the maximum voltage to which the capacitors may be subjected under any conditions, including transients and peak ripple at the highest line voltage.
 - 3.1 **Surge Voltage Test:** Capacitors rated up to 35 volts at + 85 °C shall withstand the surge voltage applied in series with a 33 ohm \pm 5 % resistor at the rate of one-half minute on, one-half minute off, at + 85 °C, for 1000 successive test cycles. Capacitors rated 50 volts at + 85 °C require a series resistance of 1000 ohms.
 - 3.2 Following the surge voltage test, the dissipation factor and the leakage current shall meet the initial requirements; the capacitance shall not have changed more than \pm 5 %.
4. **Capacitance Tolerance:** The capacitance of all capacitors shall be within the specified tolerance limits of the nominal rating.
 - 4.1 Capacitance measurements shall be made by means of polarized capacitance bridge. The polarizing voltage shall be of such magnitude that there shall be no reversal of polarity due to the AC component. The maximum voltage applied to capacitors during measurement shall be 2 volts rms at 120 Hz at + 25 °C. If the AC voltage applied is less than one-half

volt rms, no DC bias is required. Accuracy of the bridge shall be within \pm 2 %.

5. **Capacitance Change With Temperature:** The capacitance change with temperature shall not exceed the following percentage of the capacitance measured at + 25 °C:

- 55 °C	+85 °C	+ 125 °C
- 10 %	+ 10 %	+ 12 %

6. **Dissipation Factor:** The dissipation factor, determined from the expression $2\pi fRC$, shall not exceed values listed in the Standard Ratings Table.
 - 6.1 Measurements shall be made by the bridge method at, or referred to, a frequency of 120 Hz and a temperature of + 25 °C.
7. **Leakage Current:** Capacitors shall be stabilized at the rated temperature for 30 minutes. Rated voltage shall be applied to capacitors for 5 minutes using a steady source of power (such as a regulated power supply) with a 1000 ohm resistor connected in series with the capacitor under test to limit the charging current. Leakage current shall then be measured. *Note that the leakage current varies with temperature and applied voltage. See graph below for the appropriate adjustment factor.*

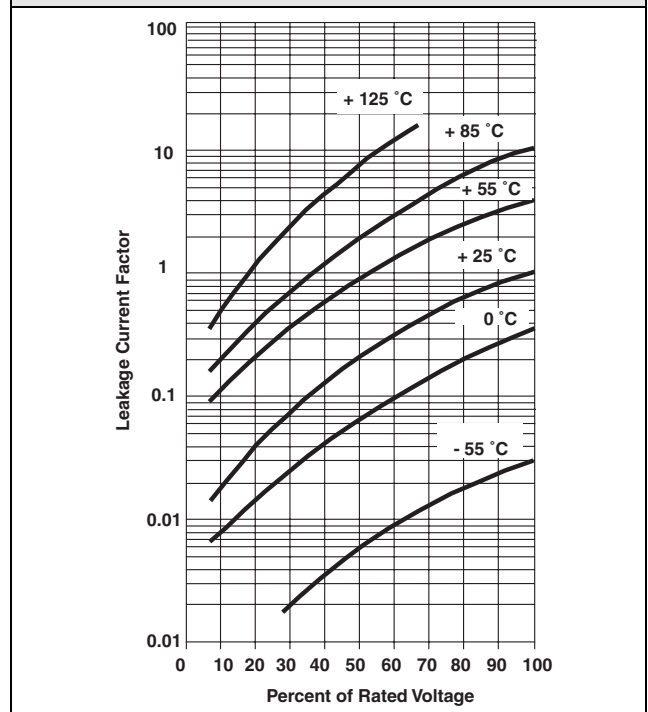
TYPICAL LEAKAGE CURRENT FACTOR RANGE



PERFORMANCE CHARACTERISTICS (Continued)

- 7.1 **At + 25 °C**, the leakage current shall not exceed the value listed in the Standard Ratings Table.
- 7.2 **At + 85 °C**, the leakage current shall not exceed 10 times the value listed in the Standard Ratings Table.
- 7.3 **At + 125 °C**, the leakage current shall not exceed 12 times the value listed in the Standard Ratings Table.
- 8. **Life Test:** Capacitors shall withstand rated DC voltage applied at + 85 °C or two-thirds rated voltage applied at + 125 °C for 2000 hours.
- 8.1 Following the life test, the dissipation factor and leakage current shall meet the initial requirement; the capacitance change shall not exceed ± 10 %.
- 9. **Shelf Life:** Capacitors shall withstand a shelf test for 5000 hours at a temperature of + 85 °C with no voltage applied.
- 9.1 Following the shelf life test, the leakage current shall meet the initial requirement; the dissipation factor shall not exceed 150 % of the initial requirement; the capacitance change shall not exceed ± 5 %
- 10 **Moisture Resistance:**
- 10.1 Capacitors shall be subjected to temperature cycling at 90 % to 95 % relative humidity, from + 25 °C to + 65 °C to + 25 °C (+ 10 °C, - 2 °C) over a period of 8 hours per cycle for 1000 hours.
- 10.2 Following the moisture resistance test, the leakage current and dissipation factor shall meet the initial requirements, and the change in capacitance shall not exceed ± 10 %.
- 11. **Humidity Test:**
- 11.1 Capacitors shall withstand exposure to 90 % to 95 % relative humidity at full rated voltage at + 40 °C for 1000 hours.
- 11.2 Following the humidity test, the leakage current shall not exceed 200 % of the initial requirement; the dissipation factor shall not exceed 150 % of the initial requirement; the change in capacitance shall not exceed ± 12 %
- 12. **Thermal Shock:**
- 12.1 Capacitors shall be conditioned prior to temperature cycling for 15 minutes at + 25 °C, at less than 50 % relative humidity and a barometric pressure at 28 to 31 inches.
- 12.2 Capacitors shall be subjected to thermal shock in a cycle of exposure to ambient air at - 55 °C (+ 0 °C, - 5 °C) for 30 minutes, then + 25 °C (+10 °C, - 5 °C) for 5 minutes, then + 125 °C (+ 3 °C, - 0 °C) for 30 minutes, then + 25 °C (+ 10 °C, - 5 °C) for 5 minutes for 5 cycles.
- 12.3 Capacitors shall show no evidence of harmful or extensive corrosion, obliteration of marking or other visible damage.
- 12.4 Following the thermal shock test, capacitors shall meet the original requirements for leakage current and dissipation factor, capacitance change shall not exceed ± 5 % of the original measured value.
- 13. **Soldering Compatibility:**
- 13.1 **Solder Dip:** Capacitors will withstand two cycles of a dip in non-activated rosin flux, followed by full immersion in lead (Pb)- free solder for 5 seconds at + 245 °C.
- 13.1.1 **Capacitance:** DC leakage and dissipation factor shall remain within the initial requirements.
- 13.1.2 There shall be no evidence of dewetting or termination leaching. Wetting must occur on at least 95 % of the metallized surface (per MIL-C-55365).
- 13.2 **Solder Heat:** Capacitors will withstand exposure to + 245 °C + 5 °C for 10 seconds.
- 13.3 **Solderability:** Capacitors will meet the solderability requirements of (MIL-C-55365)
- 14. **Marking:** The small body area of these capacitors does not permit elaborate marking schemes. Required information will be distinctly marked on the carton or packages in which the units are shipped.
- 15. **Polarity:** The anode terminal of each capacitor is identified by wire nib (see dimensional configurations).

GUIDE TO APPLICATION

- 1. **Recommended voltage derating guidelines:**
(-55 °C to + 85 °C)

Standard Conditions, for example; output filters

Capacitor Voltage Rating (V)	Operating Voltage (V)
4.0	2.5
6.3	3.6
10	6.0
16	10
20	12
25	15
35	24
50	28

Severe Conditions, for example; input filters

Capacitor Voltage Rating (V)	Operating Voltage (V)
4.0	2.5
6.3	3.3
10	5.0
16	8.0
20	10
25	12
35	15
50	24

**GUIDE TO APPLICATION** (Continued)

2. **A-C Ripple Current:** The maximum allowable ripple current shall be determined from the formula:

$$I_{rms} = \sqrt{\frac{P}{R_{ESR}}}$$

where,

P = Power Dissipation in Watts at + 25 °C as given in the table in Paragraph Number 6 (Power Dissipation)

R_{ESR} = The capacitor Equivalent Series Resistance at the specified frequency.

- 2.1 Non-sinusoidal ripple current may produce heating effects that differ from those produced by sinusoidal ripple current. It is important that the I_{rms} value be established when calculating permitted operating levels.

- 2.2 Permissible power dissipation as shown in Paragraph Number 6 (Power Dissipation) has been determined for a maximum chip temperature rise of 25°C above ambient temperature (T_A) with the chip supported in air by lead attachments.

Because the effectiveness of heat sinking varies widely with ambient conditions and thermal management, criteria may be unnecessarily conservative. It is recommended that thermocouple measurements of actual chip temperature be made under operating condition. In no case should the chip temperature rise above + 85 °C at rated voltage.

3. **A-C Ripple Voltage:** The maximum allowable ripple voltage shall be determined from the formula:

$$V_{rms} = Z \sqrt{\frac{P}{R_{ESR}}}$$

or, from the formula:

$$V_{rms} = I_{rms} \times Z$$

where,

P = Power Dissipation in Watts at + 25 °C as given in the table in Paragraph Number 6 (Power Dissipation).

R_{ESR} = The capacitor Equivalent Series Resistance at the specified frequency.

Z = The capacitor impedance at the specified frequency.

- 3.1 The sum of the peak AC voltage plus the applied DC voltage shall not exceed the DC voltage rating of the capacitor.

- 3.2 The sum of the negative peak AC voltage plus the applied DC voltage shall not allow a voltage reversal exceeding 15 % of the DC working voltage at + 25 °C.

4. **Reverse Voltage:** These capacitors are capable of withstanding peak voltages in the reverse direction equal to 15 % of the DC rating at + 25 °C and 5 % of the DC rating at + 85 °C.

5. **Temperature Derating:** If these capacitors are to be operated at temperatures above + 25 °C, the permissible rms ripple current or voltage shall be calculated using the derating factors as shown:

Temperature	Derating Factor
+ 25 °C	1.0
+ 55 °C	0.9
+ 85 °C	0.8
+ 125 °C	0.4

6. **Power Dissipation:** Power dissipation will be affected by the heat sinking capability of the mounting surface. Non-sinusoidal ripple current may produce heating effects which differ from those shown. It is important that the equivalent I_{rms} value be established when calculating permissible operating levels.

Case Code	Maximum Permissible Power Dissipation at + 25 °C (watts) in Free Air
C	0.030
R	0.250
S	0.080
V	0.095
X	0.110
Y	0.120
Z	0.135

Case Code	Maximum Permissible Power Dissipation at + 25 °C (watts) in Free Air
A	0.04
B	0.05
D	0.08
E	0.09
F	0.11
G	0.12
H	0.14

7. **Printed Circuit Board Materials:** The capacitors are compatible with most commonly used printed circuit board materials (alumina substrates, FR4, FR5, G10, PTFE-fluorocarbon and porcelainized steel). If your desired board material is not shown there please contact the Tantalum Marketing Department for assistance in determining compatibility.

GUIDE TO APPLICATION (Continued)

8. **Attachment:**

8.1 **Solder Paste:** The recommended thickness of the solder paste after application is 0.007" ± 0.001" [0.178 mm ± 0.025 mm]. Care should be exercised in selecting the solder paste. The metal purity should be as high as practical. The flux (in the paste) must be active enough to remove the oxides formed on the metallization prior to the exposure to soldering heat.

8.2 **Soldering:** Capacitors can be attached by conventional soldering techniques, convection, infrared reflow, wave soldering and hot plate methods. The Soldering Profile chart shows typical recommended time/temperature conditions for soldering. Preheating is recommended to reduce thermal stress. The recommended maximum preheat rate is 2 °C per second. Attachment with a soldering iron is not recommended due to the difficulty of controlling temperature and time at temperature. The soldering iron must never come in contact with the capacitor.

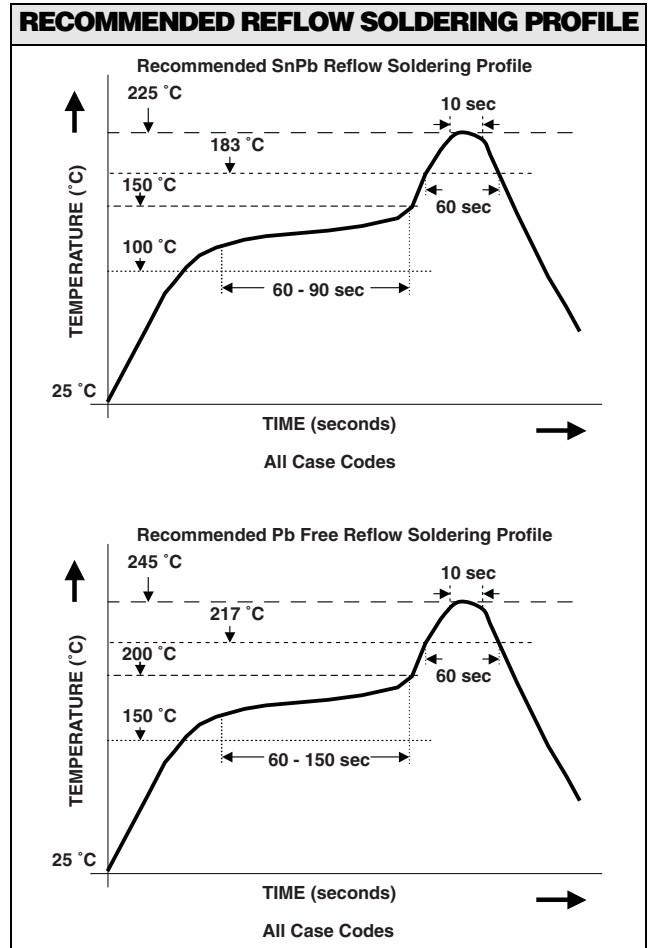

- 8.3 **Conductive Epoxy:** It is recommended that the epoxy cure cycle shall not exceed + 150 °C for sixty minutes.
9. **Cleaning (Flux Removal) after Soldering :** The 195D is compatible with all commonly used solvents, such as TES, TMS, Prelate and Chlorethane. Solvents containing methylene chloride or other epoxy solvents should be avoided since these will attack the epoxy encapsulation material.
10. **Recommended Mounting Pad Geometries:** The nib must have sufficient clearance to avoid electrical contact with other components. The width dimension indicated is the same as the maximum width of the capacitor. This is to minimize lateral movement.

METALLIZATION AND SOLDER PASTE				
Dark areas indicate solder paste				
in inches [millimeters]				
CASE CODE	PAD METALIZATION A	SEPARATION B	ANODE NIB ALLOWANCE C	WIDTH D
C	0.025 [.635]	0.140 [3.55]	0.025 [.635]	0.055 [1.40]
R	0.065 [1.65]	0.113 [2.87]	0.042 [1.07]	0.245 [6.22]
S	0.040 [1.02]	0.040 [1.02]	0.015 [.381]	0.080 [2.03]
V	0.040 [1.02]	0.040 [1.02]	0.015 [.381]	0.114 [2.90]
X	0.065 [1.65]	0.113 [2.87]	0.042 [1.07]	0.114 [2.90]
Y	0.065 [1.65]	0.113 [2.87]	0.042 [1.07]	0.114 [2.90]
Z	0.065 [1.65]	0.113 [2.87]	0.042 [1.07]	0.114 [2.90]

METALLIZATION AND SOLDER PASTE				
Dark areas indicate solder paste				
in millimeters				
CASE CODE	PAD METALIZATION A	SEPARATION B	ANODE NIB ALLOWANCE C	WIDTH D
A	1.1	0.6	0.3	1.7
B	1.2	1.2	0.8	1.6
D	1.4	1.2	0.8	2.3
E	1.4	1.8	1.1	2.3
F	1.4	2.2	1.2	3.5
G	1.4	3.2	1.2	2.8
H	1.4	3.6	1.6	3.9

TAPE AND REEL PACKAGING in inches [millimeters]

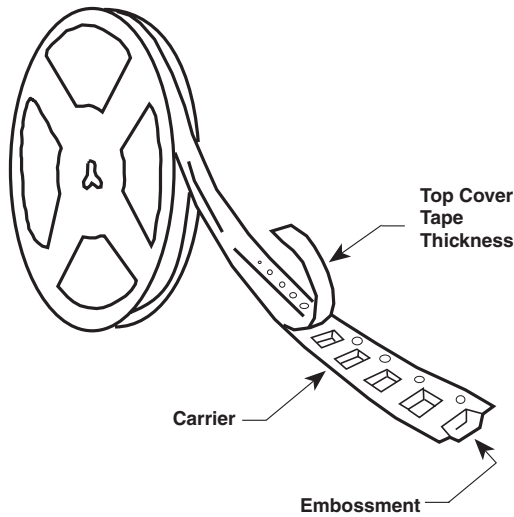

Standard orientation is with the cathode (-) nearest to the sprocket holes per EAI-481-1 and IEC 286-3.

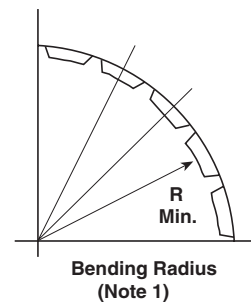

Notes:

- 12 mm embossed tape with components shall pass around radius "R" without damage. The minimum trailer length may require additional length to provide R minimum for reels with hub diameters approaching N minimum.
- For X, Y, Z cases, 4 mm pitch; for R case, 8 mm pitch.

R Minimum:

- 8 mm 1/2 Pitch and 8 mm = 0.984" [25]
- 12 mm, 12 mm Double Pitch = 1.181" [30].

Case Code	Tape Width	Component Pitch	Units Per Reel	
			7" [178] Reel	13" [330] Reel
C	8 mm	4 mm	2500	10000
R	12 mm	8 mm	600	-
S	8 mm	4 mm	2500	10000
V	8 mm	4 mm	2500	10000
X	12 mm	4 mm	2000	10000
Y	12 mm	4 mm	1500	7500
Z	12 mm	4 mm	1500	5000

Case Code	Tape Width	Component Pitch	Units Per Reel	
			180 mm Reel	Taping Code
A	8 mm	4 mm	2500	T
B	12 mm	8 mm	2000	T
D	12 mm	4 mm	2000	T
E	12 mm	4 mm	2000	T
F	12 mm	8 mm	700	T
G	12 mm	4 mm	1400	T
H	12 mm	12 mm	600	T*

* Not available for other case sizes

Solid Tantalum Chip Capacitors
TANTAMOUNT® Conformal Coated

TAPE AND REEL PACKAGING in inches [millimeters]

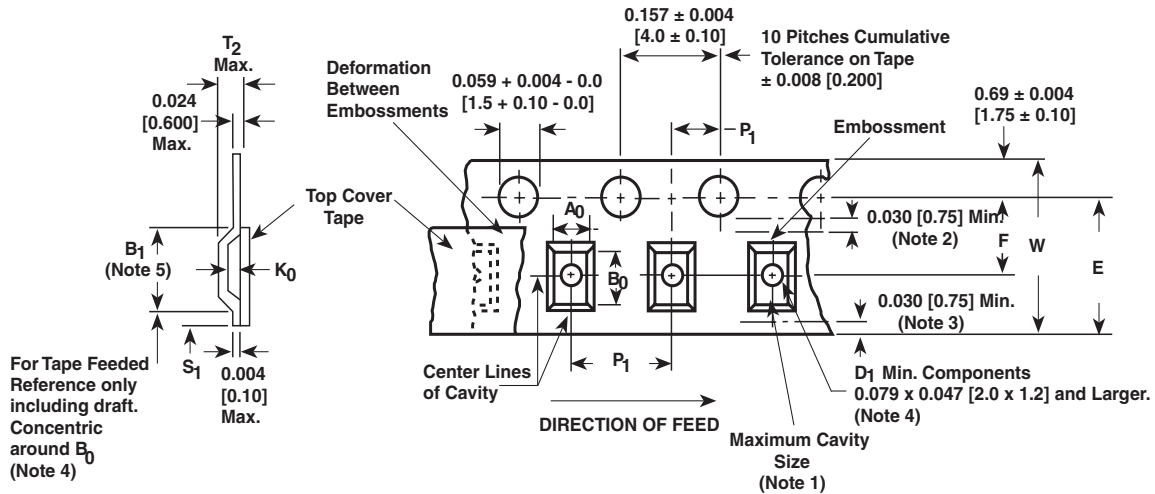

For Tape Fedded Reference only including draft. Concentric around B₀ (Note 4)

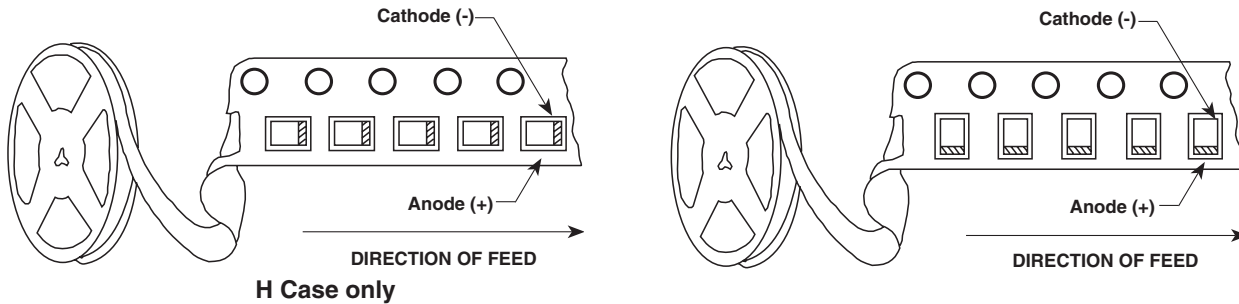

Note: Metric dimensions will govern. Dimensions in inches are rounded and for reference only.

TAPE SIZE	B ₁ (Max.) (Note 5)	D ₁ (Min.) (Note 4)	E (Min.)	F	P ₁	P ₂	S ₁ (Min.)	T ₂ (Max.)	W	A ₀ B ₀ K ₀
8 mm	0.179 [4.55]	0.039 [1.0]	-	0.138 ± 0.002 [3.5 ± 0.05]	0.157 ± 0.004 [4.0 ± 0.10]	0.079 ± 0.002 [2.0 ± 0.05]	-	0.098 [2.5]	0.315 + 0.012 - 0.004 [8.0 + 0.3 - 0.1]	(Note 1)
12 mm	0.323 [8.2]	0.059 [1.5]	-	0.217 ± 0.002 [5.5 ± 0.05]	0.157 ± 0.004 [4.0 ± 0.10]	0.079 ± 0.002 [2.0 ± 0.05]	-	0.256 [6.5]	0.472 ± 0.012 [12.0 ± 0.30]	
12 mm Double Pitch	0.323 [8.2]	0.059 [1.5]	-	0.217 ± 0.002 [5.5 ± 0.05]	0.315 ± 0.004 [8.0 ± 0.10]	0.079 ± 0.002 [2.0 ± 0.05]	-	0.256 [6.5]	0.472 ± 0.012 [12.0 ± 0.30]	

Notes:

- A₀B₀K₀ are determined by the maximum dimensions to the ends of the terminals extending from the component body and/or the body dimensions of the component. The clearance between the ends of the terminals or body of the component to the sides and depth of the cavity (A₀B₀K₀) must be within 0.002" [0.05 mm] minimum and 0.020" [0.50 mm] maximum. The clearance allowed must also prevent rotation of the component within the cavity of not more than 20 degrees.
- This dimension is the flat area from the edge of the sprocket hole to either the outward deformation of the carrier tape between the embossed cavities or to the edge of the cavity whichever is less.
- This dimension is the flat area from the edge of the carrier tape opposite the sprocket holes to either the outward deformation of the carrier tape between the embossed cavity or to the edge of the cavity whichever is less.
- The embossment hole location shall be measured from the sprocket hole controlling the location of the embossment. Dimensions of embossment location and hole location shall be applied independent of each other.
- B₁ dimension is a reference dimension for tape feeder clearance only.